

RF-301A SSB Transceiver

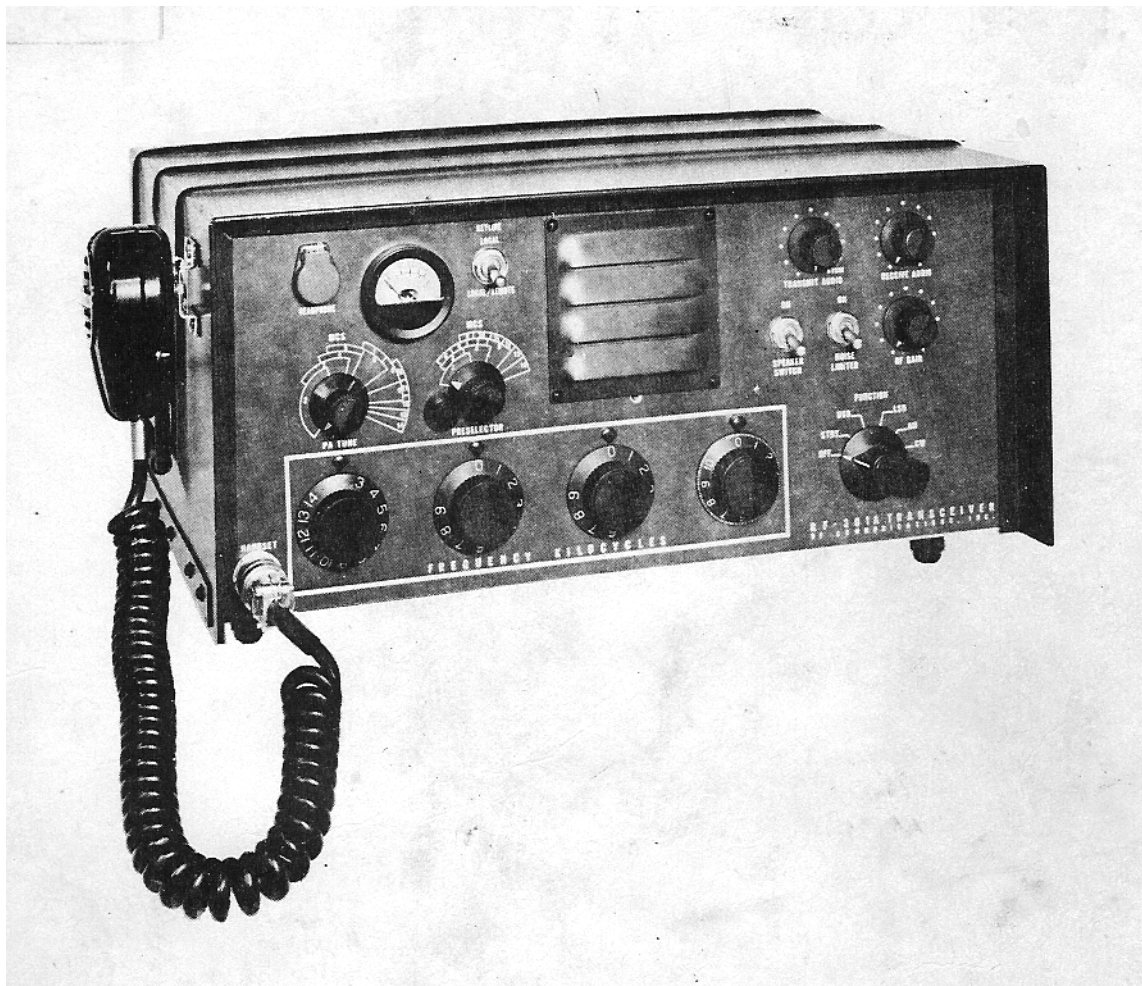

Instruction Manual/PM-0348H



RF COMMUNICATIONS, INC.
1680 UNIVERSITY AVENUE
ROCHESTER, NEW YORK, 14610, U.S.A.

INSTRUCTION MANUAL ADDENDUM

ADDENDUM No. PM-1246
 APPLICABLE SDN No.(S)
 APPLICABLE DCN No.(S)

APPLICABLE TO: RF-301/A

Revised 4/8-76 (V. Mussard)

The attached parts lists and circuit diagrams of the 162-1100 and 162-1200 assemblies show the correct circuitry and parts. Delete the corresponding parts lists and circuit diagrams in instruction manual PM-0301H or PM-0348H.



RF COMMUNICATIONS, INC.
1680 UNIVERSITY AVENUE
ROCHESTER, NEW YORK, 14610, U.S.A.

INSTRUCTION MANUAL ADDENDUM

ADDENDUM No. PM-1238
 APPLICABLE SDN No.(S) 162-11,-12,-13
 APPLICABLE DCN No.(S)

APPLICABLE TO: RF-301/A

Make the following changes to your RF-301 or RF-301A Instruction Manual, PM-0301G or PM-0348G.

Page 7-1, Main Frame Parts List

Add Capacitor, Durez; .01 uF; 50 Vdcw RF P/N C-4952

Change Diodes CR13, CR14, CR15 and CR16 to type ~~1N4140~~ RF P/N CR-0072

1N4140

Revised 1/6-76

Revised

Page 7-7 Translator Assembly Parts List

Change R19 to 5.6 K RF P/N R-1267

Revised 1/6-76 PC

Page 8-11/8-12 figure 8.10 Translator Assembly Circuit Diagram

Change R19 to 5.6 K

Revised 1/6-76

Page 8-33/8-34 figure 8.31 Main Frame Circuit Diagram

Change CR13, CR14, CR15 and CR16 to type 1N4140. Show an added .01 uF capacitor connected from pin 14 of K4 (T/R relay) to ground.

Revised 1/6-76



RF COMMUNICATIONS, INC.
1680 UNIVERSITY AVENUE
ROCHESTER, NEW YORK, 14610, U.S.A.

INSTRUCTION MANUAL ADDENDUM

ADDENDUM No. PM-1237

APPLICABLE SDN No.(S) 162-10

APPLICABLE DCN No.(S)

APPLICABLE TO: RF-301/A
Main Frame

relet 4/8-76 O. Musdal

Make the following change to your RF-301 or RF-301A Instruction Manual,
PM-0301G or PM-0348G.

✓ Page 7-1 Main Frame Parts List

Add: Capacitor, Ceramic; 0.01 uF; 1000 Vdcw RF P/N C-5000

✓ Page 8-33/8-34, figure 8.31, Main Frame Circuit Diagram

Show the added 0.01 capacitor connected across terminals of C1.



RF COMMUNICATIONS, INC.
1680 UNIVERSITY AVENUE
ROCHESTER, NEW YORK, 14610, U.S.A.

INSTRUCTION MANUAL ADDENDUM

ADDENDUM No. PM-1236

APPLICABLE SDN No.(S) 162-8

APPLICABLE DCN No.(S)

APPLICABLE TO: RF-301/A
162-1600 ACC Assembly

relet 4/8-76 O. Musdal

Make the following changes to your RF-301 or RF-301A Instruction Manual,
PM-0301G or PM-0348G.

✓ Page 7-12, ACC Circuit Assembly 162-1600

Delete CR1.

✓ Page 8-29/8-30, figure 8.28

Delete CR1.



RF COMMUNICATIONS, INC.
1680 UNIVERSITY AVENUE
ROCHESTER, NEW YORK, 14610, U.S.A.

INSTRUCTION MANUAL ADDENDUM

ADDENDUM No. PM-1235 A

APPLICABLE SDN No.(S) 162-5,
APPLICABLE DCN No.(S) 162-15

APPLICABLE TO: RF-301/A
162-0600 Translator Assembly

revised 9/8-76 O'Keefe

Make the following changes to your RF-301 or RF-301A Instruction Manual, PM-0301G or PM-0348G, respectively.

✓ Page 7-7, Translator Assembly 162-0600 Parts List

Change Q2 and Q3 to type 2N4916 RF P/N Q-0360
Change R5 and R9 to 1 K RF P/N R-1249
Change R11 and R12 to 220 ohms RF P/N R-1233

✓ Page 8-11/8-12, figure 8.10

Change Q2 and Q3 to type 2N4916.
Change R5 and R9 to 1K.
Change R11 and R12 to 220 ohms.

TABLE OF CONTENTS

SECTION	PAGE	SECTION	PAGE
1	GENERAL INFORMATION		
1.1	Scope	4.6	AGC, ALC, and ACC Automatic Control Circuits
1.2	Functional Description		4-5
1.3	Quick Reference Data	4.7	Circuit Descriptions
1.4	Accessories Available		4-5
1.5	List of Assemblies		
1.6	Reshipping		
2	INSTALLATION	5	MAINTENANCE
2.1	Unpacking and Inspection	5.1	General
2.2	Power Requirements	5.2	Fuse Replacement
2.3	Installation of DC Power Modules	5.3	Visual Inspection
2.4	Power Cable Installation	5.4	Lubrication
2.5	Mounting	5.5	Test Equipment
2.6	Typical Antenna Installations	5.6	Tube Replacement
2.7	Accessory Connections	5.7	PA Bias Adjustment
2.8	Microphone, Headphone, and CW Hand Key Connections	5.8	Performance Tests
		5.9	Power Supply Voltage Measurements
3	OPERATION		5-3
3.1	General Description	6	SERVICING
3.2	Description of Controls, Indicators and Connectors	6.1	General
3.3	Frequency Setting	6.2	Power Supplies
3.4	Preparation For Operation	6.3	Test Equipment Required
3.5	Operation	6.4	Printed Circuit Board Repairs
3.6	Operator Maintenance	6.5	Test Points
4	PRINCIPLES OF OPERATION	6.6	Locating the Faulty Functional Section
4.1	Functional Description	6.7	Locating the Problem Within the Functional Section
4.2	Main Signal Flow	6.8	Power Amplifier (PA) Section
4.3	Frequency Synthesizer	6.9	RF Amplifier
4.4	Power Supplies	6.10	Divider/Spectrum Generator
4.5	T/R Switching	6.11	11.6 MHz Error Mixer
		6.12	455 kHz Error Mixer
		6.13	Translator
		6.14	IF Amplifier
		6.15	Audio/Modulator
		6.16	VFO

TABLE OF CONTENTS (Cont)

SECTION	PAGE	SECTION	PAGE
6.17	Crystal Oscillators	6.23	Receiver Protector
6.18	ALC		
6.19	ACC	7	PARTS LIST
6.20	Audio Amplifier	8	CIRCUIT DIAGRAMS
6.21	DC Power Modules		
6.22	Frequency Standard Alignment Procedures		6-40
			6-40
			7-1
			8-1

LIST OF ILLUSTRATIONS

FIGURE	PAGE	FIGURE	PAGE
1.1	RF-301A Shown with RF-305A Shockmount	4.5	Switching Diodes
1.2	Antenna Coupler RF-302A	4.6	RF-301 Signal Block Diagram
2.1	RF-301 Rear Panel	5.1	Power Supply Voltage Test Points
2.2	DC Power Module Connections	6.1	Assemblies on Right-Hand Side of Chassis
2.3	RF-301 Outline Drawing	6.2	Assemblies on Top of Chassis
2.4	Typical Base Station Installations	6.3	Assemblies on Underside of Chassis
2.5	Dummy Load and Key Switches	6.4	Relay Terminals
2.6	Doublet Antenna Construction Data	6.5	Feedback Detector Test Circuit
2.7	Inverted V Antenna Construction Data	6.6	Variable Capacitors Shown at Maximum Capacitance Settings
2.8	Typical Installation in a Vehicle	6.7	Frequency Standard, Output at P43, Waveform
2.9	Remote Connections	6.8A	Q1, Base Waveform
3.1	Front Panel Operating Controls	6.8B	Q1, Collector Waveform
4.1	RF-301 Simplified Block Diagram, Illustrating Signal Flow	6.9	Q14, Collector Waveform
4.2	Frequency Synthesizer Simplified Block Diagram, Illustrating Error Loop	6.10	Terminal E84 Waveform
4.3	Frequency Synthesizer Block Diagram, Illustrating Signal Flow	6.11	Q3, Collector Waveform
4.4	Power Supply Block Diagram	6.12	Q16, Base Waveform
		6.13	Q17, Emitter Waveform
		6.14	Terminal E87 Waveform
		6.15	Q7, Collector Waveform
		6.16	Q9, Collector Waveform
		6.17	Q18, Emitter Waveform
		6.18	Terminal E89 Waveform

LIST OF ILLUSTRATIONS (Cont)

FIGURE		PAGE	FIGURE	PAGE	
6.19	Q11, Collector Waveform	6-20	8.16	VFO Schematic Diagram	8-17
6.20	Q13, Collector Waveform	6-20	8.17	MHz Oscillator Parts Location	8-19
6.21	Q19, Emitter Waveform	6-20	8.18	MHz Oscillator Schematic Diagram	8-19
6.22	Right Side of R61 Waveform	6-20	8.19	100 kHz Oscillator Parts Location	8-21
6.23	Switching Diodes	6-26	8.20	100 kHz Oscillator Schematic Diagram	8-21
6.24	DC Power Module Waveforms	6-39	8.21	10 kHz Oscillator Parts Location	8-23
8.1	RF Amplifier Parts Location	8-3	8.22	10 kHz Oscillator Schematic Diagram	8-23
8.2	RF Amplifier Schematic Diagram	8-3	8.23	1 kHz Oscillator Parts Location	8-25
8.3	Divider/Spectrum Generator Parts Location	8-5	8.24	1 kHz Oscillator Schematic Diagram	8-25
8.4	Divider/Spectrum Generator Schematic Diagram	8-5	8.25	ALC Parts Location	8-27
8.5	11.6 MHz Error Mixer Parts Location	8-7	8.26	ALC Schematic Diagram	8-27
8.6	11.6 MHz Error Mixer Schematic Diagram	8-7	8.27	ACC Parts List	8-29
8.7	455 kHz Error Mixer Parts Location	8-9	8.28	ACC Schematic Diagram	8-29
8.8	455 kHz Error Mixer Schematic Diagram	8-9	8.29	Audio Amplifier Parts Location	8-31
8.9	Translator Parts Location	8-11	8.30	Audio Amplifier Schematic Diagram	8-31
8.10	Translator Schematic Diagram	8-11	8.31	Main Frame Schematic Diagram	8-33
8.11	IF Amplifier Parts Location	8-13	8.32	RF-303, 13.5 VDC Power Module Schematic Diagram	8-35
8.12	IF Amplifier Schematic Diagram	8-13	8.33	RF-304, 27.5 VDC Power Module Schematic Diagram	8-37
8.13	Audio/Modulator Parts Location	8-15	8.34	Receiver Protector Assembly Parts Location	8-39
8.14	Audio/Modulator Schematic Diagram	8-15	8.35	Receiver Protector Assembly Schematic Diagram	8-39
8.15	VFO Parts Location	8-17	8.36	MK-0009 Microphone Schematic Diagram	8-41



LIST OF TABLES

TABLE	TITLE	PAGE	TABLE	TITLE	PAGE
1.1	RF-301 Technical Data	1-3	6.5	455 kHz Error Mixer Voltage Chart	6-24
1.2	Assembly References	1-3	6.6	Translator Voltage Chart	6-26
2.1	RF-301 Current Drains Under Various Load Conditions	2-2	6.7	IF Amplifier Voltage Chart	6-28
2.2	Handset Plug Connections	2-11	6.8	Audio/Modulator Voltage Chart	6-30
3.1	Front Panel Devices	3-2	6.9	VFO Voltage Chart	6-31
4.1	Crystal Oscillator and Spectrum Frequencies	4-3	6.10	MHz Oscillator Voltage Chart	6-33
5.1	Power Supply Voltage Measurements	5-3	6.11	100 kHz Oscillator Voltage Chart	6-33
6.0	Fault Location Chart	6-4	6.12	10 kHz Oscillator Voltage Chart	6-33
6.1	Main Frame Voltage Chart	6-8	6.13	1 kHz Oscillator Voltage Chart	6-33
6.2	RF Amplifier Voltage and Resistance Chart	6-10	6.15	ALC Voltage Chart	6-37
6.3A	Spectrum Generator Tests	6-17	6.16	ACC Voltage Chart	6-38
6.3B	Divider/Spectrum Generator Voltage Charts	6-20	6.17	Audio Amplifier Voltage Chart	6-38
6.4	11.6 MHz Error Mixer Voltage Chart	6-23	6.18	Receiver Protector Voltage Chart	6-40

SECTION 1

GENERAL INFORMATION

1.1 SCOPE.

This instruction manual describes the installation, operation, and maintenance of the RF-301A SSB Transceiver, the RF-303 and RF-304 DC Power Modules, and the RF-305A Shockmount. The RF-301A SSB Transceiver is hereafter referred to as the RF-301 Transceiver.

Antenna Coupler Model RF-302A is completely described in its own instruction manual. Throughout this text the RF-302A is referred to as the RF-302.

1.2 FUNCTIONAL DESCRIPTION.

The RF-301A is a high quality, variable frequency SSB transceiver capable of transmitting and re-

ceiving LSB, USB, CW, FSK, and AM signals in mobile or fixed installations. The transceiver can operate on any frequency in the 2 to 15 MHz range and provides an output of 100 watts PEP and average. The transceiver has been designed for rugged service and is splashproof when mounted on the RF-305A Shockmount. Compactness, high reliability and moderate power consumption result from maximum use of transistors and other solid state devices. Digital frequency selection with excellent stability is provided by the frequency synthesizer employed in the RF-301A.

1.3 QUICK REFERENCE DATA.

Data describing the electrical and physical characteristics of the RF-301A Transceiver is given in table I-1.



Figure 1.1 – RF-301A Shown on RF-305A Shockmount

1.4 ACCESSORIES AVAILABLE.

The following accessories are available for the RF-301A Transceiver.

RF-302A	Manual Antenna Coupler
RF-302RA	Remote-Controlled Antenna Coupler
RF-303	13.5VDC Mobile Power Supply Module
RF-304	27.5VDC Mobile Power Supply Module
RF-305A	Shockmount Base for RF-301
RF-307A	Remote Audio Control
RF-308	Running Spare Parts Kit
RF-309	Depot Spare Parts Kit
RF-311	Comprehensive Spare Parts Kit
RF-334A	Doublet Antenna Kit
RF-319	CW Hand Key
RF-102	1KW Linear Amplifier
RF-3001	Headset
RF-3002	Headset with Boom Microphone
RF-318	Extension Cable Test Set

NOTE

The RF-301A Transceiver is normally supplied with a push-to-talk microphone; however, a telephone handset (RF-321) can be supplied on special order.

The following antenna kits are available for use with the RF-302A Antenna Coupler:

SB-V9	Vertical 9 foot whip antenna kit
SB-V16	Vertical 16 foot whip antenna kits
SB-V16A	
SB-V16B	
SB-V16C	
SB-V35	Vertical 35 foot whip antenna kits
SB-V35A	
SB-V35B	
SB-V35C	
SB-V35S	

SB-A75/150 75 or 150 foot long-wire antenna kit

1.5 LIST OF ASSEMBLIES.

Table 1.2 is a list of assemblies used in the RF-301 Transceiver and the reference numbers by which they are identified.

1.6 RESHIPPING.

Should it be necessary to reship the RF-301 or any of its accessories after the original packing material is discarded, be sure to pack each unit separately and carefully. Special attention should be given to providing enough packing material around controls and connectors. Rigid cardboard should be placed at the corners of the equipment to protect against denting. Mark the container "FRAGILE-ELECTRONIC EQUIPMENT".



Figure 1.2 — Antenna Coupler RF-302A



Table 1.1 – RF-301 Technical Data

FREQUENCY RANGE 2 to 15 MHz
RESOLUTION Digital – 1 kHz Vernier – continuous tuning
FREQUENCY STABILITY 1 part in 10 ⁶ per month with regular frequency standard. 5 parts in 10 ⁸ per month with high stability frequency standard.
MODES OF OPERATION Upper Sideband (USB) Lower Sideband (LSB) AM (compatible) CW
ANTENNA INPUT-OUTPUT IMPEDANCE 52 ohms (VSWR 1.5 to 1 or better)
POWER OUTPUT SSB – 100 watts PEP CW – 100 watts average AM – 25 watts carrier
CARRIER SUPPRESSION -50 dB nominal
UNDESIRED SIDEBAND SUPPRESSION -50 dB
HARMONIC SUPPRESSION -45 dB nominal
INTERMODULATION DISTORTION -35 dB nominal at rated power output
REMOTE AUDIO INPUT (Balanced 600 ohms) Normally less than +6 dBm for full output
LOCAL AUDIO INPUT (Microphone) Carbon or dynamic microphone
RECEIVER SENSITIVITY (SSB) 1 microvolt for 10 dB(S+N)/N
RECEIVER SENSITIVITY (AM) 3 microvolts/30% MOD for 10 dB(S+N)/N
SELECTIVITY (SSB and CW) 300 to 3200 Hz, 6 dB
SELECTIVITY (AM) 11 kHz bandwidth, nominal
AUDIO OUTPUT (Speaker) 2 watts, undistorted

Table 1.1 – RF-301 Technical Data (Cont.)

IMAGE REJECTION -70 dB
AGC CHARACTERISTICS Fast attack, slow release
POWER CONSUMPTION 115 VAC ±10%/2.9 A 230 VAC ±10%/1.5 A 13.5 VDC nominal ±10%/27 A 27.5 VDC nominal ±10%/13 A
SIZE 15-9/16 in. D x 17-1/6 in. W x 7-5/8 in. H
WEIGHT 59 LBS
ENVIRONMENTAL Temperature – -30 to +65°C at 100 W PEP -30 to +50°C at 100 W average Humidity – 95% and splashproof Shock – Per MIL-STD-202C, Method 205C Vibration – Per MIL-STD-167

Table 1.2 – Assembly References

REFERENCE NUMBER	NOMENCLATURE
G2	RF Amplifier
03	Divider/Spectrum Generator
04	11.6 MHz Error Mixer
05	455 kHz Error Mixer
055	Receiver Protector
06	Translator
07	IF Amplifier
08	Audio/Modulator
09	VFO
10	MHz Oscillator
11	100 kHz Oscillator
12	10 kHz Oscillator
13	1 kHz Oscillator
15	ALC
16	ACC
17	Audio Amplifier
20	Frequency Standard



SECTION 2

INSTALLATION

2.1 UNPACKING AND INSPECTION.

Remove packing material from containers and carefully lift out the transceiver. The microphone, line cord, connectors, tools, and spare fuses are wrapped separately. Be sure not to discard small items with packing material. Check off units on the packing list as they are unpacked. Each unit should be inspected carefully for physical damage. If any damage exists, save packing material and containers to substantiate claim with transportation agency.

If it is known that the transceiver might be re-shipped, save the container and packing material for future use.

2.2 POWER REQUIREMENTS.

CAUTION

Connection of a DC power source to AC power connector J1 or connection of an AC power source to DC power connector J2 will damage both the power cable and connector.

DC OPERATION

Make sure that the DC power cable is connected to DC connector J2 and that power switch S1 is set at DC.

AC OPERATION

Make sure that the appropriate AC power cable, 115 VAC or 230 VAC is connected to AC connector J1 and that power switch S1 is set at the appropriate AC position, either 115 VAC or 230 VAC.

The RF-301 Transceiver may be operated from 115 or 230 volt, 50–60 cycle, single phase AC

power or from 13.5 or 27.5 volt DC power when the appropriate DC Power Module is installed.

When shipped for domestic use the unit is set for 115 VAC operation with a 4 AMP fuse installed in fuseholder XF2 (AC). Connect the supplied 115 VAC line cord to J1.

CAUTION

Do not turn line power switch (S1) with power applied to set.

To change to 230 VAC operation, the fuse in XF2 must be replaced by a 3 AMP fuse and line power switch (S1) must be set at the 230 VAC position. A 230 VAC line cord must be used in place of the 115 VAC line cord.

NOTE

The 115 VAC line cord shipped with the RF-301 can be rewired for 230 VAC operation by removing the black wire from pin 1 of P1, and re-connecting it to pin 3.

When shipped for overseas use, the RF-301 is set for 230 VAC operation with a 3 AMP fuse installed in fuseholder XF2 (AC). Connect the supplied 230 VAC line cord to J1.

The power requirements are indicated by actual current drains listed in table 2.1 for operation on various line voltages and under various operating conditions. Be sure the power system for the transceiver is able to properly supply the necessary current requirements for your installation.

NOTE

The transceiver can be operated on 13.5 or 27.5 volt DC power only if the appropriate DC Power Module has been installed in the transceiver.

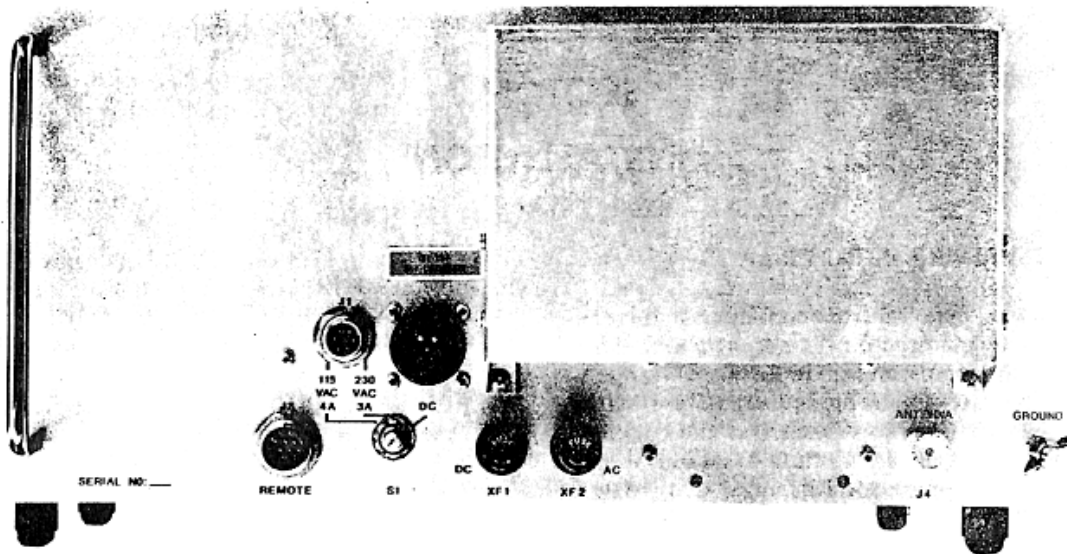

Figure 2.1 – RF-301 Rear Panel

Table 2.1 – RF-301 Current Drains Under Various Load Conditions

LINE VOLT.	STDBY	RECV	XMIT SSB IDLE	XMIT SSB PEAK	XMIT CW OR FSK AVG	XMIT AM AVG
115AC	.5A	.8A	1.3A	2.8A	2.9A	2.3A
230AC	.25A	.4A	.65A	1.4A	1.5A	1.2A
13.5DC	6A	10A	11A	25A	27A	22A
27.5DC	3A	5A	5.5A	12A	13A	10.5A

Separate DC Power Modules are used for 13.5 or 26.0 VDC operation. The RF-303 is used for 13.5 VDC operation, and the RF-304 is used for 26.0 VDC. The line power switch (S1) must be set at the DC position. The AC power cord should be removed from J1, and the DC power cable must be connected to J2.

CAUTION

Under no circumstances should fuses be used with ratings above those specified.

For 13.5 VDC operation, a 25 AMP fuse must be used in the XF1 (DC) fuseholder and for 27.5 VDC, a 15 AMP fuse must be used in XF1.

NOTE

If specified fuses blow repeatedly a technician should check the set and the power source. Frequently power line transients cause fuses to blow. The correct remedy is to install a line regulator. Heavier rated fuses should not be used.

The external DC power source for the DC Power Modules should be voltage regulated with surge variations not exceeding $\pm 10\%$, and have regulation and filtering adequate to prevent combination surge and transient peaks in excess of 30%. Operation with supply variations in excess of these limits can result in damaged components in the converter, or particularly with use of the 13.5



VDC Power Module, damaged components in the transceiver. In the case of mobile or marine installations, where wide variations in engine/generator RPM are normal, proper voltage regulation and transient suppression are extremely important.

CAUTION

The power, microphone, and remote connectors are of the push-on/pull-off type. Do not attempt to twist plugs to remove them.

2.3 INSTALLATION OF DC POWER MODULES.

If supplied for a transceiver already in use, the DC Power Module (either RF-303 or RF-304) must be installed in the set. Remove covers from the transceiver and set it bottom side up with the front panel facing left. The DC Power Module is installed in the open space next to power transformer T1, figure 2.2. Dress the wire leads toward the terminals of T1 and secure the module with the four screws supplied. Two screws are to be installed from the top of the chassis into the module bracket and two through the module bracket into the shield flange on the bottom of the chassis.

2.3.1 RF-303 INSTALLATION.

a. Connect yellow lead of the RF-303 to clip 3 on S1-A, see figure 2.2, and solder.

b. Connect the blue lead of the RF-303 to the top terminal on the vertical terminal strip adjacent to XF-1 and solder.

c. Connect the red lead of the RF-303 to the end terminal of fuseholder XF-1, and solder.

d. Connect a jumper from T1 terminal 7 to the two jumpered terminals with the blue lead, solder both places.

e. Connect the long black lead of the RF-303 to terminal 6 and the short black lead to terminal 8 of T1, solder both places.

2.3.2 RF-304 INSTALLATION.

a. Connect the yellow lead of the RF-304 to clip 3 on S1-A, see figure 2.2, and solder.

b. Connect the black lead of the RF-304 to the top terminal on the vertical terminal strip adjacent to XF-1 and solder.

c. Connect blue lead of the RF-304 to the end terminal of fuseholder XF-1, see figure 2.2.

d. Connect a jumper from end terminal of fuseholder XF-1 to terminal 7 of T1, solder both places.

e. Connect one white lead of the RF-304 to terminal 5 of T1 and the other white lead to terminal 9 of T1, solder both places.

2.4 DC POWER CABLE INSTALLATION.

The appropriate DC Power Cable for use with the DC Power Module installed or to be installed is supplied with the Power Module, complete with connectors. Connect the lug terminated ends of the cable to the batteries, or DC power source to be used, using battery cable connectors or other appropriate hardware; and connect the six terminal connectors on other end of cable to J2 on rear of transceiver. Cable polarity requirements are indicated by tags at the lug ends, rather than by color. The RF-301 can be operated in systems with positive or negative grounds or floating systems (no ground to battery). In all cases the transceiver chassis should be grounded.

2.5 MOUNTING

The transceiver is equipped with rubber feet so that it may be set directly on a table or similar flat surface. The front feet are longer than the rear feet to provide a convenient operating angle. Care is required to prevent blocking the air intake under the case when the transceiver is on an uneven surface. Minimum clearance of 3/4 inch should be allowed on each side, and 2 inches at the rear of the transceiver for cabling.

The RF-305A Shockmount is designed to be used with the transceiver in vehicular installations. An air filter is built into the shockmount directly under the air intake on the transceiver cabinet.

To install the shockmount, set it temporarily on the mounting surface, allowing 2 inch clearance on both sides and 2 inches on back of the transceiver (see figure 2.3). Mark the position of the mounting

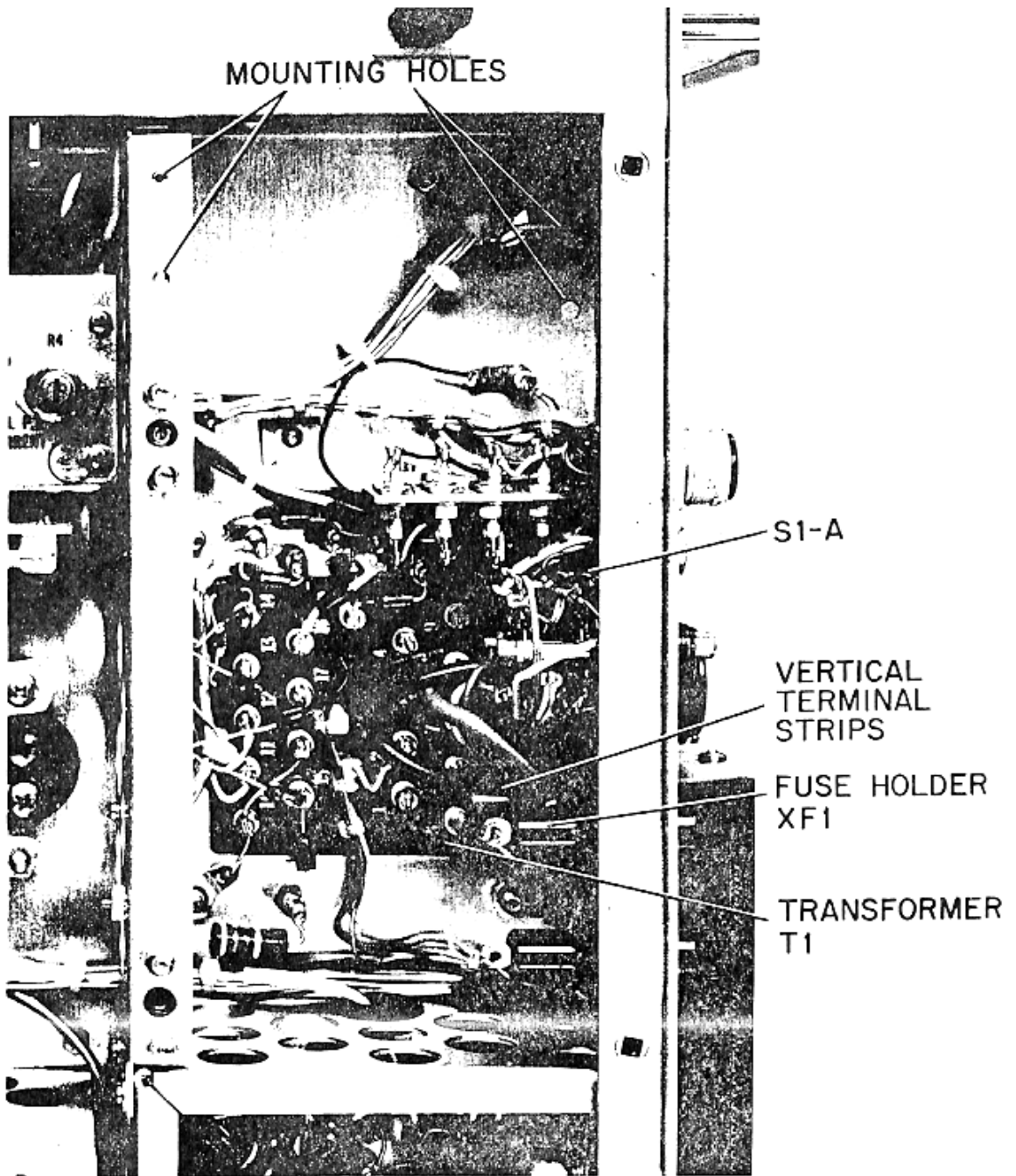
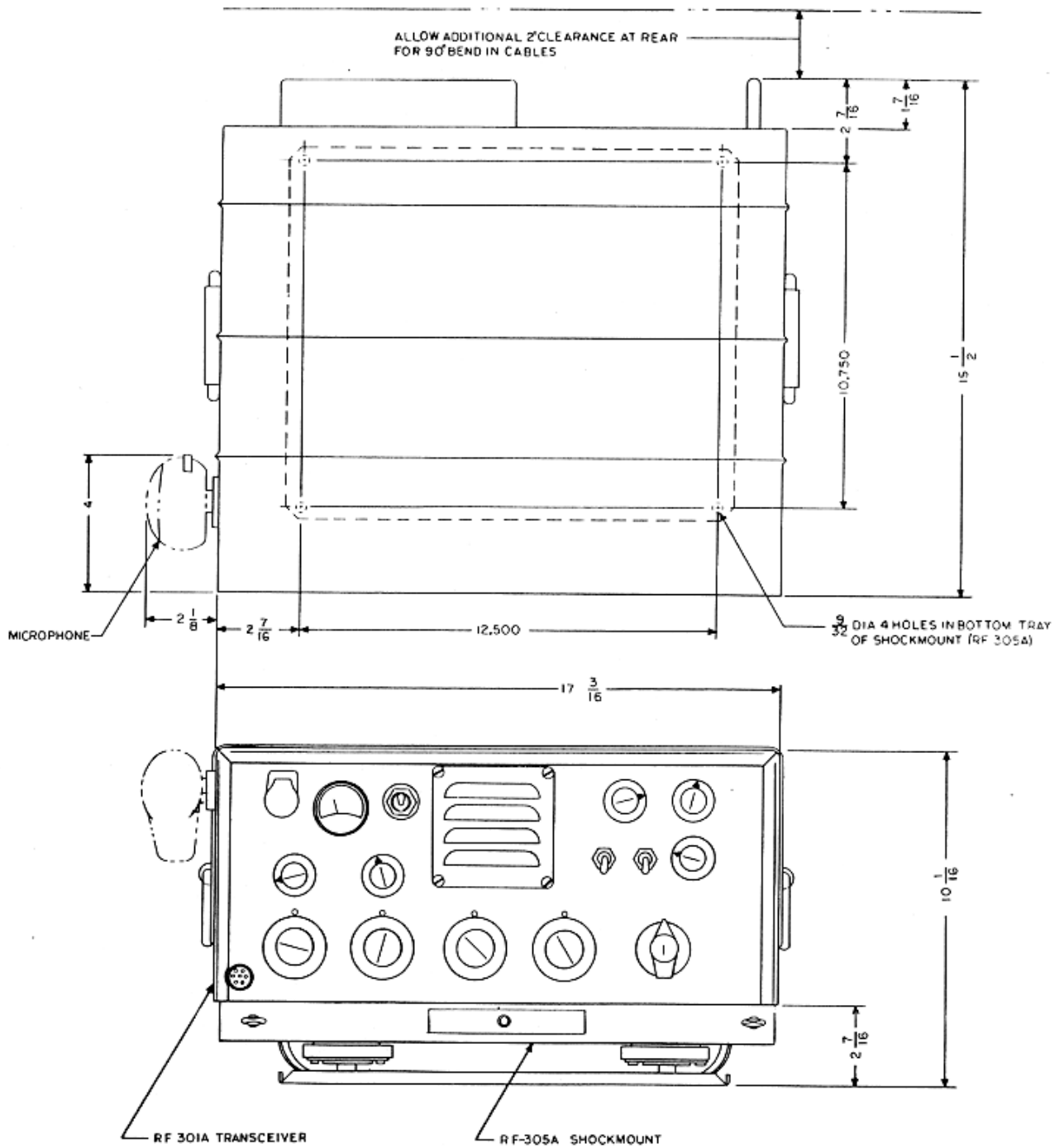

Figure 2.2 – DC Power Module Connections

NOTES

1-WHEN MOUNTING NEXT TO WALL OR ADJACENT EQUIPMENT, ALLOW $\frac{3}{4}$ " CLEARANCE ON ALL SIDES FOR MOVEMENT OF SET DUE TO SHOCK OR VIBRATION.

Figure 2.3 – RF-301 Outline Drawing



holes in the corners of the shockmount base plate. Drill the holes, and securely bolt the shockmount base to the vehicle.

The transceiver should be set on the shockmount with the rubber feet inserted in the round portion of the key-hole slots. Tightening the screws on the front of the shockmount will lock the units in place.

When the transceiver is used in dusty locations without the shockmount, it is recommended that the accessory RF-306 Air Filter be used. It is attached directly to the bottom cover of the transceiver using the filter tray supplied with it. The filter tray should be permanently bolted to the bottom cover with its opening toward the front of the transceiver. The filter is held in the tray by means of screws threaded into the filter.

2.6 TYPICAL ANTENNA INSTALLATIONS.

The RF-301 transceiver is designed to operate into a 52-ohm resistive antenna system with a VSWR of less than 1.5/1. This may be a non-resonant whip or long wire antenna tuned by an antenna coupler to operate at the desired frequency, or resonant dipole antenna cut for operation at a particular frequency.

2.6.1 BASE STATION NON-RESONANT ANTENNAS.

For base station operation, a non-resonant whip or long wire antenna, tuned by an antenna coupler is recommended to permit efficient use of all assigned frequencies within the 2 to 15 MHz frequency range of the RF-301 Transceiver.

Whip-type antenna kits SB-V16 through V35A, ranging from 16 to 35 feet in length, are available for base operations involving communications with mobile units, or at restricted antenna locations. For optimum operation between base stations, long wire antennas, such as those constructed with the SB-A75/150 Long Wire Antenna Kit, are more effective, particularly at the lower frequencies, and are recommended. The RF-302 Antenna Coupler will match any whip-type or long wire antenna over 16 feet in length to the 52-ohm output of the RF-301 Transceiver over the 2 to 15 MHz frequency range. Shorter antennas may be used, but are not as efficient at the lower frequencies.

Instructions for the installation of the SB-V16 through SB-V35 series Whip Antenna Kits, and the SB-A75/150 Long Wire Antenna Kit, are included with the kits. Instructions for the installation and operation of the RF-302 Antenna Coupler are contained in its instruction manual. Typical base station installations are shown in figure 2.4.

The connection from the antenna base to the antenna insulator on the coupler should be made with the heavy, flexible insulated cable supplied, or with the insulated inner conductor from a length of RG-8/U cable. **THIS LEAD MUST BE LESS THAN 2-1/2 FEET IN LENGTH.** All connections must be secure. If the antenna lead will be subject to movement, it should be supported in a few places by high voltage standoff insulators of the material and size used on the rear of the coupler. The type of insulator used on the coupler is recommended for installations in which the antenna lead must go through a bulkhead to reach the antenna.

When the antenna coupler is mounted near the transceiver, the antenna lead will radiate some amount of RF energy. Therefore, any connections to the REMOTE connector on the transceiver should be made using shielded wire to avoid RF pickup.

Coaxial connection from transceiver to antenna coupler should be made with 50 ohm coaxial line-such as type RG-8/U and UHF type connectors.

Extended lengths-up to 100 feet, if necessary-of RG-8/U cable may be used between coupler and transceiver; however the lead between the coupler and antenna acts as a part of the antenna itself, radiates, and is very inefficient. It also causes mistuning of the coupler. The importance of having the antenna coupler as close as possible to the antenna cannot be over-emphasized. Likewise, any extended length of lead between the coupler and a good electrical ground acts as a part of the antenna. In addition to resulting in poor operation of the antenna system, a long ground lead may result in having an RF voltage on the coupler chassis, causing improper operation and presenting a shock hazard.

If the antenna coupler will be a considerable distance from the transceiver, it may be desirable to

TYPICAL RF-301 SYSTEMS

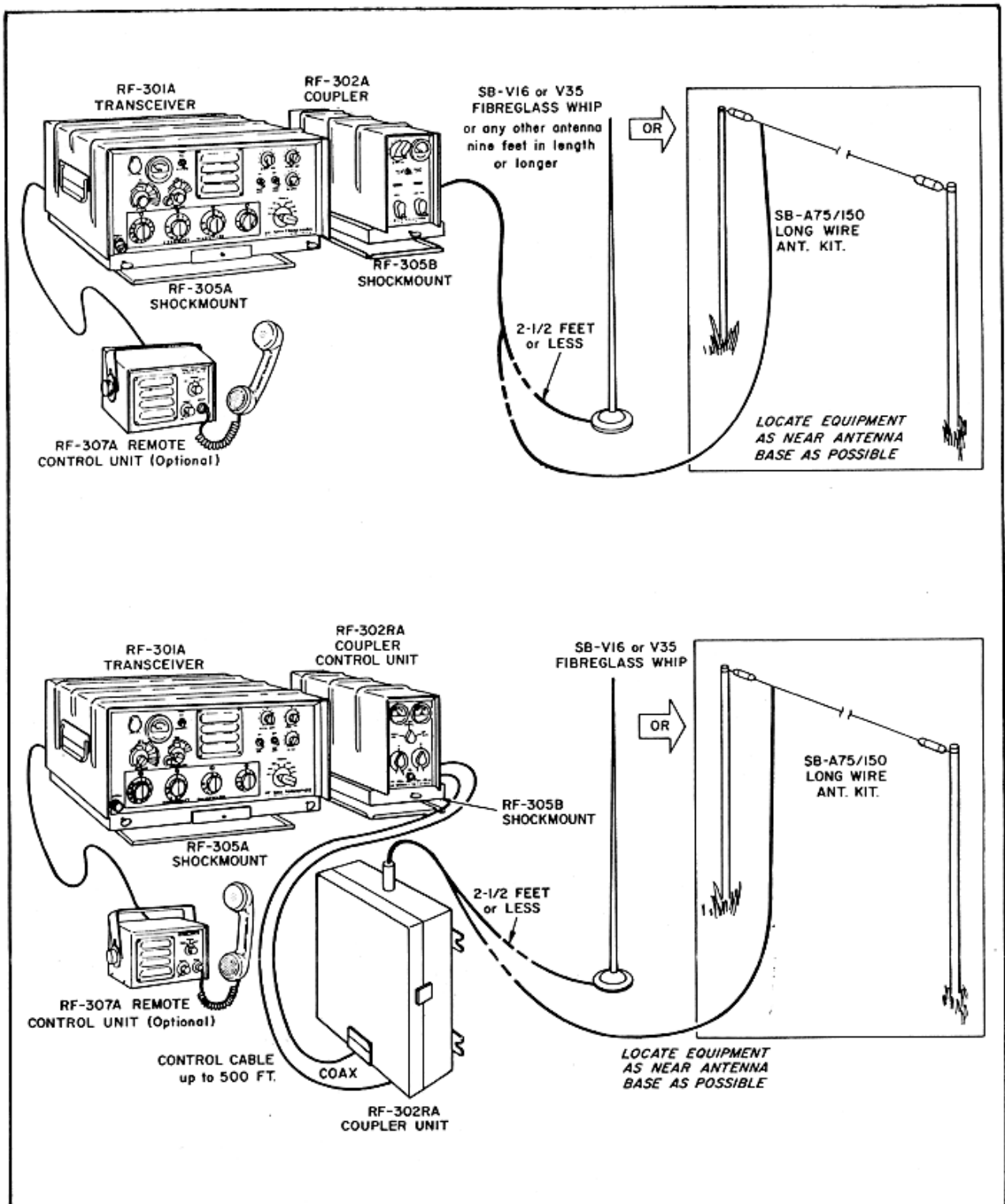

Figure 2.4 – Typical Base Station Installations



install a 50 ohm, 100 W dummy load and coaxial transfer switch near the transceiver as shown in figure 2.5. It will also be helpful to have a KEY switch at the coupler location to key the transceiver when it is desired to tune. See figure 2.5. If available, a commercial coaxial switch, such as Dow-Key's DK-78-2, should be used. Otherwise one can be constructed using a small metal box, UHF connectors, and a good quality ceramic rotary switch of the type intended for switching RF power. Leads to switch should be heavy and very short.

Both the antenna coupler and the transceiver shockmounts must have good electrical ground connections. Connections should be made with separate heavy braids (such as the braid from a length of RG-8/U cable) to the ground post on the antenna coupler and to a point at the rear of the shockmount. Remove paint on shockmount and bulkhead around areas of connection. **THE GROUND LEADS MUST BE LESS THAN 12 IN. LONG.**

A base station ground system should be a grounded pipe or a counterpoise system with ground rods driven in moist soil. The ground connection lead should be of heavy wire and as short as possible.

2.6.2 BASE STATION RESONANT ANTENNAS.

For base station resonant antenna operation, a half-wave dipole is the simplest to construct. Its operation is efficient, however, for only a narrow band of frequencies within 2-1/2% of its center resonant frequency. Separate dipole antennas must therefore, be constructed for each small band of frequencies to be used.

Using the dipole antenna at frequencies other than its resonant frequency will result in impedances that will cause a high VSWR on the transmission line, and large losses to the transmitter power output. In addition, the impedance presented to the transmitter will not be correct, causing improper operation of the transmitter itself.

The length of the coaxial cable does not affect the resonant frequency of the dipole antenna. Fifty foot of cable is supplied, but it may be necessary to add additional cable to reach the transceiver. The cable should run at right angles to the antenna for at least a quarter wavelength.

The RF-334 Doublet Antenna Kit is a self-contained doublet antenna in a molded plastic reel container. The antenna consists of two flexible metal tape elements (marked in metres), two attached support ropes, and center coaxial connector. Included separately are 50 feet of coaxial cable and a connector adaptor for connecting the antenna to the transceiver. To erect the antenna, the operator reels out the proper amount of tape, as determined by the operating frequency, and connects the coaxial cable to the center connector. The ends of the antenna are then tied to supporting objects with the rope. The doublet antenna is usually preferred for long distance communications.

NOTE

An antenna coupler is not required when using a resonant antenna. Connect the coaxial lead-in directly to ANTENNA connector on the transceiver. The use of a Balun coil (1:1 ratio at the antenna feed point) is recommended to assure radiation symmetry.

Three types of antennas can be constructed with the RF-334 Doublet Antenna Kit. All three are doublet antennas, that is, they have two legs of equal length and have one leg connected to the inner conductor of the coaxial cable and the other leg connected to the shield. The antenna elements have a combined length of an electrical half wavelength (one-quarter wavelength for each element).

A horizontal doublet can be erected as shown in figure 2.6 by suspending the antenna by its ends between two trees or other tall objects.

If only one tall support is available, an inverted V antenna can be constructed as shown in figure 2.7. In this case, the antenna is suspended from the supporting structure with nylon cord or any other insulating cord and the two legs are tied at the ends to stakes in the ground. For best operation, an inverted V should have an angle of about 90° between elements. In practice, angles between 90° and 120° are permissible.

Because the ends of an inverted V antenna are close to ground and because ground properties vary with location, it is advisable to insert an SWR bridge in the coax feed line and prune the ends until the lowest SWR is obtained.

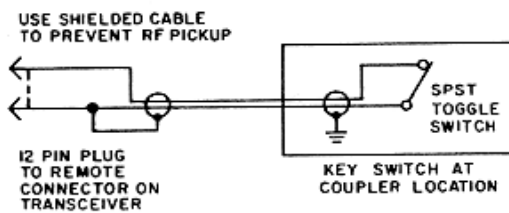
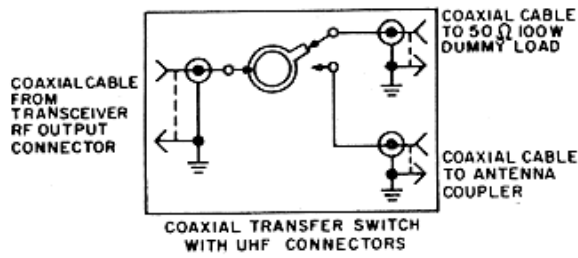
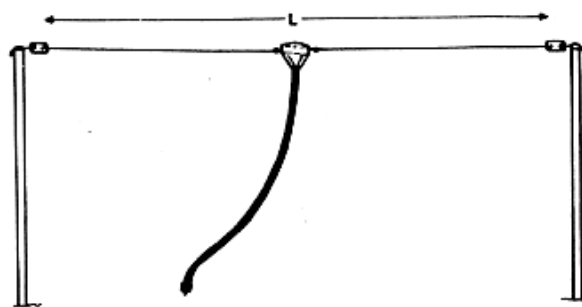

Figure 2.5 – Dummy Load and Key Switches



$$\begin{aligned} \text{TOTAL ANTENNA LENGTH} \\ \text{FEET} &= \frac{468}{\text{FREQ (MCS)}} \\ \text{METERS} &= \frac{142.5}{\text{FREQ (MCS)}} \\ \text{POLE HEIGHT 20 FT OR} \\ &7 \text{ METERS MINIMUM} \end{aligned}$$

Figure 2.6 – Doublet Antenna Construction Data

Another variation of the doublet is the slanted doublet antenna, not shown. A slanted doublet antenna is a combination of the horizontal and inverted V; that is, one end is secured to a tall vertical support, the other end is secured to a stake driven into the ground. This antenna may provide better results for some forms of propagation such as long skip or operation with another nearby station using a whip antenna.

All of these antennas are directional in nature, with the antenna providing better response to received signals from directions perpendicular to the antenna and radiating more of the transmitted signal in those directions than in others.

With any of these types of antennas, the procedure for installing the antenna is basically the same. The only variations are in the method of suspension and the points at which the ends are tied. Assemble the antenna as follows:

- a. Unreel the required lengths of metal tape from the reel. Metre markers are provided on the tape

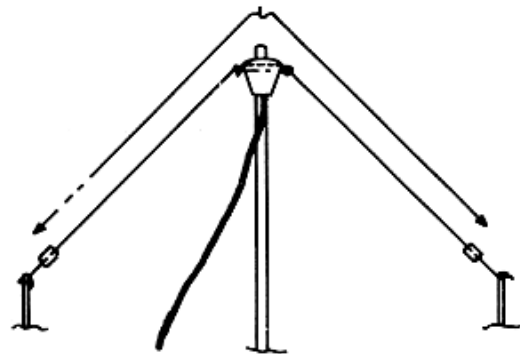

$$\begin{aligned} \text{TOTAL ANTENNA LENGTH} \\ \text{FEET} &= \frac{490}{\text{FREQ (MCS)}} \\ \text{METERS} &= \frac{149}{\text{FREQ (MCS)}} \\ \text{POLE HEIGHT APPROX} \\ &\frac{1}{3} \text{ ANTENNA LENGTH} \end{aligned}$$

Figure 2.7 – Inverted V Antenna Construction Data

and a table for conversion of metres to frequency is provided on the reel assembly. The length of each element can also be determined by the use of the formulas in figure 2.6 or 2.7. Allow proportionate additional lengths to compensate between markers for other frequencies. The antenna elements must be very close to the correct resonant lengths to provide proper operation. The transmitter can be damaged by operation with improper antenna lengths.

b. Secure the tape to the reel assembly using the wing nuts on the top of the assembly.

c. Unreel the coaxial cable and connect one end to the connector on the reel assembly. Connect the other end into the ANT connector on the front panel of the transceiver.

d. Determine how the antenna is to be supported. Tie ends (and the reel assembly, if necessary) to the supports or stakes using the attached rope. When tying the ends to trees, be sure to leave some slack to allow for movement of the trees in the wind.

e. Position the transceiver, if possible, so that the coaxial cable does not hang near either of the antenna elements. If the coaxial cable is run parallel to one of the elements, some detuning of the antenna may occur. The best routing of the coaxial cable is perpendicular to the antenna.

2.6.3 MOBILE ANTENNAS.

Vehicular installations generally employ 16 or 35 foot whip antennas. On small vehicles, such as jeep, a 16 foot whip is recommended. On larger vehicles or when greater efficiency is desired, a 35 foot whip should be used. During long periods of stationary operation, a long-wire antenna may be used for the lower frequencies. This may be desired because of its increased effectiveness at these frequencies. The RF-302 Antenna Coupler has been designed to match these antennas to the transceiver. Refer to the RF-302 instruction manual for antenna coupler operating instructions.

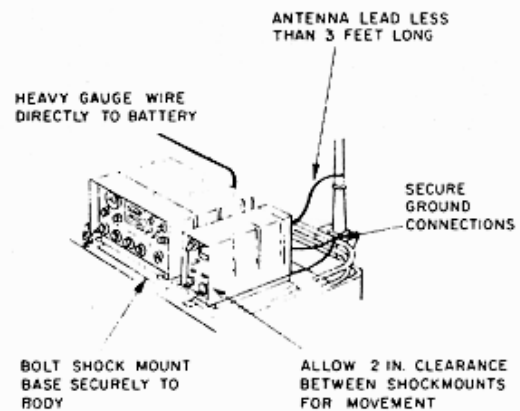

Figure 2.8 – Typical Installation in a Vehicle

2.7 ACCESSORY CONNECTIONS.

REMOTE connector J3 on the rear of the transceiver provides remote audio and keyline facilities for use with accessories. Figure 2.9 represents these facilities schematically and identifies the pin connections. Besides the nine pins used there are three spare pins. An RF #P-0401 plug should be used to mate with J3.

The RF-307 Remote Audio Control is supplied with a cable that will connect to REMOTE connector J3 on the transceiver.

When the RF-307 Remote Audio unit is operated from the 12 VDC power supply in the RF-301 transceiver, the SPEAKER SWITCH on the RF-301 should be left in the off position. If it is necessary to operate both audio systems simultaneously, use of minimum permissible gain settings is recommended.

Use of high gain settings in both units at the same time may result in blowing of fuse F3 in the RF-301 12 VDC power supply at large audio signal levels. If high gain settings are required at both units, use of a separate 12 VDC, 600 ma., supply for the RF-307 is recommended.

should be left in the off position. If it is necessary to operate both audio systems simultaneously, use of minimum permissible gain settings is recommended.

Use of high gain settings in both units at the same time may result in blowing of fuse F3 in the RF-301 12 VDC power supply at large audio signal levels. If high gain settings are required at both units, use of a separate 12 VDC, 600 ma., supply for the RF-307 is recommended.

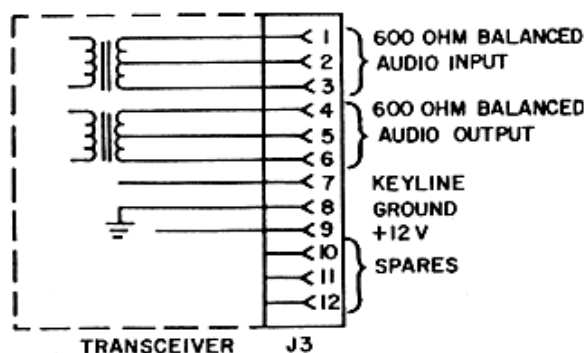

Figure 2.9 — Remote Connections

2.8 MICROPHONE, HEADPHONE, AND CW HAND KEY CONNECTIONS.

The microphone or handset supplied with the transceiver has a connector installed which mates with the HANDSET connector on the transceiver front panel.

Headphones equipped with a type PG-0055, WE-47 or equivalent phone plug will mate with HEADPHONE jack on the front panel. However, when headphones are connected, the audio signal is removed from the front panel HANDSET connector.

Other microphones and devices such as a CW hand key must be wired to a 7 pin (RF P/N P-0400) plug in accordance with information given in table 2.2. All devices are connected between a signal line and a ground line. If the microphone cable has a shield, the shield should be grounded.

Table 2.2 — Handset Plug Connections

PIN NO.	FUNCTION
1	Spare
2	Carbon Mic.
3	Earphone
4	Ground
5	Dynamic Mic.
6	Ground
7	Key line or CW Key

SECTION 3 OPERATION

3.1 GENERAL DESCRIPTION.

The RF-301 is a completely self-contained transmitter and receiver designed for simple operation and ease of tuning. It will transmit and receive SSB (USB or LSB), AM, CW, and FSK signals in the frequency range of 2 to 15 MHz. A frequency synthesizer employing a highly stable frequency standard is used for digital frequency selection. Vernier tuning between even channel frequencies is provided for both receiving and transmitting.

3.2 DESCRIPTION OF CONTROLS, INDICATORS AND CONNECTORS.

The front panel operating controls, connector and meter are shown in figure 3.1. The rear panel controls and connectors have already been described in Section 2. The functions of the front panel controls are described in table 3.1.

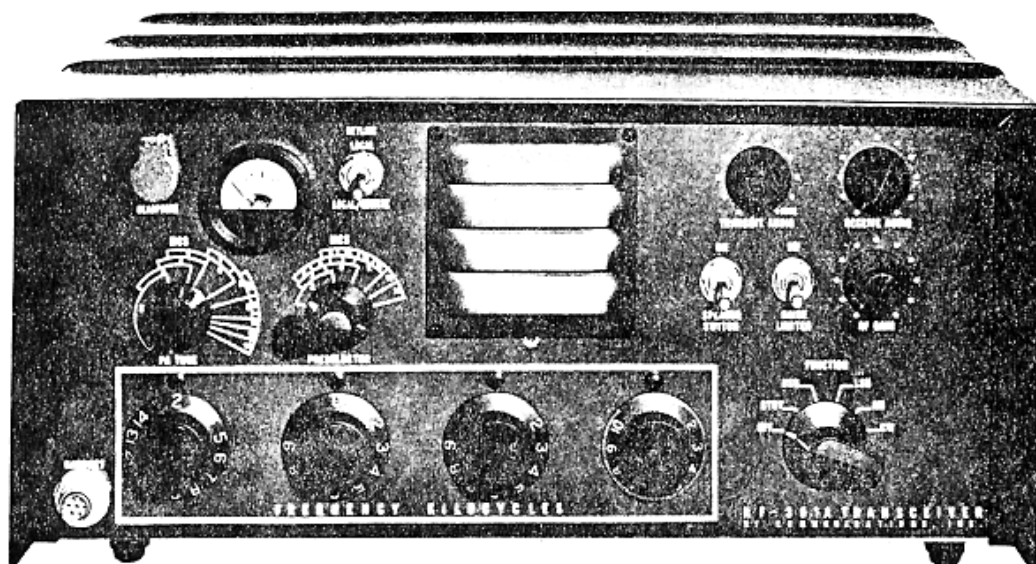

Figure 3.1 – Front Panel Operating Controls



Table 3.1 – Front Panel Devices

FUNCTION SWITCH	
OFF	Disconnects primary power from set.
STDBY	Applies power to circuits requiring warmup prior to operation.
USB	Applies full power to set and selects Upper-Sideband mode of operation.
LSB	Applies full power to set and selects Lower-Sideband mode of operation.
AM	Applies full power to set and selects compatible AM mode of operation.
CW	Applies full power to the set and selects CW mode of operation. Transmitter switches and is held on for one-half second by closing hand (code) key.
FREQUENCY KILOCYCLES Switches	
	Select operating frequency in increments of 1000, 100, 10 and 1 kHz, respectively, from left to right. In addition, the 1 kHz (righthand) knob may be pulled out to allow vernier tuning between channels.
HANDSET Jack	
	Connector for local handset, microphone, or hand-key.
P A TUNE	
	Used to tune transmitter output for peak indication on meter.
PRESELECTOR	
	Used to tune receiver RF amplifier for maximum signal strength and transmitter driver stage for maximum transmitter output. A lock is provided to prevent movement of the PRESELECTOR once tuning is accomplished.
Meter	
	Indicates signal strength on receive and RF output on transmit.
RECEIVER AUDIO Gain Control	
	Controls local audio level.
TRANSMIT AUDIO Gain Control	
	Controls transmitter drive level. TUNE position limits RF output to 25 W for tuning.
RF GAIN Control	
	Controls receiver sensitivity
NOISE LIMITER Switch	
	Turns noise limiter on and off.
SPEAKER SWITCH	
	Mutes speaker in OFF position
HEADPHONE Jack	
	Connector for local headphones to monitor audio signals. When in use audio is disconnected from HANDSET connector.
KEYLINE Switch	
LOCAL	Disconnects keyline from rear panel REMOTE connector. Transceiver can be keyed at HANDSET connector only.
LOCAL/REMOTE	Transceiver can be keyed at either the REMOTE or HANDSET connector.

3.3 FREQUENCY SETTING.

The operating frequency is selected by setting the FREQUENCY switches, one for each digit, as you would write the frequency in kilo-Hertz. The pointers over the knobs point to the numbers se-

lected. The left hand knob indicates in multiples of 1,000 kHz, the second knob in multiples of 100 kHz, the third in multiples of 10 kHz, and the fourth in multiples of 1 kHz. Thus, to operate on 3,259 kilo-Hertz (kHz), set the switches, from left to right, on 3, 2, 5, and 9. Vernier tuning, between even 1 kHz increments, can be accomplished by pulling the right hand frequency knob out. It will then tune smoothly from 0 to 10 kHz. The lines on the knob mark off 100 Hz (0.1 kHz) increments. Rotate the knob and push toward the panel to lock the switch in digital operation when vernier tuning is not used.

3.4 PREPARATION FOR OPERATION.

When applying power to sets not at normal operating temperature, turn the FUNCTION switch to STBY and allow the tube heaters to warm up for a few minutes before operating.

CAUTION

Never key the transmitter without having an antenna or a 52Ω , 200 W dummy load connected.

3.5 OPERATION

Operating with headphones connected is the same as with a HANDSET or using the front panel speaker. Set RECEIVE AUDIO gain control for a comfortable listening level.

NOTE

If headphones are used, the received audio signal is disconnected from the handset.

3.5.1 RECEIVER ADJUSTMENTS.

The following procedure should be used to set the operating controls for receiving.

- Warm up set as explained in paragraph 3.4.
- Select frequency as explained in paragraph 3.3.



- c. Set FUNCTION switch to desired mode.
- d. Turn SPEAKER SWITCH to ON position.
- e. Set RF GAIN control to maximum clockwise position. Set TRANSMIT AUDIO control fully clockwise to TUNE detent.
- f. Set RECEIVE AUDIO gain control for comfortable listening level.
- g. Set the PRESELECTOR control somewhat below the lower limit of MHz band to be used and tune up into band for first noise peak.

NOTE

It is possible to turn the PRESELECTOR to spurious signals at other points on the dial, particularly above the selected frequency. By starting below this frequency and tuning upward to it, the chances of tuning to a spurious signal are minimized. Check PRESELECTOR dial indication to insure it is peaked near the proper frequency, allowing for calibration errors.

- h. To tune to a transmitted signal rotate the TRANSMIT AUDIO control fully counterclockwise and tune PRESELECTOR for peak indication on meter. If the signal appears to be off-frequency, use vernier (VFO) tuning as described in paragraph 3.3.

- i. Readjust RECEIVE AUDIO gain control if necessary. If ignition or other pulse type noise becomes objectionable, turn NOISE LIMITER ON.

NOTE

The RF GAIN control is normally left fully clockwise for maximum sensitivity, but can be turned down for extremely strong signals or to reduce the background noise. By setting the RF GAIN control so that the S-meter fluctuates only about 1/2 S-unit during a period of reception, background noise normally heard between speech syllables is reduced considerably.

3.5.2 TRANSMITTER ADJUSTMENTS.

The following procedures should be used to set the operating controls for transmitting:

- a. Perform steps listed for receiver operation in paragraph 3.5.1.
- b. Turn TRANSMIT AUDIO control fully clockwise to TUNE position detent.

NOTE

Power output is limited to 25 watts for tuning purposes.

- c. Preset PA TUNE control to approximate frequency on scale.

NOTE

If a resonant antenna system is used, the transmitter must be tuned within the band of frequencies at which the antenna is resonant.

- d. Place the FUNCTION switch in CW position. Set KEYLINE switch to LOCAL.
- e. Plug microphone or handset into HANDSET jack. Depress the microphone switch or key.
- f. Adjust PA TUNE for maximum output.

CAUTION

This equipment may be damaged if transceiver is set for more than 25 watts output before antenna coupler is tuned.

- g. Tune the associated antenna coupler, if used, according to the instruction manual supplied with it.



h. Release the microphone switch or hand key. Turn TRANSMIT AUDIO control fully counterclockwise. Depress the microphone switch or CW hand key and advance the TRANSMIT AUDIO control until 25 to 50 watts output is indicated.

i. Re-adjust PRESELECTOR control (slightly) for maximum output. Secure PRESELECTOR control from movement by tightening the PRESELECTOR lock.

j. After both transmitter and antenna are tuned, advance the TRANSMIT AUDIO control to point where maximum power indication on the meter is first obtained. Advance TRANSMIT AUDIO control the equivalent of two of its dial divisions beyond this point, and readjust the PA TUNE control for peak indication on the meter. Note the amount of this indication and then turn TRANSMIT AUDIO control fully counterclockwise.

k. Unkey transmitter and select desired operating mode (i.e., USB, LSB, AM, or CW). Key transmitter and advance TRANSMIT AUDIO control to the point where the maximum indication on the meter during voice modulation peaks is equal to the amount noted at the end of step j above. Advance TRANSMIT AUDIO control the equivalent of one of its dial divisions beyond this point.

NOTE

Advancing the TRANSMIT AUDIO control appreciably beyond this setting will greatly increase distortion of the transmitted signal, but will have little effect on peak power output.

3.5.3 KEYING THE TRANSMITTER.

NOTE

Remote keying of the transceiver can be inhibited by setting the KEYLINE switch at LOCAL. This permits keying by the local operator only. If keying by both a local operator and a remote operator is desired, set the KEYLINE switch at LOCAL/REMOTE.

When operating on SSB or AM, press the microphone button to key the transmitter.

When operating on CW, the transceiver will automatically transmit as you begin sending and return to receive when you stop sending.

3.6 OPERATOR MAINTENANCE.

The air filter, if used, should periodically be removed and cleaned. The filter tray on the shockmount may be removed by loosening its screw and sliding it forward. The filter on the transceiver base plate when the shockmount is not used may be detached by removing the screws holding the filter in the tray. The filter can then be slid out from the tray and cleaned.

To clean the filter, first remove loose dirt by rapping filter gently on a hard surface. Then, wash the filter with hot, soapy water. Rinse and dry filter thoroughly. After cleaning reinstall filter and tray.

SECTION 4

PRINCIPLES OF OPERATION

4.1 FUNCTIONAL DESCRIPTION.

The RF-301 Transceiver is a triple-conversion superheterodyne receiver and transmitter, tunable over the high-frequency range of 2-15 MHz.

Digital frequency selection is accomplished by setting four controls on the front panel. These controls establish the operating frequency in multiples of 1000 kHz, 100 kHz, 10 kHz, and 1 kHz, respectively, from left to right on the panel. The displayed frequency is read on the knobs under the pointers and is variable in 1 kHz steps. The frequency is precisely controlled by a highly stable frequency standard. The synthesizer can be unlocked, and the transceiver can be tuned to any "off-channel" frequency if desired. Vernier tuning is calibrated on the knob in 100 Hz (0.1 kHz) increments. The 1 kHz knob is pulled out and tuned continuously rather than in 1 kHz steps.

The transceiver will operate in the USB, LSB, AM and CW modes and will provide a minimum of 100 watts PEP output in any of these modes. Audio and keying facilities are provided for in both local

and remote operation. The transceiver will operate on 115 and 230 VAC, 50-60 Hz, single phase; and 13.5 or 26.0 VDC primary power.

4.2 MAIN SIGNAL FLOW.

The RF-301 Transceiver, with the exception of the frequency synthesizer, is a straight-forward triple conversion superheterodyne circuit. Consider the frequency synthesizer as a "block box" which generates all of the internal frequencies for injection to the various mixers in the transceiver. Refer to the simplified block diagram in figure 4.1.

There are two main signal paths, one for receiving and one for transmitting. Arrow heads marked "T" indicate the direction of transmit signal flow, and those marked "R" show the direction of the receive signal flow. When receiving, the signal from the antenna is connected by the antenna transfer relay through Receiver Protector assembly to the RF Amplifier assembly. The amplified signal is fed into the Translator assembly, which contains a series of three mixers and two filters. The frequency synthesizer supplies the injection frequencies required

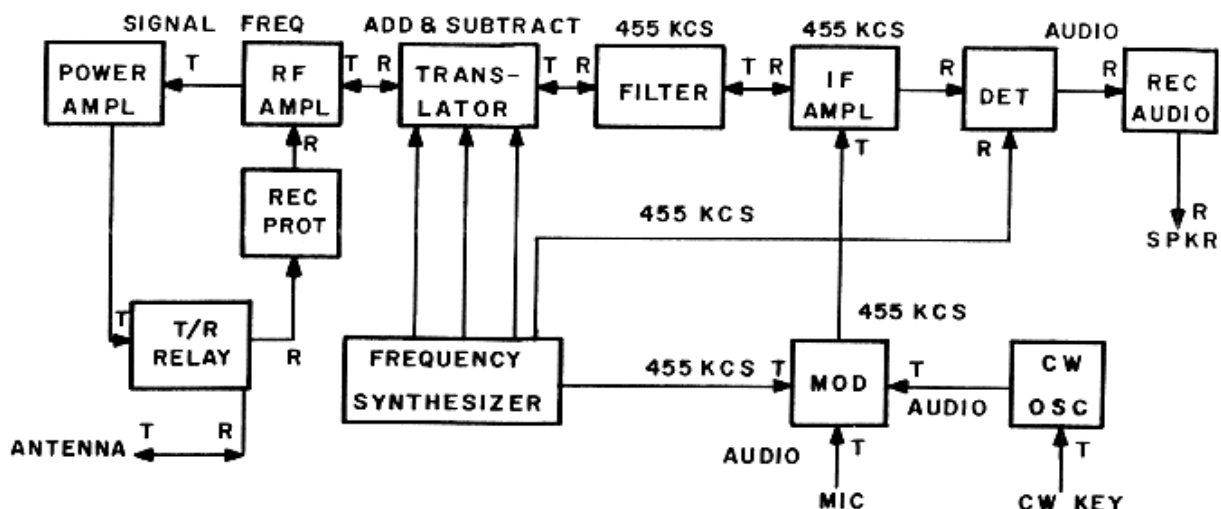

Figure 4.1 — RF-301 Simplified Block Diagram, Illustrating Signal Flow



for the mixers. The Translator first raises the received signal to a frequency slightly above 17 MHz, and then, in two more steps, it converts the signal to frequencies of 11.1 MHz and 455 kHz. The Translator output at 455 kHz is fed through a filter assembly where the filter with the appropriate passband for the mode of operation is selected by the FUNCTION switch on the front panel of the transceiver. No filter is used for AM reception. The output from the IF Amplifier assembly is demodulated by either the AM or SSB detector, and the resultant audio signal is amplified by the Audio Amplifier assembly and fed to the speaker.

The transmit signal flows much the same as the receive signal, but in the opposite direction. Audio from the microphone or CW oscillator is amplified by an audio stage and modulates the 455 kHz injection frequency at the balanced modulator. The IF Amplifier, Translator and RF Amplifier assemblies perform the same functions as when receiving, but in the opposite sequence. The modulated 455 kHz signal is amplified by the IF amplifier assembly and the unwanted sideband is attenuated in a filter selected by the mode switch. The modulated and filtered 455 kHz signal is converted to the operating frequency in the Translator assembly. In AM mode, the carrier is re-inserted at the point where the signal enters the Translator. The RF Amplifier assembly acts as a driver for the power amplifier (PA) stage. The antenna transfer relay connects the PA output to the antenna. The RF amplifier and PA stages are tuned by combinations of fixed capacitors selected by the 1000 kHz frequency switch and variable inductors adjusted by the PRESELECTOR and PA TUNE controls.

4.3 FREQUENCY SYNTHESIZER.

The frequency synthesizer generates the frequencies used in the superheterodyne frequency-conversion process. It employs crystal oscillators, error mixers, frequency dividers, spectrum generators and a frequency standard as shown in figure 4.2. The synthesizer, in effect, generates the desired frequencies with accuracy and stability matching those of the precise frequency standard.

4.3.1 ERROR MIXERS.

As shown in figure 4.2, the crystal oscillator output, with a certain frequency error, is fed into the

Translator. The same output is fed into an error mixer, which compares the oscillator frequency and a frequency from a spectrum generator. Since the spectrum generator derives its accuracy from the frequency standard, the error mixer produces an output containing the combined errors of the frequency standard and the crystal oscillator. The error of the frequency standard is negligible compared to that of the crystal, so we consider it as being non-existent. Thus the error mixer output consists of a new frequency which contains the same amount of error as that of the crystal oscillator. Because of the algebraic method in which the error mixer subtracts the crystal oscillator frequency from the spectrum frequency, the relationship between the error and the frequency is reversed. If the crystal oscillator has a positive error (high in frequency) the error mixer output frequency will have a negative error (low in frequency), and vice-versa.

4.3.2 ERROR CANCELLING.

The error mixer output frequency, with its reversed error, is fed into the Translator. The Translator mixes this frequency and its reversed error with the signal and its error inherited from the crystal oscillator. The crystal oscillator error and the reversed error cancel, and a new frequency is produced with no error other than the frequency standard error.

4.3.3 SYNTHESIZER SIGNAL FLOW.

The error cancelling system, as described, illustrates the manner in which one oscillator frequency error is cancelled. In actual operation, there are four crystal oscillators, and the synthesizer has many error signal paths and many frequencies generated for its own operation. Referring to figure 4.3, the frequency standard operates at 1 MHz. The dividers and spectrum generators use this frequency to generate spectrums of frequencies in multiples of 1 MHz, 100 kHz, 10 kHz, and 1 kHz. Each spectrum contains at least 10 distinct frequencies. Each pair of spectrums and oscillator frequencies is mixed and filtered so that only the desired mixer product is derived. There are two error mixer assemblies. One has an output at approximately 11.6 MHz, and the other has an output at approximately 455 kHz. Each output contains a reversed frequency error. The 11.6 MHz error signal is fed into the Translator, and the 455 kHz error signal is fed into the SSB balanced modulator/detector.

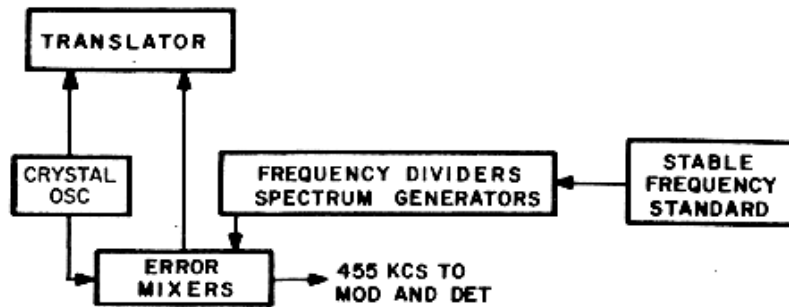

Figure 4.2 – Frequency Synthesizer Simplified Block Diagram, Illustrating Error Loop

Refer to figure 4.6 at the end of this section. It is a block diagram of the entire transceiver, showing all of the assemblies and their stages. It includes signal paths and passband frequencies of the filters in the synthesizer assemblies. Notice that the filters do not pass only one frequency, but a band of frequencies. However, only one of the mixer products will pass through the filter in any of the many possible frequency combinations. Notice, too, that the frequencies are mixed in successive steps in the Error Mixer and Translator assemblies. Figure 4.6 also shows the method of changing IF sideband filters with the operating mode.

Table 4.1 shows the crystal oscillator frequency responding to each FREQUENCY control setting. It also shows the spectrum frequencies used in each generated spectrum.

Table 4.1 – Crystal Oscillator and Spectrum Frequencies

CRYSTAL OSCILLATOR FREQUENCIES (MHz)				
DIGIT	MHz OSC	100 kHz OSC	10 kHz OSC	1 kHz OSC
0	—	6.147	1.8465	0.7985
1	—	6.247	1.8365	0.7975
2	15.247	6.347	1.8265	0.7965
3	14.247	6.447	1.8165	0.7955
4	13.247	6.547	1.8065	0.7945
5	12.247	6.647	1.7965	0.7935
6	11.247	6.747	1.7865	0.7925
7	10.247	6.847	1.7765	0.7915
8	9.247	6.947	1.7665	0.7905
9	8.247	7.047	1.7565	0.7895
10	7.247	—	—	—
11	6.247	—	—	—
12	5.247	—	—	—
13	4.247	—	—	—
14	3.247	—	—	—

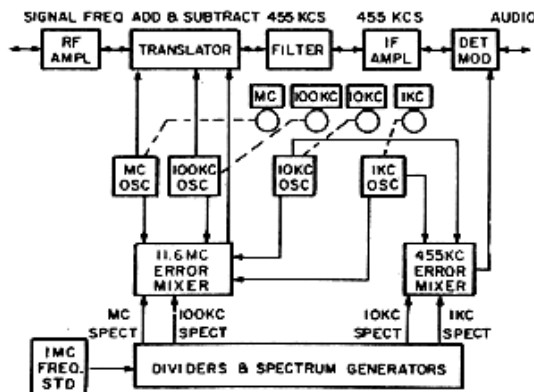

Figure 4.3 – Frequency Synthesizer Block Diagram, Illustrating Signal Flow

SELECTED SPECTRUM FREQUENCIES (MHz)

CORRESPONDS TO DIGIT	MHz SPECT	100 kHz SPECT	10 kHz SPECT	1 kHz SPECT
0	—	28.1	1.20	1.900
1	—	28.2	1.19	1.899
2	23.0	28.3	1.18	1.898
3	22.0	28.4	1.17	1.897
4	21.0	28.5	1.16	1.896
5	20.0	28.6	1.15	1.895
6	19.0	28.7	1.14	1.894
7	18.0	28.8	1.13	1.893
8	17.0	28.9	1.12	1.892
9	16.0	29.0	1.11	1.891
10	15.0	—	—	—
11	14.0	—	—	—
12	13.0	—	—	—
13	12.0	—	—	—
14	11.0	—	—	—

4.3.4 VERNIER TUNING.

Vernier tuning is possible when the 1 kHz frequency knob is pulled out. The Variable Frequency Oscillator (VFO) is substituted for the 1 kHz Crystal Oscillator in this case. When using the vernier feature, however, complete error cancellation does not occur. It is necessary to substitute a fixed frequency oscillator for part of the 455 kHz Error Mixer to obtain the 455 kHz Error Mixer output. This is accomplished automatically when the VFO is turned on. The sacrifice in accuracy is not too significant under normal operating conditions, however, since the higher frequency error cancelling loops are still in operation.

4.4 POWER SUPPLIES.

The power supplies in the transceiver are represented by the block diagram in figure 4.4. A switch on the rear panel selects 115 VAC, 230 VAC or the DC converter to be connected to the transformer primaries. The DC converter, either RF-303 or RF-304, is a separate module, which converts 13.5 or 27.5 VDC to AC for use in the transformer. It is a transistor square-wave oscillator.

Secondaries of the power transformer supply the various voltages used in the transceiver. Rectifiers

and filters are used for the DC supplies. The RF amplifier bias supply is voltage regulated. A potentiometer adjusts the PA bias voltage. The 12 VDC supply for most of the transistor stages incorporates an electronic filter which greatly reduces the voltage ripple. The DC output for the relays in the transceiver is unfiltered.

4.5 T/R SWITCHING.

When changing from receive to transmit in the transceiver, it is necessary to reverse the direction of signal flow in many of the stages. Essentially, two methods are employed in the RF-301.

The first method consists of using relays. This is done in the RF amplifier and antenna circuits. One relay switches the antenna from the Receiver Protector input to receive to the PA stage output in transmit. Another relay reverses the input and output of the RF amplifier assembly when changing from receive to transmit.

The second method consists of using biased diodes for switching. This method is used primarily in the Translator assembly. A back-biased diode offers a very high impedance to RF signals, and a forward-biased diode offers a low impedance to RF signals.

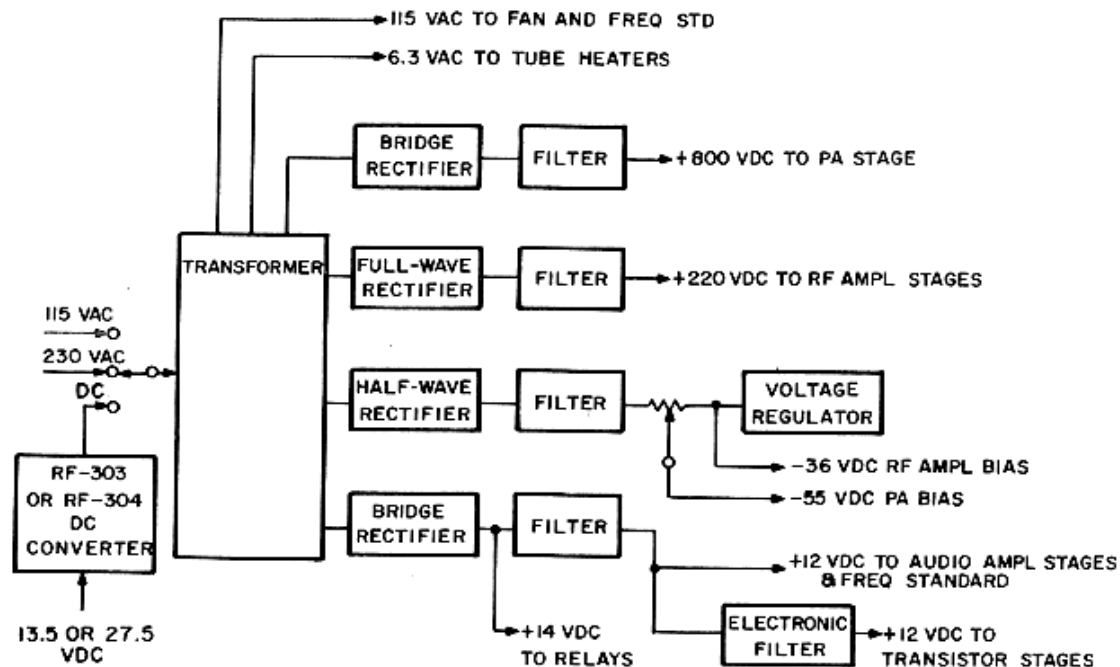

Figure 4.4 - Power Supply Block Diagram

By decoupling the DC control lines from the RF signal circuitry, many RF signal paths can be turned off and on by proper biasing of a control line. Two diodes and control lines are used in each case. The voltage is applied to one line and the other line is grounded, causing only one diode of the pair to conduct at any particular time. When changing from receive to transmit, the situation is reversed and the other diode conducts. Thus, the diodes act to "steer" the signal on either path, receive or transmit. See figure 4.5.

In other cases, such as in the IF Amplifier assembly, two sets of circuits are used, and the control lines just supply the operating voltage to the desired circuits.

4.6 AGC, ALC, AND ACC AUTOMATIC CONTROL CIRCUITS.

There are three types of automatic signal level controls employed in the RF-301. These are AGC (Automatic Gain Control), ALC (Automatic Level Control) and ACC (Automatic Carrier Control).

An AGC Circuit in the IF Amplifier assembly provides an output in proportion to the received signal strength. The AGC voltage regulates the gain of the IF and RF amplifiers and compensates for wide variations in signal strength while receiving.

An ALC circuit, used in conjunction with the PA stage, limits the peak level of the signal driving the PA stage.

An ACC circuit controls the level of the carrier reinserted during AM transmissions.

Operation of the AGC circuit is described in paragraph 4.7.4. Operation of the ALC and ACC circuits is described in paragraph 4.7.1.

4.7 CIRCUIT DESCRIPTIONS.

Refer to block diagram figure 4.6 during the following descriptions. It is located at the end of this section.

4.7.1 PA SECTION.

The PA section consists of the PA stage, antenna transfer relay, output metering circuit, ACC circuit and ALC circuit.

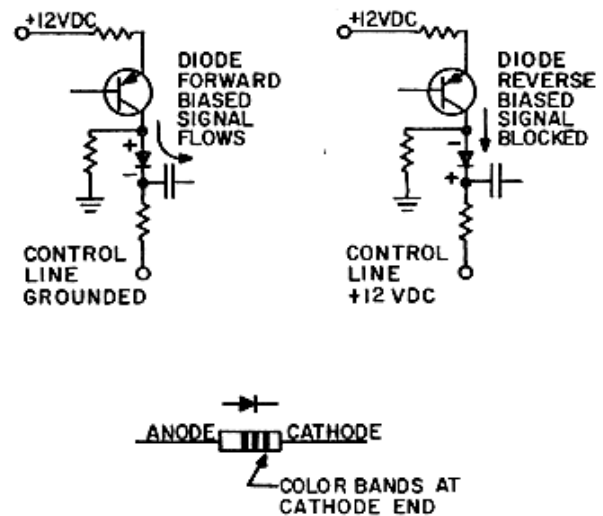

Figure 4.5 - Switching Diodes

The PA stage employs three tubes, operating as class AB₁ power amplifiers. The drive signal is provided by the RF Amplifier assembly. The output of the PA stage is coupled to the antenna through a pi-network. The output network is tuned by a variable inductor, adjusted by the PA TUNE control, and fixed capacitors, switched into the circuit by the 1000 kHz FREQUENCY control. The antenna relay connects the output network to the antenna when transmitting.

The output metering circuit consists of RF output detector CR22 and buffer Q3. A small portion of the RF output is rectified by CR22. The resultant DC is fed through buffer stage Q3 to the transceiver's panel meter during transmit operation. The meter indicates the output power level.

The ACC circuit assembly 16, consists of an input network, buffer stage Q1, and DC amplifier stage Q2. The input network removes the effects of amplitude modulation and applies a voltage to Q1 in proportion to the carrier level only. The buffer output is averaged by an R-C network and is fed to DC amplifier stage Q2. A potentiometer in the DC amplifier stage sets the desired carrier level. The output of the DC amplifier regulates the gain of the carrier control stage in the 455 kHz Error Mixer assembly. The effect of this automatic control is to prevent overmodulation in AM and provide a uniform carrier level over a wide range of operating frequencies.



The ALC circuit, assembly 15, consists of three dc amplifiers, Q1, Q2, and Q3, in series. Rectification of the positive peaks of heavily modulated RF drive signals at the PA/grids develops negative voltage pulses at the base of transistor Q1. These pulses are amplified sufficiently by Q1, and Q2 to trigger Q3 into conduction and charge capacitor C4 to a positive level. The output at pin D, supplied by C4, is a voltage proportional to the recurrence rate of the pulses. This voltage is applied to the transmit IF stage in the IF amplifier, limiting the amplitude of the drive signal to the PA grids. Without ALC operation, the normal class AB1, bias of the PA stages would change whenever appreciable amounts of grid current occurred (on heavy modulation peaks) resulting in excessive distortion of the output signal.

4.7.2 RECEIVER PROTECTOR ASSEMBLY.

The receiver protector assembly, located on the main frame, protects the sensitive input circuits of the RF amplifier from damage by any excessively strong signals that have been received by the antenna.

The receiver protector assembly consists of relay K1, relay driver transistor Q2, and associated circuitry. Relay K1 is de-energized during normal receiver operation. This applies the input RF signal from T/R relay K4 to the input of RF Amplifier Assembly-02. If an excessively strong signal is received, the positive portion detected by diode CR1, will bias Q1 into saturation, energizing relay K1. With K1 energized, the input of the RF amplifier is disconnected from the input RF signal and connected to ground. The trip level for relay K1 is determined by the value of resistors R2 and R3. This level is approximately three to six volts of RF, measured at the antenna connector.

During receiver tuning a positive dc voltage is applied to the base of Q1 causing relay K1 to energize and grounding the input of the RF Amplifier. This reduces the possibility of tuning to a spurious signal. The positive dc voltage is supplied from the +12 VDC R/T line and is grounded out through a resistor during normal operation. When the TRANSMIT AUDIO control is set at TUNE the +12 VDC is applied to the base of Q1 through diode CR3.

4.7.3 RF AMPLIFIER ASSEMBLY.

The RF Amplifier assembly consists of RF amplifiers V1 and V2, AGC amplifier Q1, and transfer

relay K1. The RF Amplifier assembly operates on both receive and transmit. The RF amplifiers operate in class A. Their gain is controlled, in the presence of a strong received signal, by the AGC signal amplified by Q1. The input and output networks are tuned by a combination of fixed capacitors switched by the 1000 kHz FREQUENCY control and variable inductors adjusted by the PRESELECTOR control. The input signals on receive and transmit and the output signal on receive are switched by transfer relay K1. The output on transmit is taken directly from the output network. In receive, the RF amplifiers serve to amplify the received signal from the antenna and their output is applied to the Translator assembly. In transmit, the RF amplifiers serve to amplify the Translator output and drive the PA stage.

4.7.4 TRANSLATOR ASSEMBLY.

The Translator consists of mixers Q1, Q2, and Q3, and two filters.

During receive operation, the signal frequency is added to the MHz Oscillator frequency in Q1 to produce a new frequency at approximately 17.748 MHz, which is passed through filter FL1. In Q2, the 100 kHz Oscillator frequency is subtracted from the signal from FL1 to produce a new frequency at approximately 11.1515 MHz. This signal from Q2 is passed through FL2. In Q3, the signal from FL2 is subtracted from the error mixer frequency of approximately 11.6 MHz to produce a new signal frequency of approximately 455 kHz. This signal frequency is passed through the appropriate 455 kHz sideband filter, selected by the FUNCTION switch, to the IF Amplifier assembly.

During transmit operation, the process is reversed. The 455 kHz signal is applied to Q3, and the inputs and outputs of the mixers are reversed as discussed in Section 4.5. In AM operation the 455 kHz carrier is reinserted at P10 along with the upper sideband signal. The 455 kHz signal is subtracted from the error frequency of approximately 11.6 MHz to produce a signal at approximately 11.1515 MHz. FL2 passes this signal to Q2, where it is added to the 100 kHz Oscillator frequency to produce a signal of approximately 17.748 MHz. FL1 passes this signal to Q1 where the MHz Oscillator frequency is subtracted from it. The resultant signal at the operating frequency is applied to the RF Amplifier section.

4.7.5 IF AMPLIFIER ASSEMBLY.

The IF Amplifier assembly consists of eight transformer-coupled IF amplifier stages, a noise limiter, an AGC detector and buffer. Separate IF stages are used for receive and transmit.

On receive, the Translator output is coupled to the first IF stage through the selected 455 kHz filter. The Translator output is connected directly to the IF Amplifier Assembly on AM receive. Five IF amplifier stages are employed in a cascade arrangement. The output is coupled to a detector in the Audio/Modulator section. A noise limiter clips impulse noise peaks when turned on. Two additional IF amplifiers are used before the AGC detector. Q9 is a peak detector. AGC output is taken from the AGC buffer Q10. The AGC voltage developed is used to control the gain of the first three receive IF stages and the two RF stages in the RF Amplifier section. On transmit, the signal from the Audio/Modulator assembly is amplified by Q6 and coupled to the Translator through the selected 455 kHz sideband filter.

Changing from receive to transmit is accomplished by applying operating voltage to the proper section.

4.7.6 AUDIO/MODULATOR ASSEMBLY.

The Audio/Modulator assembly consists of an SSB modulator/detector, an AM detector, a transmit audio amplifier, a CW oscillator, a CW hold circuit and two audio amplifiers.

The SSB modulator/detector consists of a diode ring which performs the functions of a balanced modulator and SSB detector. In receive, the incoming signal is mixed with the 455 kHz injection frequency resulting in an audio output which is coupled to the first receive audio stage Q7. In transmit, the incoming audio modulates the 455 kHz injection frequency, resulting in mixer products containing a 455 kHz carrier and two sidebands. The carrier is balanced out, and only the upper and lower sidebands remain on the output. The undesired sideband is filtered out, after the IF Amplifier assembly, when the signal is applied to the Translator assembly through the selected sideband filter.

Q3 amplifies an AM signal, and its output is applied to CR4. CR4 is the AM detector. Its output is coupled to the first receive audio stage Q7.

Q7 and Q8 are audio amplifiers. The output from Q8 feeds into the Audio Amplifier section and also directly out to the remote audio output and local handset output.

Q4 amplifies the transmit audio for application to the SSB modulator. Its output also feeds into receive audio stage Q7 for sidetone monitoring on CW.

Q5 is a CW sidetone oscillator, which generates an audio tone when keyed. Q6 is a CW hold circuit, which keys the transmitter when the CW key is depressed and keeps the transmitter keyed until about 1/2 second after the key is released.

Transistor Q9 is an injection amplifier, and operates as an emitter follower driving the diode ring through transformer T6. Its function is to amplify the power and (through T6) the voltage supplied to the diode ring from the 455 kHz error mixer injection source.

Transistor Q10 is an IF amplifier which functions in LSB and USB receive modes only, serving to match the high output impedance of the IF amplifier board to the low input impedance of the diode-ring SSB detector.

4.7.7 AUDIO AMPLIFIER ASSEMBLY.

The Audio Amplifier Assembly consists of transistors Q1 through Q6 with associated circuitry.

Audio from the Audio/Modulator assembly is applied to Q1 through the RECEIVE AUDIO gain control. Transistors Q1 and Q2 are voltage amplifiers that drive a complimentary feed-back amplifier made up by transistors Q3 through Q6. The output is coupled by capacitor C4 to the front panel speaker.

4.7.8 CRYSTAL OSCILLATOR ASSEMBLIES.

The MHz, 100 kHz, 10 kHz, and 1 kHz Crystal Oscillators each consist of oscillator and buffer stages and a bank of crystals switched into the circuit by its respective FREQUENCY control. In the MHz Oscillator Assembly, Q1 operates as an oscillator and the crystals oscillate in the parallel mode. An AGC amplifier, Q2, maintains a constant output level over the frequency range of the oscillator.



Transistors Q3 and Q4 serve as the buffer stages to minimize loading of the oscillator. In the 100 kHz Oscillator assembly, Q1 operates as an oscillator and the crystals oscillate in the parallel mode. Transistor Q2 serves as the buffer stage. In the 10 kHz Oscillator Assembly, both Q1 and Q2 are used to form the oscillator circuit and the crystals oscillate in the series mode. Transistor Q2 serves as the buffer stage. In the 1 kHz Oscillator Assembly, both Q1 and Q2 are used to form the oscillator circuit. The crystals oscillate in the series mode at twice the required output frequency of the assembly. A flip-flop, composed of Q3, Q4, and associated circuitry, divides the crystal frequency by two. Transistors Q5 and Q6 serve as buffer stages.

4.7.9 VFO ASSEMBLY.

The VFO assembly consists of a three transistor oscillator circuit and a one stage amplifier. The VFO is tuned by a variable capacitor and a preset coil and padder capacitor. The tuning capacitor is mechanically coupled to the 1 kHz FREQUENCY control. The VFO operates only when the 1 kHz knob is pulled out.

4.7.10 DIVIDER AND SPECTRUM GENERATOR ASSEMBLY.

The Divider and Spectrum Generator assembly consists of 20 transistors used as amplifiers, multivibrators, pulse shapers, and keyed oscillators. Transistor Q20 acts as a buffer for the 1 MHz frequency standard. Q1 amplifies and clips the 1 MHz input signal from the frequency standard. Q14 and Q15 act as pulse shapers. The MHz spectrum output contains frequencies at 1 MHz intervals between 11 and 23 MHz. The frequency dividers are multivibrators Q2 through Q13.

They consecutively divide the frequency by 2 and 5. Their output frequencies are at 100 kHz, 10 kHz and 1 kHz. Q16 acts as a buffer for the 100 kHz output from Q5. The 100, 10 and 1 kHz spectrum generators are keyed-oscillators which produce frequencies at intervals of 100, 10 and 1 kHz respectively. They act as oscillators at the natural frequency of resonance, but since they are keyed by the frequency divider outputs, they produce a spectrum of frequencies centered about the oscillator frequency, rather than just a single frequency. For example, Q17 would normally oscillate near 28.6 MHz, but since it is keyed by the 100 kHz output from Q16, it produces at least the 10 frequencies at 100 kHz intervals between 28.1 and 29.0 MHz. Other undesired frequencies near the desired ones,

are produced at the same 100 kHz intervals, but their amplitude is considerably lower.

4.7.11 11.6 MHz ERROR MIXER ASSEMBLY.

The 11.6 MHz Error Mixer assembly consists of buffers, mixers, amplifiers, and filters. The MHz Oscillator frequency is applied to mixer Q2 through buffer Q1. Q2 subtracts the MHz Oscillator frequency and its error from the appropriate MHz spectrum frequency, resulting in a product of approximately 7.753 MHz with reversed error. (Refer to sections 4.3.1 and 4.3.2 for a discussion of error cancelling. Refer to table 4.1 for particular oscillator and spectrum frequencies.) This product passes through FL1 and is amplified by Q3. All other frequencies generated are attenuated to a negligible level. The 100 kHz Oscillator frequency is applied to mixer Q7 through buffer Q6. In Q7, the 100 kHz Oscillator frequency and its error is subtracted from the appropriate 100 kHz spectrum frequency to produce a frequency of approximately 21.953 MHz with a reversed error. This product is passed through FL4 to mixer Q8. In Q8, the 7.753 MHz frequency and reversed MHz Oscillator error from Q3 is subtracted from the 21.953 MHz frequency and reversed 100 kHz Oscillator error to produce a new frequency of approximately 14.2 MHz with the reversed 100 kHz Oscillator error and the twice reversed (normal) MHz Oscillator error. Q4 adds the 10 kHz and 1 kHz Oscillator frequencies and their errors to produce a new frequency of approximately 2.595 MHz containing the two errors. FL2 passes this product to Q9. In Q9, the 2.595 MHz (plus error) frequency is subtracted from the 14.2 MHz frequency with the error of the MHz Oscillator and the reversed error of the 100 kHz Oscillator to produce a new frequency of approximately 11.6 MHz with the error of the MHz Oscillator and the reversed errors of the 100, 10 and 1 kHz Oscillators. FL3 passes this product to Q5, which amplifies it and applies it to the Translator assembly.

In order to simplify the mixing and error reversal process, let us consider it algebraically. Let the appropriate MHz, 100 kHz, 10 kHz, and 1 kHz spectrum frequencies equal S_4 , S_3 , S_2 , and S_1 , respectively. Let the appropriate MHz, 100 kHz, 10 kHz, and 1 kHz Oscillator frequencies equal F_4 , F_3 , F_2 , and F_1 , respectively. Let the MHz, 100 kHz, 10 kHz, and 1 kHz Oscillator errors equal E_4 , E_3 , E_2 , and E_1 , respectively.

The product of Q2 will be $S_4 - F_4 - E_4$. The product of Q7 will be $S_3 - F_3 - E_3$. Subtracting $S_4 - F_4 - E_4$ from

$S_3-F_3-E_3$ in Q8, we get $S_3-S_4-F_3+F_4-E_3+E_4$ as the product. Note that error E_4 has again been reversed.

The product of Q4 will be $F_2+E_2+F_1+E_1$. Subtracting this product from $S_3-S_4-F_3+F_4-E_3+E_4$ in Q9, we arrive at a final mixer product of $S_3-S_4-F_3+F_4-E_3+E_4-F_2-E_2-F_1-E_1$.

Referring to table 4.1, substituting the corresponding frequencies listed for S (spectrum) and F (oscillator), the resultant frequency will be approximately $11.6 \text{ MHz}+E_4-E_3-E_2-E_1$. The resulting errors are cancelled in the Translator and the SSB detector.

4.7.12 455 kHz ERROR MIXER ASSEMBLY.

The 455 kHz Error Mixer assembly consists of mixers, amplifiers, filters and an oscillator. Q1 subtracts the appropriate 10 kHz spectrum frequency from the 10 kHz Oscillator frequency producing a new frequency of approximately 646.5 kHz, containing the 10 kHz Oscillator error. This product is passed through FL1 and amplified by Q2. In Q3, the 1 kHz Oscillator frequency and error is subtracted from the appropriate 1 kHz spectrum frequency, producing an output frequency of approximately 1,101.5 kHz containing the reversed error from the 1 kHz Oscillator. Q4 subtracts the 646.5 kHz frequency and the 10 kHz Oscillator error from the 1,101.5 kHz frequency and the reversed 1 kHz Oscillator error, resulting in a new frequency of approximately 455 kHz, containing the reversed errors of the 10 kHz and 1 kHz Oscillators. The output is amplified by Q5 and applied to the SSB modulator/detector. The 10 kHz and 1 kHz Oscillator errors are cancelled in the SSB detector on receive and in the translator on transmit. When the VFO is used, it is no longer possible to derive the 1,101.5 kHz frequency for Q4 from the 1 kHz Oscillator and spectrum in Q3. The 1,101.5 kHz Oscillator, Q6 is employed to generate this frequency, and mixer Q3 is disabled when the VFO is used. To accomplish this change, operating voltage is applied to Q6, and Q3 is biased to cutoff.

Q7 is a carrier control amplifier, which regulates the level of the 455 kHz carrier reinsertion to the Translator assembly in AM transmit operation. A

DC automatic carrier control signal from the ACC assembly regulates the amplification of Q7.

4.7.13 DC POWER MODULES.

The dc power modules, RF-303 and RF-304 consist of a saturable transformer and two transistor switches. The saturable transformer T1 is the heart of the system. Transistors Q1 and Q2 act as switches, one being "on" while the other is "off". Starting oscillation of the circuit depends upon the unbalance existing between the apparently identical circuits of transistors Q1 and Q2. This unbalance is due to both external circuitry and transistor unbalance, and causes more current to flow in the circuit associated with one transistor than that associated with the other. Assume that transistor Q1 is conducting and that transistor Q2 is essentially cut off, for the following discussion. This effectively connects the supply voltage across the top half of the primary winding of transformer T1, and induces a voltage in all windings. At the instant that transistor Q2 starts to conduct, the voltages and currents assume a maximum level. This condition continues to exist until the core of transformer T1 saturates, thereby causing the rate of flux change to drop to zero. During the same time intervals, the initially induced voltages first decrease in value and then quickly fall to zero. This first decreases and then removes the base drive to transistor Q1. The current in the top half of transformer T1 now begins to decrease, which causes the flux to build up in the opposite direction. Voltages of opposite polarity to that which previously existed are induced in the transformer windings, and transistor Q2 starts to conduct with transistor Q1 being driven further into cutoff. The conduction of transistor Q2 continues until opposite core saturation is reached, at which time the cycle is ready for repetition.

The transistors, operating from cutoff to saturation, provide a square wave output. The output frequency and amplitude are primarily determined by the number of turns in the primary winding of the transformer, the supply voltage, and the saturation flux of the transformer core. The dc power modules have been designed for a frequency of approximately 60 Hz for use with power supply transformer T1.

SECTION 5

MAINTENANCE

5.1 GENERAL.

This section contains procedures for routine maintenance and overall performance tests. The length of intervals between times at which periodic preventive maintenance should be performed depends on the amount of usage and the environmental conditions and is, therefore, left to the discretion of the user. It should be obvious, however, that regular preventive maintenance increases the reliability and service life of the equipment.

If malfunctions or degraded performance are evident, and their corrections are not within the scope of this section, the problems should be referred to someone qualified to perform advanced servicing covered in the SERVICING section of this manual. It is helpful to record performance measurements and other information discovered during routine maintenance. The notes can be referred to at subsequent maintenance or servicing times.

5.2 FUSE REPLACEMENT.

CAUTION

Under no circumstances should fuses be used with ratings above those specified. If fuses blow repeatedly, a technician should check the unit and the primary power source. Frequently, power line transients cause fuses to blow. The correct remedy for this problem is to install a line regulator, not a heavier rated fuse.

Three fuses are used in the transceiver. The AC and DC prime power fuses are located on the rear panel. The DC fuse is used only when the transceiver is equipped with a DC Power Module. For 115 VAC, the fuse should be a 4 AMP, type AGC (RF # F-0014). For 230 VAC, the fuse should be a 3 AMP, type AGC (RF # F-0013). For 13.5 VDC, use a 25 AMP, AGC fuse (RF # F-0019). For 26.0 VDC, use a 15 AMP, AGC fuse (RF # F-0018). A 1-1/2

AMP, AGC (RF # F-0011) fuse is mounted in clips on the side of the relay bracket under the chassis. This fuse protects the +12 VDC power supply against overloads in the transceiver's transistor circuitry.

5.3 VISUAL INSPECTION.

Periodically, the cover should be removed from the chassis, and the chassis should be visually inspected. Loose hardware should be tightened. Accumulated dirt should be removed. Connections to the rear panel should be inspected for damage. The air filter should be checked and cleaned if necessary. Refer to section 3.6 for filter cleaning procedure.

5.4 LUBRICATION.

Most of the moving parts in the transceiver normally do not need lubrication. In particular, the parts which don't need lubrication are the metal and nylon bushings and couplings, the gear train and chain on the VFO capacitor drive, switches, and reduction drives. The 1 kHz frequency control clutch and the PA variable inductor, however, should be lubricated with a very light coating of "Molykote G" made by Alpha Molykote Corp., Stanford, Connecticut. The PA inductor should be lubricated at the shaft bearings and the rod which the roller slides on. The turns of the coil should be wiped clean. They should not be lubricated.

5.5 TEST EQUIPMENT.

The following test equipment is suggested for maintenance:

Tube Tester

Vacuum Tube Voltmeter—H.P. 410-C or equivalent.

AC Vacuum Tube Voltmeter—Ballantine 314A, H.P. 400-D, or equivalent.

52 ohm, 200 watt dummy load.



RF Signal Generator with attenuator—H.P. 606-A or equivalent.

A general coverage communications receiver or another RF-301 Transceiver if available.

5.6 TUBE REPLACEMENT.

A reliable tube tester should be used to check the performance of the RF amplifier and PA tubes. Weak or defective tubes should be replaced.

5.7 PA BIAS ADJUSTMENT.

After the PA tubes have aged considerably or have been replaced, the PA bias level should be adjusted for proper tube idling current. When adjusting the bias level, press the meter switch S-7 on the underside of the transceiver. Pressing S-7 allows the meter to indicate relative cathode current to the PA stage. Adjust PA bias level control R-4 on the relay bracket, for a reading of "S9" on the meter while the transceiver is keyed in USB or LSB mode. Be sure an antenna or dummy load is connected to the transceiver (see fig. 5.1).

Do not speak into microphone while making the bias adjustment.

NOTE

The PA bias level should be adjusted using DC primary power if the transceiver will be operated on DC. If the transceiver will be operated on both AC and DC, the idling current will change when changing over from AC to DC. The PA bias level should be set such that the mean idling current indication would be "S9" on the meter. In other words, it should be set so that it would read slightly to one side of "S9" on AC and slightly to the other side on DC.

5.8 PERFORMANCE TESTS.

To determine if the transceiver is operating as it should, conduct the over-all performance tests in the following sections. Comparing information obtained in these procedures with information recorded during prior performance tests will indicate if the performance is degraded. Problems should be referred to qualified servicing personnel.

5.8.1 RECEIVER PROTECTOR TEST.

To determine if the receiver protector assembly operating perform the procedures outlined below

- a. Energize the transceiver and tune to receive at 2.0 MHz. Set FUNCTION switch at USB.
- b. Rotate TRANSMIT AUDIO control full counterclockwise.
- c. Connect an RF signal generator, such as a HI 606A, to the ANTENNA connector on the rear panel using a coaxial cable. Set the RF signal generator for 1 μ volt output at 2 MHz.

CAUTION

Do not key transceiver with RF signal generator connected to ANTENNA connector.

- d. While monitoring the received RF signal generator signal rotate the TRANSMIT AUDIO control fully clockwise to the TUNE detent. Observe that the received signal is no longer present.
- e. Set the FUNCTION switch at OFF. Disconnect the RF signal generator.

5.8.2 RECEIVER SENSITIVITY AND AGC CHARACTERISTICS.

- a. Set up transceiver to receive USB or LSB at a frequency as discussed in OPERATING section.
- b. Connect signal generator to antenna connector in place of antenna or coupler.

Connect AC VTVM between pins 4 and 6 of J REMOTE connector.

CAUTION

Do not key transmitter while signal generator is connected to transceiver.

- c. Turn RF GAIN control to maximum clockwise position.



d. Adjust signal generator frequency for maximum audio output reading on VTVM with signal generator set for 0.5 μ V output. Record reading.

e. De-tune signal generator and note noise output reading on VTVM.

The ratio of the first reading to the second is the (S + N)/N ratio and should be no less than 3.2 or 10 dB.

Tune generator back on frequency.

f. Turn generator output up to 0.2 volt. Record VTVM reading.

The ratio of the step f reading to the step d reading should be less than 10/1 or 20 dB.

5.8.3 TRANSMITTER OUTPUT AND MODULATION.

a. Connect 200 watt, 52 ohm dummy load and H.P. 410-C VTVM RF probe to antenna connector.

b. Tune transmitter for 100 watts CW output at 14.5 MHz as discussed in OPERATING section.

c. The transceiver meter should read 100 watts and the VTVM should read 65-75 volts. A minimum of 100 watts output should be available from the transceiver.

d. With dummy load and VTVM still connected, change the FUNCTION switch to AM and transmit a voice signal using microphone. Listen to audio quality on a receiver. Audio should be clear with no hum. The transceiver output meter should deflect when speaking. The RF output should read between 30-45 volts (of carrier) on the VTVM when not speaking.

5.8.4 FREQUENCY ACCURACY.

The frequency accuracy can best be checked by receiving the AM time signals from a frequency-standard-station such as WWV, WWVH, or CHU. When the transceiver is tuned to their known frequency on LSB or USB, a zero-beat or near zero-beat should occur.

5.9 POWER SUPPLY VOLTAGE MEASUREMENTS.

Table 5.1 lists the approximate voltages which can be measured at the outputs of the various power supplies during receive operation. Figure 5.1 identifies the points to which the VTVM probe can be attached for these measurements. Chassis ground is used as a reference for these voltages. Any deviation more than 15% from the expected readings should be investigated.

Table 5.1 – Power Supply Voltage Measurements

TEST POINT	VTVM SET FOR	EXPECTED READING (USB receive)
A (C1)	+DC	890 VDC
B (C86)	+DC AC	235 VDC 21 VAC (RIPPLE)
C (C3)	+DC AC	205 VDC 200 MVAC (RIPPLE)
D	AC	6.3 VAC
E	-DC	-55 VDC
F (C5, -)	-DC	-82 VDC
G (C6, -)	-DC	-75 VDC
H (C84, +)	+DC AC	14.6 VDC 220 MVAC
I (C85, +)	+DC AC	14.2 VDC less than 40 MVAC

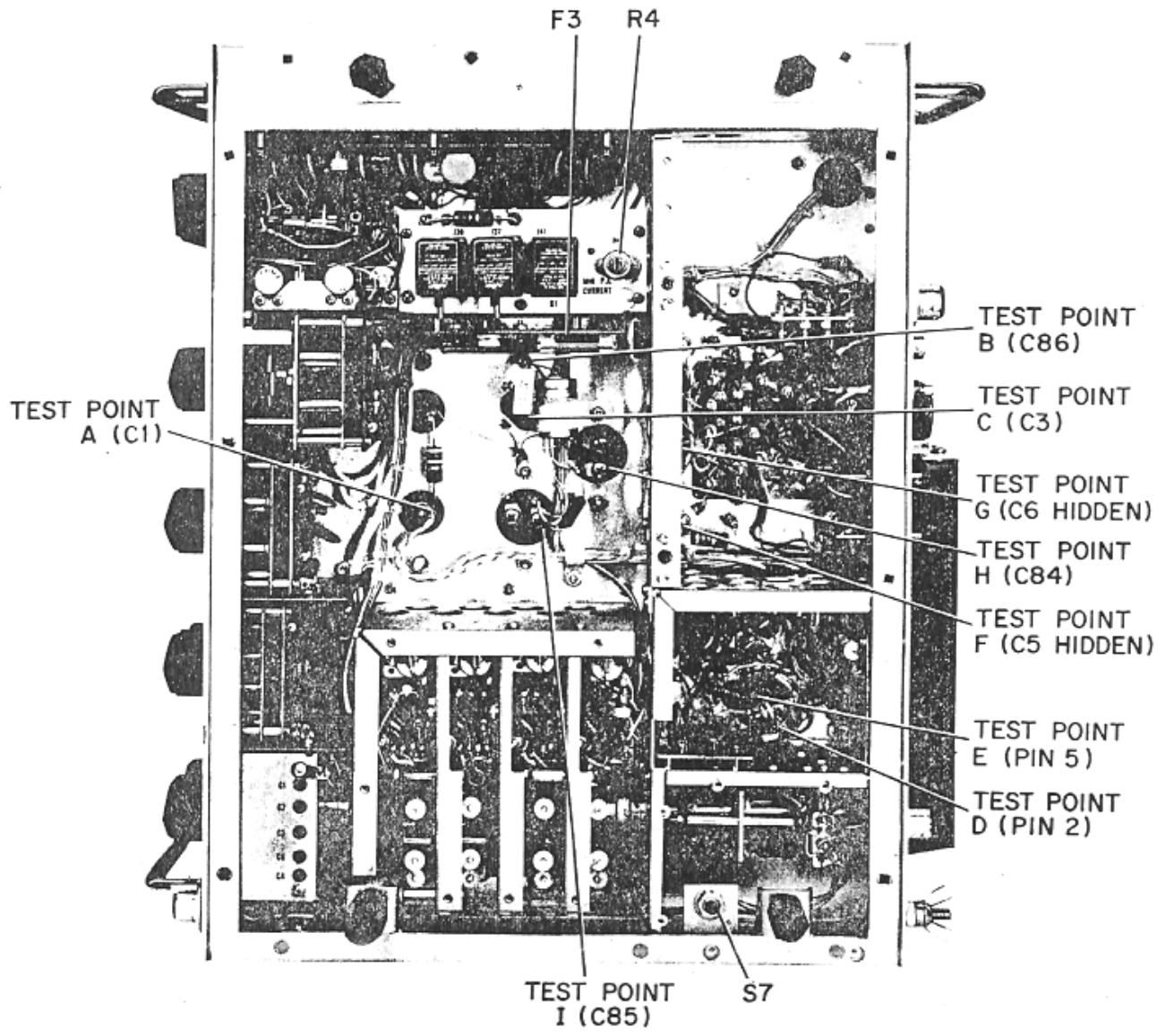

Figure 5.1 — Power Supply Voltage Test Points.



SECTION 6

SERVICING

6.1 GENERAL.

The SERVICING section of this manual is intended for use by persons qualified to perform advanced troubleshooting and repair for this type of equipment. It covers procedures for isolating the trouble to a functional section of the transceiver and locating and correcting faults within the functional section. The functional sections are, for the most part, built in separate assemblies, so that, once a particular fault is narrowed down, only one assembly will be involved in the repair. This helps to simplify the troubleshooting procedure.

It is assumed that, prior to servicing, the person using information in this section has a thorough knowledge of the PRINCIPLES OF OPERATION as discussed in SECTION 4.

6.2 POWER SUPPLIES.

It is assumed in this section that the problem lies in the signal circuitry and that the power supplies are functioning properly. Refer to paragraph 5.9 for the power supply voltage testing procedure. Should the power supplies be faulty, they must be repaired before continuing in this section. If power supply failure is due to an overload in the signal circuitry, it should be determined which assembly is at fault, and its repairs should be made before continuing. The SERVICING section will not include detailed power supply troubleshooting. These faults can be located with the aid of the schematic diagrams.

6.3 TEST EQUIPMENT REQUIRED.

The following test equipment is suggested for servicing the RF-301 Transceiver:

RF VTVM – Boonton Model 91CA or equivalent.

200 watt, 52 ohm dummy load.

RF Signal Generator – H.P. 606-A or equivalent.

AC-DC VTVM – H.P. 410-C or equivalent.

Audio VTVM – Ballantine 314A, H.P. 400-D, or equivalent.

Heterodyne Voltmeter – Bruel & Kjaer Type 2005.

Oscilloscope – Tektronix Model 515 or equivalent.

Frequency Counter – H.P. 5242-L or equivalent.

DC Power Supply – H.P. 721-A or equivalent.

Extender Kit – RF-318

6.4 PRINTED CIRCUIT BOARD REPAIRS.

These general rules should be observed when replacing components on printed circuit boards:

- a. Do not apply high heats for excessive periods.
- b. Use heat sinks on semiconductor leads.

c. Use a tooth pick or wooden splinter to clean melted solder from holes.

- d. Do not force leads of components into holes.

6.5 TEST POINTS.

During the troubleshooting procedures which follow, it will be necessary to connect test instruments to various points in the signal circuitry. The individual circuit boards are identified in figures 6.1 through 6.3.

Refer to table 1.2 for assembly reference number information. Each assembly is illustrated by a component layout diagram next to its schematic diagram in section 8. These diagrams show the component and printed wiring (phantom view) layouts and interconnections of each assembly, as seen from the component side. Points to which connections are called for are identified in these diagrams. Voltages are measured with reference to ground.

6.6 LOCATING THE FAULTY FUNCTIONAL SECTION.

6.6.1 SYMPTOM RECOGNITION.

Careful consideration of the symptoms evident during a failure is the most important step in

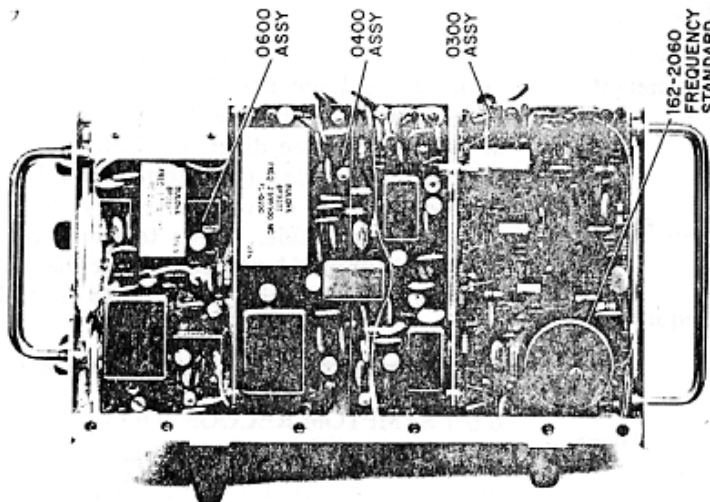

REFERENCE NUMBER	NOMENCLATURE
03	Divider/Spectrum Generator
04	11.6 MHz Error Mixer
06	Translator

Figure 6.1 — Assemblies on Right-Hand Side of Chassis

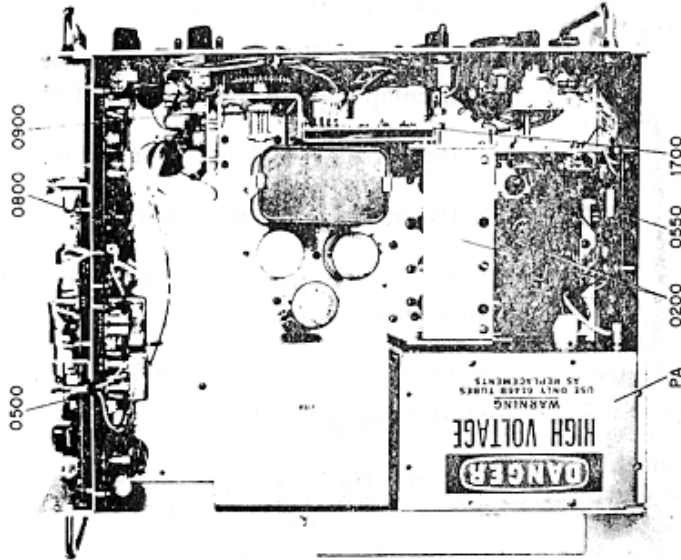

REFERENCE NUMBER	NOMENCLATURE
PA	Power Amplifier
02	RF Amplifier
05	455 kHz Error Mixer
055	Receiver Protector
08	Audio/Modulator
09	VFO
17	Audio Amplifier

Figure 6.2 — Assemblies on Top of Chassis

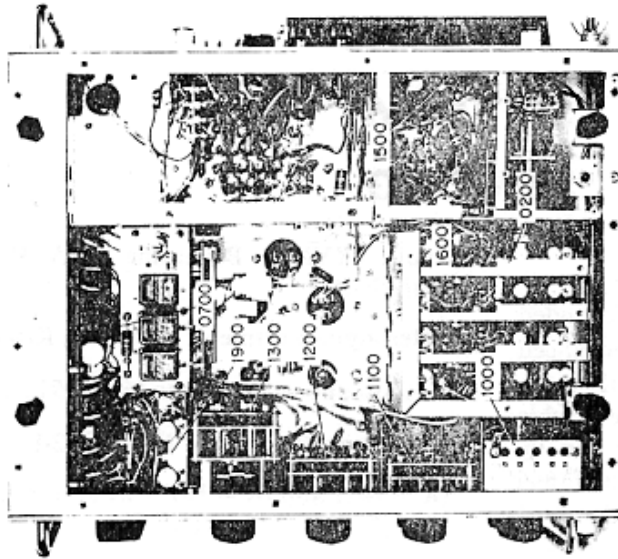

REFERENCE NUMBER	NOMENCLATURE
02	RF Amplifier
07	IF Amplifier
10	MHz Oscillator
11	100 kHz Oscillator
12	10 kHz Oscillator
13	1 kHz Oscillator
15	ALC
16	ACC
17	Audio Amplifier
19	IF Filters

Figure 6.3 — Assemblies on Underside of Chassis

troubleshooting. Random checking of circuits, with no orderly pattern or purpose, usually does not help in troubleshooting complex equipment. An attempt to elaborate on the symptoms quite often is a key to the areas to check first. Transmitter failure (receiver operable) or vice versa eliminates assemblies common to both transmit and receive modes such as the RF Amplifier, Translator, Error Mixers, Divider/Spectrum Generator, and Crystal Oscillators, but not their associated signal and power switching circuits. If one of these common mode assemblies operates in one mode but not the other, the fault probably lies in the T/R or R/T line voltages, or switching diodes and/or relays for that assembly.

Simultaneous failure to transmit and receive indicates defects in the circuits common to both transmit and receive modes.

Various frequencies and modes should be checked, and the operating controls and meter should be checked to determine which functions and frequencies may be affected.

Determine whether the transceiver is inoperative in transmit and/or receive. If the unit will not transmit but will receive, perform the signal tracing procedure in paragraph 6.6.2. If the unit will transmit but not receive, perform steps in paragraph 6.6.3. If the unit will neither transmit or receive, perform steps in paragraph 6.6.4.

If the signal voltage measurements taken are considerably lower than they should be, the problem most likely involves a stage with low gain. Care must be taken, during measurements, to determine that the readings are actually signal readings and not oscillations or injections from oscillators.

CAUTION

The miniature coaxial connectors are easily damaged by abuse. They can be a possible trouble point. When a test indicates that a signal is not present at an input or output cable, check the connector to determine if it is making a good connection before suspecting that an assembly is at fault.

A few problems can be identified directly by the symptoms discovered when operating the trans-

ceiver. These are listed in table 6.0. If one of these problems occurs, proceed directly to the test procedure for that particular assembly to verify the fault.

6.6.2 TRANSMITTER FAILURE.

a. Remove top and bottom covers from transceiver. Remove ALC assembly (paragraph 6.18.4).

b. Connect dummy load to ANTENNA connector J4.

c. Apply power, and set transmitter for CW output at 2.555 MHz with TRANSMIT AUDIO control set at mid point. Key the transceiver. CW side-tone should be present at the speaker. Unkey transmitter and tune PRESELECTOR control for maximum noise output from speaker. Perform steps (d) through (g) with transmitter keyed. (Leave transmitter keyed only as long as is necessary for each step since fan is disconnected.)

d. Disconnect P11 at translator and connect P11 to signal generator set for 400 MV output at 2.555 MHz. Tune PRESELECTOR and PA TUNE controls for maximum indication on transceiver output 100W watts or more, proceed to step g.

e. Connect RF VTVM to pin 11 of K1 located on the RF amplifier assembly (refer to fig. 6.4). If indication is 400 MV, proceed to step f. If no indication is present, check K1 and the coaxial cable connected from K1 pin 9 to J50.

f. Connect RF VTVM to output of RF Amplifier at terminal E159 (fig. 8.1). Slowly tune PRESELECTOR for peak indication of 35 volts or more on VTVM. If no or low output is present at E159, proceed to paragraph 6.9. If output is normal, proceed to paragraph 6.8.

g. Unplug P10 at translator assembly, and connect it to RF VTVM. Input signal level at P10 from upper sideband filter should be from 15 to 30 MV. A 10 MV signal will result in an RF output from PA section of at least 50 watts. If normal signal is present, problem is probably in the Translator T/R or R/T diode switching circuits. Check the voltages at Translator R/T terminal E62 (0 VDC) and T/R terminal E63 (fig. 8.9) (12 VDC). If no or low signal is present at P10, problem is in stages preceding Translator. Reconnect P10.

Table 6.0 — Fault Location Chart

FAULT	SUGGESTED TROUBLE POINT
Completely dead	Prime power fuse
No LSB	LSB filter
No USB or CW	USB filter
No AM receive	AM detector
No AM carrier	Carrier control amplifier
Operate only on AM receive	SSB modulator/detector
No CW transmit or sidetone	CW oscillator
Failure on certain frequencies	Associated crystal oscillator
No vernier tuning	VFO or 1.1015 MHz oscillator
Receiver overloaded, no S-meter reading	AGC circuits
Transmitter output distorted on SSB	ALC circuits
Transmitter output distorted on AM	ACC circuits
Transmitter output ok, no meter reading	Output detector circuits

h. Unplug P22 at IF Amplifier (fig. 8.11) and connect it to RF VTVM. Input signal at P22 from Audio/Modulator should be at least 15 MV with TRANSMIT AUDIO control fully clockwise (not in TUNE position). If this signal is present, problem probably is in the upper sideband filter. If Amplifier transmit section, or associated T/R or R/T switching circuits. If no or low signal is present, problem is probably in Audio/Modulator assembly or TRANSMIT AUDIO control. Reconnect P22.

i. Install ALC assembly (paragraph 6.18.4).

6.6.3 RECEIVER FAILURE.

a. Remove top and bottom covers from transmitter. Connect dummy load to ANTENNA connector J4.

b. Apply power and tune transmitter for 100W CW output at 2.555 MHz.

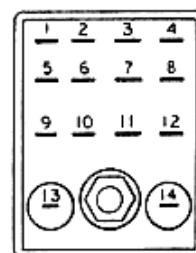

Figure 6.4 — Relay Terminals

c. Disconnect microphone or CW key from transmitter. Connect a signal generator set for a 10 MV, 2.555 MHz signal to ANTENNA connector J4 in place of dummy load. Set RF GAIN fully clockwise.

d. Unplug P11 at Translator, and connect it to RF VTVM. Vary output frequency of signal generator above and below 2.555 MHz while observing RF Amplifier output indication on RF VTVM. A peak indication of at least 50 MV should be obtained. If not, problem is in antenna transfer relay K4, Receiver Protector assembly, RF Amplifier transfer relay K1, or cabling. If this signal is present, problem is in receive circuits following RF Amplifier. Reconnect P11.

e. Connect RF VTVM to E167 on IF Amplifier and short pin E on O260 Board to ground (fig. 8.1). With signal generator set for 1 MV output, very slowly sweep its output frequency above and below 2.555 MHz while observing Translator output on RF VTVM. A peak indication of about 50 MV should be obtained. If not, problem probably is in Translator T/R or R/T diode switching circuits. Check T/R and R/T voltages at Translator terminals E62 (12 VDC) and E63 (0 VDC). If this signal is present, problem is in receive circuits following Translator.

f. Set signal generator for 50 MV output at 455 kHz, and reconnect it to E167 on IF Amplifier. Unplug P22 at IF Amplifier, and connect J22 to RF VTVM. Vary output frequency of signal generator above and below 455 kHz while observing IF Amplifier output on RF VTVM. A peak indication of about 1000 MV \pm 200 MV should be obtained. If it is not, problem is in IF Amplifier receiver circuits or T/R or R/T switching circuits. If normal signal levels are present, problem is in receive circuits following IF Amplifier. If signal levels are excessive (audio distortion present, with P22 connected) and S-meter does not indicate with pin E on O260



Board ungrounded; IF Amplifier AGC circuits may be defective. If excessive voltage does not decrease as signal generator is detuned, IF Amplifier receive stages may be oscillating. Reconnect P22.

g. Connect Audio VTVM to terminals 4 and 6 of J3 REMOTE connector on rear of chassis. Meter should read at least 1 volt of audio output when signal generator is tuned to about 455 kHz. If audio is available in all modes, but there is no speaker output with speaker turned on and RECEIVE AUDIO gain control turned up, problem probably lies in Audio AMPLIFIER assembly, RECEIVE AUDIO control, or speaker. If audio is available only in AM mode, problem probably lies in SSB detector, or lack of 455 kHz injection. If output is available only in SSB, problem lies in AM detector. If no audio is available in any mode, problem probably is in receive audio stages in Audio/Modulator assembly.

6.6.4 TRANSMITTER AND RECEIVER FAILURE.

Simultaneous transmitter and receive failure usually indicates the failure of a common mode assembly such as the RF Amplifier, Translator, Sideband Filters and/or selection circuits, Audio/Modulator, Crystal Oscillators, Error Mixers, Divider/Spectrum Generator, or Frequency Standard.

The Translator is the mixing point of signals from the RF or IF Amplifiers and of injection voltages from the 11.6 MHz Error Mixer, and MHz and 100 kHz Oscillators. Tracing an abnormal signal back to its source or a normal output to the antenna load in the transmit mode is the basis of the following troubleshooting procedures for common mode failures.

a. Connect dummy load to ANTENNA connector J4. Set transceiver controls for CW transmission at 2.555 MHz with TRANSMIT AUDIO control at midpoint. Key transmitter while performing the following procedures. (Leave transmitter keyed for only as long as is necessary for each step since fan is disconnected).

b. Disconnect P11 at translator, and connect P11 to signal generator set for 400 MV output at 2.555 MHz. Tune PRESELECTOR and PA TUNE controls for maximum indication on transceiver Output meter. If no output, proceed to step c. If output is 50 watts or more, proceed to step e.

c. Connect RF VTVM to pin 11 of K1 located in the rf amplifier assembly (refer to fig. 6.4). If indication is at least 400 MV, proceed to step d. If no indication is present, check K1 and coaxial cable connected from K1 pin 9 to J50.

d. Connect RF VTVM to output of RF Amplifier at terminal E159 (fig. 8.1). Slowly tune PRESELECTOR for peak indication of 35 volts or more on VTVM. If no or low output is present at E159, proceed to paragraph 6.9. If output is normal, check antenna transfer relay K4.

e. Disconnect following coaxial connectors at Translator and connect them, in sequence to an RF VTVM. Voltage indications should be as shown:

1.) P7 (100 kHz Oscillator injection voltage) = 150 - 300 MV

2.) P8 (MHz Oscillator injection voltage) = 250 - 650 MV

3.) P9 (11.6 MHz Error Mixer injection voltage) = 125 - 200 MV

4.) P10 (455 kHz signal from upper sideband filter) = 15 to 50 MV

If either Oscillator injection voltage is abnormal, check that Oscillator circuit. If only the 11.6 MHz Error Mixer injection voltage is abnormal, proceed with step f below. If only the 455 kHz signal from the IF Amplifier (via the upper sideband filter) is abnormal, proceed with step g below. If both the 11.6 MHz Error Mixer and 455 kHz input voltages are abnormal, proceed with step j below.

f. Low or lack of mixer injection voltage at P9 indicates an abnormal input to, or a defective component in the 11.6 MHz Error Mixer. Disconnect, and leave disconnected, the following coaxial connectors at the Error Mixer, and connect them, in sequence, to the RF VTVM. Voltage indications should be as shown.

1.) P35 (1 kHz Oscillator injection voltage) = 70 - 220 MV

2.) P42 (10 kHz Oscillator injection voltage) = 5 to 9 MV



3.) P36 (MHz Spectrum injection voltage) = 1 - 1.5V

4.) P34 (MHz Oscillator injection voltage) = 20 - 70 MV

5.) P33 (100 kHz Oscillator injection voltage) = 30 to 65 MV

Connect RF VTVM to terminal E165 (fig. 8.5) on 11.6 MHz Error Mixer. Indicated 100 kHz Spectrum injection voltage should be between 50 and 80 MV. Reconnect P33 through P36 and P42.

If any of the Oscillator injection voltages are abnormal, check that Oscillator circuit. If either Spectrum injection voltage is abnormal check the associated circuits in the Divider/Spectrum Generator.

g. Low or lack of 455 kHz input signal to the Translator at P10 in CW transmit mode indicates a defective upper sideband filter or filter selection circuit, or an abnormal input to or defective component in the IF Amplifier. Connect RF VTVM to terminal E167 on IF Amplifier. Indicated 455 kHz IF Amplifier output signal level should be at least 50 MV. If this voltage is normal, the problem is in the upper sideband filter or selection circuits. If the voltage is abnormal disconnect lead from E167 and check it for shorts. If none, disconnect coaxial connector P22 from the IF Amplifier, and reconnect it to the RF VTVM. Indicated 455 kHz output signal from the Audio/Modulator should be at least 10 MV. If this voltage is normal, the problem is in the IF Amplifier. If the 455 kHz output voltage is abnormal, the problem is probably in the Audio/Modulator, an abnormal input to, or component in the 455 kHz Error Mixer. To determine which, proceed with step h.

h. Disconnect coaxial connector P17 and connect RF VTVM to J17 on 455 kHz Error Mixer (fig. 8.7). Indicated 455 kHz injection output voltage should be between 200 and 300 MV. If this voltage is normal, the Audio/Modulator or coaxial cable between the Audio/Modulator and 455 kHz Error Mixer is probable defective. If the voltage at J17 is abnormal, proceed with step i.

i. Low or lack of 455 kHz output (except in AM receive) at J17 indicates an abnormal input to or defective component in the 455 kHz Error

Mixer. Disconnect following coaxial connector at the Error Mixer, and connect them in sequence to the RF VTVM. Voltage indications should be as shown.

1.) P12 (1 kHz Oscillator injection voltage) = about 50 MV

2.) P13 (10 kHz Oscillator injection voltage) = about 150 to 300 MV

3.) P14 (10 kHz Spectrum injection voltage) = 30 to 50 MV

4.) E91 (1 kHz Spectrum injection voltage) = 5.5 to 7.5 MV (Check E91 on Divider/Spectrum Generator and leave P15 connected to J15.)

If either Oscillator voltage is abnormal, check that Oscillator. If neither Spectrum voltage is abnormal, check the associated circuits in the Divider/Spectrum Generator. If all inputs are normal, the problem is in the 455 kHz Error Mixer.

j. Low or lack of Error Mixer injection voltages at the translator at both P9 and P10, with normal MHz and 100 kHz Oscillator injection voltages present, indicates a defect in either the 10 kHz, 1 kHz, or VFO Oscillators which have outputs to both Error Mixers, or a defect in the Divider/Spectrum Generator, or Frequency Standard, affecting one or more of the two Spectrum Generator outputs to each Error Mixer.

k. Disconnect signal generator and reconnect P11 to J11.

6.7 LOCATING THE PROBLEM WITHIN THE FUNCTIONAL SECTION.

The remaining major paragraphs of this section contain detailed test, alignment, and removal-installation procedures for each assembly.

6.7.1 TEST PROCEDURES.

Once the problem has been narrowed down to one functional section or assembly, a stage by stage check of stage inputs and outputs in logical order should isolate the problem to one or more stages.

When checking individual stages for signals, assume that the stages, if faulty, are either not operating or

are operating at reduced performance. The following tests will be conducted on the basis of presence or absence of normal signal. Normal signal levels for each stage of an assembly are given in the voltage table for each assembly. Since these signal levels may vary somewhat from set to set and according to many conditions, only by comparing signal levels from stage to stage, during progress in the procedure, can it be determined if a stage is operating at reduced performance.

The procedures will also involve checking for mixer injections, since their absence will indicate that the problem lies in the circuits responsible for the injections and not in the mixer where the problem was discovered. Refer to the test procedures for such related assemblies, when necessary. In checking mixers, care is required to determine that the level measured is of the desired signal, since there are injections from other assemblies involved which will also show up at the test points.

It is assumed that the operating voltages and proper control voltages are applied to the stages being tested. If, however, it is found that none of the stages of an assembly are operating, the dc voltages should be checked.

During performance of the following test procedures, refer to the respective schematic and layout diagrams in SECTION 8 and the signal block diagram, figure 4.6.

CAUTION

Care must be exercised, when checking transistor circuitry, not to accidentally short the leads to the case or surrounding circuitry. This might destroy the transistor.

The component side of the printed circuit board assemblies is, in most cases, sufficiently accessible to permit testing of the individual stages of an assembly with it installed in the transceiver. However, portions of the 455 kHz Error Mixer, IF Amplifier, and Audio/Modulator assemblies are inconvenient to reach, and complete testing of these assemblies requires their removal. The use of coaxial and multiconductor extension cables (RF-318) for connection of RF, control, and power supply voltages

to these assemblies after their removal from the transceiver will facilitate testing them.

Because of the complex interconnection of its three sub-assemblies, as well as the relatively complex removal, disassembly, assembly, installation, and mechanical alignment procedures involved, the RF Amplifier assembly is tested as a unit and in place in the transceiver.

Portions of the MHz and 100 kHz Crystal Oscillator assemblies are also inconvenient to reach for testing; however, these portions normally become accessible when the assembly is detached from the front panel with its wiring (except ground leads) left connected.

The Audio Amplifier is inaccessible when mounted in the chassis, but may be removed and reconnected to its cable for testing without being reinstalled.

6.7.2 VOLTAGE AND RESISTANCE MEASUREMENTS.

Tables 6.1 through 6.17, included with the procedures for their respective assemblies, contain DC and AC voltage and certain resistance measurements for the vacuum tubes and transistors used in the RF-301 transceiver. The waveforms in figures 6.6 through 6.21 present more detailed AC voltage information for the Divider/Spectrum Generator than VTVM readings, and with the exception of the RF output level of each of the spectrum generators, AC VTVM readings are not included in the table for this assembly. Table 6.18 contains waveforms for the 12 VDC and 24 VDC Power Modules. The tubes and transistors of each assembly of the RF-301 transceiver are listed in the tables identified by the assembly number, preceded by the number 6. Unless otherwise specified in the Notes column, voltage measurements were made with the test equipment listed below, with the transceiver tuned to 2.555 MHz in the CW receive mode, with RF Gain set fully clockwise, with SPEAKER switch on, and with 115 volt 60 CPS power input. If supply and other voltage measurements are made in the transmit mode when it is not specified, somewhat lower readings will result. Resistance readings are given only for vacuum tube stages. All readings are typical, but they may vary from set to set. Such factors as line voltage, drive level in transmit, audio level in receive, and input signal in receive may affect readings. Spaces marked



“X” are readings that have been omitted because of insignificance.

Test equipment used is as follows:

RF voltage measurements -- Boonton 91C VTVM

Low level AC voltage measurements -- Ballentine 314C VTVM

Other AC-DC voltage measurements -- HP 410C VTVM

Resistance measurements -- HP 410C VTVM

Waveforms -- Tektronix 515 Oscilloscope

Tube extenders, both 7 pin and 9 pin.

6.7.3 ALIGNMENT.

The alignment procedures describe the electrical alignment of the various assemblies in the transceiver. The set-up conditions are specified in the procedures.

In most cases, the alignment will already be very close to being correct, and only touchup is required. In other cases, where a stage has been repaired, only a few of the alignment components need be adjusted. Random adjustments are not advisable. Careful thought should be given to determining which adjustments are actually necessary. These adjustments should then be done carefully according to the alignment procedures.

6.7.4 ASSEMBLY REMOVAL AND INSTALLATION.

The removal -- installation procedures for each assembly include necessary disassembly and assembly instructions, and mechanical alignment required during assembly and installation.

Reference to some location on the transceiver (such as upper, top, lower, etc.) are made with respect to its normal, upright position, regardless of the position it may be in during the performance of the particular procedure involved. Screws designated as securing PC boards or other assemblies in place, are ordinarily used with other common hardware items such as lock and flat washers, etc.

Requirements for such items can normally be determined by inspection and are not given.

6.8 POWER AMPLIFIER (PA) SECTION.

6.8.1 PA SECTION AND OUTPUT NETWORK TEST PROCEDURE.

a. Remove top and bottom covers from PA section. Inspect PA Section components for evidence of overheating. Check alignment of switch contacts with MHz frequency dial set 2.5 MHz position. All contacts of the rear deck sections A and B should be engaged with S in this position.

b. Using CW receive mode, tune receive 2.555 MHz. Approach this frequency from end of 2 MHz Band when tuning PRESELECT control, and tune it for maximum noise in speaker.

c. Set PA TUNE control to 2.5 MHz position. Set TRANSMIT AUDIO control fully CCW. Connect dummy load (52 ohm, 200 watt) to TENNA connector J4 on rear of transceiver.

d. Using data given in Table 6.1 (para. 6.1) check DC voltages of V1, V2, and V3. Repair defective circuitry before proceeding to next:

e. Key transmitter in USB or LSB mode and PA BIAS ADJUST switch, S7 (left, rear corner bottom of transceiver) depressed, adjust MIN CURRENT potentiometer R4 (right, center bottom of transceiver) for S9 indication on panel S-meter.

f. Switch to CW, key transmitter and with BIAS ADJUST switch, S7 depressed, adjust TRANSMIT AUDIO control CW to obtain indication +60 on S meter. If this indication cannot be achieved, check RF Amplifier input to filter at terminal E69.

g. Obtain +60 indication on S meter as in step above, and adjust PA TUNE control for null indication on S meter. If null occurs at proper (2.5 MHz) point on PA TUNE dial, the PA is loading properly and the defect is probably in the output detuning circuit (Q3, etc.). If the null occurs about 3 MHz instead of 2.5 MHz position, look for shorted components in output network on I switch S6 section B, or in RF lines to antenna. If no null occurs, and the RF plate voltage of V2, and V3 is less than 70 volts, look for an



circuit in L6, or a short in C20 or bandswitch S6 section A components.

6.8.2 PA SECTION VOLTAGE MEASUREMENTS.

DC voltages readings for the stages in the PA Section are given in Table 6.1.

Table 6.1 — Main Frame Voltage Chart

PIN	V1,V2,V3	Q3	NOTES
DC VOLTAGES (a)			
1/E	2.2V	0.54V	AC Heater
2/B	6.3 VAC	1.1 V	
3/C	195V	11.8V	
4	2.2V		
5	-55 V		
6	2.2V		
7	0 V		
8	0 V		
CAP	780 V		

(a) All voltage readings taken in AM transmit mode with TRANSMIT AUDIO control fully ccw.

6.9 RF AMPLIFIER.

6.9.1 RF AMPLIFIER TEST PROCEDURE.

The RF Amplifier's relatively complex removal procedure, plus the difficulty of testing it outside the transceiver make it highly desirable to isolate a problem within it to the stage level, and if possible, to the component level, before removing the assembly. It is assumed that tubes V1 and V2 have been checked and found good.

a. Set transceiver for operation in CW mode at 2.555 MHz with TRANSMIT AUDIO control fully CCW. Connect a dummy load (52 ohm, 200 watt) to antenna connector J4. Set PA TUNE control to 2.5 MHz position. Refer to Table 6.2 and check DC voltages at pins at V1 and V2. Use tube extenders for these measurements.

b. Connect a signal generator, set for 3 volt output at 2.555 MHz, to E159 on RF Amplifier board (162-0260) through a 0.01 uF capacitor and a 1000 ohm resistor in series. Connect RF VTVM to E159, and without transmitter keyed, adjust PRESELECTOR control for peak indication on VTVM. (If peak reading cannot be obtained, problem is in

L4/S1-D circuits.) If peak indication is about 2.0 volts, reduce signal generator output to zero. Disconnect test equipment from E159.

c. Connect signal generator through .01 uF capacitor and 100 ohm resistor to E158 on RF Amplifier board (162-0260). Connect RF VTVM to E158. Reset generator for 2V output. Re-tune the PRESELECTOR for peak indication on VTVM. (If peak reading cannot be obtained, problem is in L3/S1-C circuits.) If peak indication is about 1.2 volts, check the front panel S meter for a reading of about +60. If no output is indicated, the trouble is in stage V2 circuits. If normal reading exists, set TRANSMIT AUDIO to CCW position and set signal generator to 6V output (which is an unloaded output indication of about 3V on front panel meter). Key transmitter. If 30 watts or more is indicated, the trouble is in stage VI input circuits L1/S1-A and L2/S1-B. Proceed to step d to check the input circuits.

d. Remove V1. Set signal generator for 6V rms (as read by rf vtvm) output at 2.555 MHz and connect through a .01 uF capacitor and 1000 ohm resistor to indicated check point in steps (1) through (4) in succession. Connect RF VTVM to same checkpoints. Tune PRESELECTOR control for peak VTVM indication in each step. The VTVM peak voltage should be near the value shown. If it is not, the indicated circuits are probably defective.

- (1) Pin 11 relay K1 (L1/S1-A circuits), 3.1 volts.
- (2) Terminal E156 (L2 and S1-B circuits), 3.9 volts
- (3) Terminal E158 (L3 and S1-C circuits), 4.3 volts.
- (4) Terminal E159 (L4 and S1-D circuits), 4.2 volts. Replace V1.

NOTE

If the signal traces through the RF Amplifier assembly correctly on transmit, but the RF Amplifier does not amplify the signal properly on receive, the problem may be transfer relay K1 or AGC Stage Q1. Test the Q1 AGC amplifier output in the following step. If the problem occurs on only certain frequencies, repeat the tests using one of the inoperative frequencies.



c. Connect DC VTVM to the junction of R8 and the collector of Q1. If the S-meter has a reading above zero, there should be a negative voltage at the test point. If the S-meter reads 0, the measurement at the test point should read +0.200.

If the receiver overloads on strong signals, and there is no S-meter reading, the problem probably lies in the AGC section of the IF Amplifier assembly and not in the AGC amplifier Q1. Refer to the IF Amplifier Test Procedure.

6.9.2 RF AMPLIFIER VOLTAGE AND RESISTANCE MEASUREMENTS.

DC and AC Voltage readings for the RF Amplifier tube and transistor stages, and resistance readings for the tube stages are given in Table 6.2.

6.9.3 RF AMPLIFIER ALIGNMENT PROCEDURES.

There are three procedures involved in RF Amplifier alignment: tracking tuned circuits, setting amplifier bias, and adjusting the feedback circuit. Tracking is critical and should be done only when absolutely necessary. Bias and feedback circuit adjustments should be made any time tubes are changed. If tracking is to be done, set bias and feedback before tracking.

6.9.3.1 Bias Adjustment.

- Set transceiver to receive with a zero S-meter reading.
- Connect DC VTVM to the collector of Q1.
- Set R31 for +0.200 volts on VTVM with zero S-meter reading.

6.9.3.2 Feedback Circuit Adjustment.

- Place the FUNCTION switch on STANDBY. Set the frequency dials for 8 MHz.
- Connect feedback detector test circuit to terminals E157 and E158. See figure 6.5.

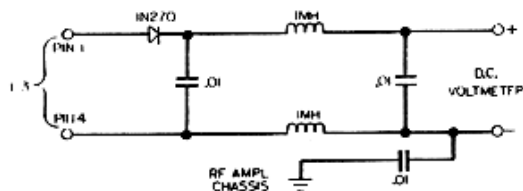

Figure 6.5 — Feedback Detector Test Circuit

Table 6.2 — RF Amplifier Voltage and Resistance Chart
CW receive mode except as indicated
TRANSMIT AUDIO fully CW throughout (not in tune position)

PIN	V1	V2	Q1	NOTE
DC VOLTAGES				
1/E	+0.200 V	2.7 V	1.7 V	
2/B	1.4V	+0.150 V	1.1 V	
3/C	0 V	0 V	+0.200 V	
4	0 V	0 V		
5	131V	0 V		
6	113V	0 V		
7	1.4V	180 V		
8		180 V		
9		0V		
AC VOLTAGES				
1/E	.29V	5.8 V	X	V1,V2 - Transmit mode
2/E			X	
3/C	0 V		X	
4	6.3 V	0 V		V1 - 60 CPS
5	8.1V	0 V		V1 - Transmit mode
6		6.3 V		V2 - 60 CPS
7		42 V		V2 - Transmit mode
9				
RESISTANCES				
1	230 K	68		All resistance measurements taken with negative ohmmeter lead connected to ground, with transceiver power OFF.
2	82	130K		
3	0	0		
4	0	0		
5	26 K	0		
6	17 K	0		
7	82	22 K		
8		22 K		
9		0		

c. Unplug P30 on front wall of PA high voltage section and connect signal generator to it through a .01 uF capacitor. Set generator for 1 volt output at 8 MHz.

d. Connect a DC voltmeter to the detector circuit as shown in figure 6.5.

e. Tune PRESELECTOR for maximum reading on voltmeter. Voltmeter should be on lowest range.

f. Adjust C51 to null this voltmeter indication.

g. Remove test setup, and reconnect P30.

6.9.3.3 Tracking.

a. Remove top and bottom covers, and stand transceiver up on left hand side.

b. Connect a dummy load and RF VTVM probe to transceiver antenna connector J4.

c. Provide temporary fan for cooling PA compartment. Fan should be placed near under side of chassis and provide steady stream of air.

d. Disconnect P46 located on bulkhead between 11 MHz Error Mixer and Divider/Spectrum generator assembly. Connect RF signal generator output through a 4.7K resistor to terminal 9 of K1, the transmit RF Amplifier input.

e. Unplug P30, and short the center pin of J30 directly to ground. Be careful not to damage the connector.

f. Preset all RF Amplifier variable tuning capacitors to their mid-range settings according to the diagram in figure 6.6.

g. Set signal generator for approximately 50 MV CW output at 2.000 MHz.

h. Set transceiver FREQUENCY controls for 2.000 MHz. Turn function switch to USB position.

NOTE

It will be necessary several times during the next steps to obtain a signal output from the PA stage to use as a tuning indication. Each time, key the transceiver and tune both the PRESELECTOR and the PA TUNE controls for maximum output as read on the VTVM. It will be necessary to adjust the output level of the signal generator to maintain a maximum of 50 volts RF output from the PA stage to use as an indicator of tuning. Do not exceed this level, as it may cause needless heating of the PA tubes. At first, very little output may be evident. As tuning progresses it will take less generator output (about 100 MV) to drive the amplifiers to the desired output level. Key transmitter for short periods when making adjustments.

i. Set the PRESELECTOR dial to the counter-clockwise stop, and then turn knob 1/4 turn clockwise.



Figure 6.6 – Variable Capacitors Shown at Midrange Capacitance Settings

j. Key transceiver, tune PA TUNE control for maximum output, and adjust L1 through L4 for maximum output. The positions of the slugs should be fairly even from coil to coil. Make sure tuning capacitors are all at half capacitance. Refer to figure 6.6.

k. Set FREQUENCY controls and signal generator to 5.500 MHz. Tune PRESELECTOR and PA TUNE controls for maximum output. Adjust coil slugs L1 through L4 for maximum transmitted response. Only a small tuning excursion should be necessary to make the four coils peak at one setting of the PRESELECTOR control.

l. Set Frequency controls and signal generator for 8.200 MHz. Peak PRESELECTOR and PA TUNE controls. Adjust C1, C13, C20, and C28 for maximum transmitted response.

m. Adjustments in steps k and l interact with each other. These steps should be repeated until no further retuning is necessary.

CAUTION

In the following steps, be careful not to disturb the settings of the coils and capacitors previously tuned.

n. Set signal generator and FREQUENCY controls to 2.200 MHz. Peak PRESELECTOR and PA TUNE controls. Adjust C36, C37, C38, and C40 for maximum output.

o. Set signal generator and FREQUENCY controls to 4.500 MHz. Peak PRESELECTOR and PA TUNE controls for maximum output. Adjust C4, C16, C23, and C31 for maximum output.

p. Set signal generator and FREQUENCY controls to 15 MHz (14.999). Peak PRESELECTOR



and PA TUNE controls for maximum output. Adjust C6, C18, C25, and C33 for maximum output.

q. The PRESELECTOR knob setscrews can be loosened, and the knob can be set to make the scale read accurately at any desired frequency. The frequency scale for the PRESELECTOR is intended to be approximate. A little experimenting may be necessary if it is desired to make the dial as accurate as possible over the entire frequency range of the transceiver.

6.9.4 RF AMPLIFIER ASSEMBLY REMOVAL AND INSTALLATION PROCEDURES.

The majority of repairs to the RF Amplifier assembly will probably be required to the band switch and main amplifier PC boards. The former cannot be removed without removing the entire RF Amplifier assembly; however, the main amplifier PC board can be removed separately, and instructions for its removal and installation precede those for the entire RF Amplifier assembly. The entire assembly should be removed for repair only when tests have definitely isolated defects requiring repair to the band switch or coil board sub-assemblies. Replacement of the coil tuning slugs can be made without removal of the entire amplifier assembly, and these procedures also precede those for the entire amplifier assembly.

6.9.4.1 Removal of RF Amplifier PC Board.

a. Removal of Compartment Covers.

1.) Remove six screws securing cover of bottom PA tube section and remove cover.

2.) Remove six screws securing cover of bottom of RF Amplifier assembly and remove cover.

3.) Remove two screws securing cover of bottom of MHz Oscillator assembly and remove cover, bending ground lug outward to clear cover.

b. Removal of PA TUNE Extension Shaft.

1.) Rotate PA TUNE control fully CCW.

2.) Rotate PA TUNE control as necessary to loosen both Allen screws in nylon couplers on front and rear of extension shaft.

3.) Work extension shaft forward into front coupler, and work rear coupler forward onto ex-

ension shaft to clear end of tuning shaft projecting from PA HIGH VOLTAGE section.

4.) Swing rear of extension shaft upward, and work front coupler free of PA TUNE control drive shaft and remove extension shaft.

c. Removal of PC Board.

1.) Unsolder three coaxial leads from PC board terminals E155-E156, E157-E158, and E159-E160.

2.) Unsolder black ground lead from metal tube shield base at socket of V1.

3.) Remove screw at each corner of PC board and in its center.

4.) Feed three coaxial cables disconnected in (1) above back through their respective holes in PC board, and remove PC board.

6.9.4.2 Replacement of RF Amplifier PC Board.

a. Replacement of PC Board.

1.) Insert end of coaxial cable from L2 on coil board into hole in upper corner of PC board near socket of V1, and solder center conductor to E156 and shield lead to E155.

2.) Insert coaxial cable from L3 on coil board into hole in upper center of PC board near socket of V1, and solder center to E158 and shield lead to E157.

3.) Insert coaxial cable from L4 on coil board into hole in upper corner of PC board near socket of V2, and solder center conductor to E159 and shield lead to E160.

4.) Solder black ground lead to metal tube shield base at the socket of V1.

5.) Install screw in each corner and center of PC board.

b. Replacement of PA TUNE Extension Shaft.

1.) Rotate end of tuning shaft projecting from PA HIGH VOLTAGE section fully CCW, then slightly CW to position flat spot on end upward.

2.) Install nylon coupling on one end of PA TUNE extension shaft on PA TUNE control shaft. Press nylon coupling onto rear of extension shaft far enough to permit installing this coupling on L6 tuning shaft projecting from PA HIGH VOLTAGE section.

3.) Press nylon couplings on both ends of extension shaft outward until shaft turns freely.

4.) Rotate extension shaft CCW to position one of Allen screws in nylon coupling over flat spot in PA section shaft, and tighten both Allen screws in both nylon couplings.

5.) Rotate PA TUNE control fully CCW and loosen set screw in indication ring under control knob. Rotate ring to position pointer to reference mark on front panel (slightly CCW from 2 MHz position), and tighten set screw.

c. Replacement of Compartment Covers.

1.) Position cover on bottom of PA tube section, and install six screws securing it in place.

2.) Position cover on bottom of RF Amplifier assembly, and install six screws securing it in place.

3.) Position cover on bottom of MHz Oscillator assembly, and install two screws securing it in place.

6.9.4.3 Removal of RF Amplifier Assembly.

a. Decoupling of Band Switch Shafts in PA and MHz Oscillator Assemblies.

1.) Remove covers as described in paragraph 6.9.4.1 (a).

2.) Rotate MHz Oscillator control as necessary to permit loosening of two set screws in shaft collar in front of phenolic board separating PA switch, S6, sections A and B.

3.) Set MHz Oscillator control to 2 MHz position; slide PA switch S6 shaft backward, using care not to damage wiring to relay K4; and remove nylon coupling between PA and RF amplifier switch shafts.

4.) Press on nylon shaft coupling between the RF amplifier and MHz oscillator switch shafts to

slide former rearward until coupling is flush with front edge of RF amplifier chassis.

b. Decoupling PA TUNE and PRESELECTOR Shafts in RF Amplifier and PA Section.

1.) Remove PA TUNE Extension shaft as described in paragraph 6.9.4.1 (b).

2.) Rotate PRESELECTOR control fully CCW and then slightly CW to position coupler bar on front panel control shaft vertically.

c. Disconnection of Wiring in Lower Sections of RF Amplifier and PA.

1.) Unsolder white/yellow PA grid lead from green standoff, E69, in front of ACC board. Pull this lead through large rubber grommet down into RF amplifier coil board section.

2.) Unsolder ground wire from ground lug located at lower center of rear of RF amplifier section.

3.) Unsolder white/black wire from feed-thru post E70, located next to ground lug in step 2 above.

d. Disconnection of Wiring to Upper Section of RF Amplifier.

1.) Disconnect coaxial cable connector, P30, from front wall of PA HIGH VOLTAGE section.

2.) Disconnect coaxial cable connector, P50, on front wall of RF amplifier chassis.

3.) Disconnect five pin plug, P31, by pulling it upward from RF amplifier PC board (162-0260).

4.) Unsolder following leads from transfer relay, K1, and vicinity (See figure 6.4 for K1 pin number).

a.) Unsolder coaxial cable/shield lead from ground lug under screw mounting relay, K1, to front wall of RF amplifier assembly.

b.) Unsolder orange wire from E102 on the receiver protector from pin 8 of K1.



c.) Unsolder yellow wire from pin 14 of K1.

d.) Unsolder blue wire from standoff next to K1.

e.) Physical Removal of RF Amplifier Assembly.

1.) Remove six Allen screws securing RF amplifier assembly to chassis.

2.) Check that nylon coupler on front end of band switch shaft does not extend beyond wall of RF amplifier assembly, and that coupler bar on rear of PRESELECTOR control shaft is positioned vertically.

3.) Remove RF amplifier assembly by lifting it upward while guiding P31 cable assembly into notch in edge of mounting flange on side of RF amplifier assembly and working cable against chassis.

6.9.4.4 Disassembly of RF Amplifier.

a. Removal of Bandswitch PC Board Assemblies.

1.) Remove coupler on rear of bandswitch shaft and remove shaft through front (A section end) of assembly.

2.) Remove three screws securing ends of chassis-shields between switch sections to outside shield, remove six screws securing outside shield to assembly chassis, and remove outside shield.

3.) Remove ground lugs of chassis-shields between switch sections A and B, between B and C.

4.) Unsolder leads from four terminals L1 and L2 sections of coil board.

5.) Remove 2 screws securing chassis-shield between sections A and B to RF Amplifier chassis. Pull PC board assembly back slightly, and unsolder coaxial cable from section B PC board. Remove bandswitch PC board assembly.

6.) To separate the A and B section PC boards for slight repairs, unsolder C9, C10, C11, & C12 from their connections on section B PC board.

7.) Remove the retaining screws, nuts, lock washers, and spacers at each corner of the boards.

8.) Remove ground lug on the chassis shield between sections C and D, and follow the procedure in steps (4) and (5) above applying them to section C and D instead of A and B.

9.) Remove bandswitch PC board assembly

10.) To separate the C and D section PC boards slightly for repairs, remove the retaining screws, nuts, lock washers, and spacers at each corner of the board.

b. Removal of RF Coil Board Assembly is required only to replace one of the coils. Other components, including ferrite tuning slugs, can be replaced without removal of the coil board.

1.) Remove bandswitch PC board assemblies as above.

2.) Remove two screws fastening center shield to assembly base, and remove shield.

3.) Remove four screws at corners of coil board, and using caution to avoid breaking tuning slugs, remove coil board. Removal of three coaxial cables still attached to board is not required for repair.

6.9.4.5 Reassembly of RF Amplifier Assembly.

a. Installation of RF Coil Board

1.) Position coil board over slugs with trimmer capacitors toward side of the amplifier assembly and beginning with one of end slugs and proceeding in sequence, insert four tuning slugs in sleeves in coil forms, and then lower coil assembly onto amplifier chassis.

2.) Install four screws fastening corners of coil board to four spacers.

3.) Solder three coax cables to coil board as follows (see figure 8.1).

a.) Connect coaxial cable no. 1 center conductor to pin 3 and shield lead to pin 2 on L1.

b.) Connect coaxial cable no. 2 center conductor to E171 and shield lead to E134.

c.) Insert coaxial cable no. 3 through outside hole in C40 and solder an insulated ground lead from its shield to pin 2 of L4. Solder the center conductor to E127.

4.) Check operation of tuning slug rack mechanism.

5.) Position shield between sections B and C, and install 3 screws securing same.

6.) Install bandswitch sections A and B, and C and D assemblies as per instructions in paragraph 6.9.4.5 (b).

b. Installation of Bandswitch PC Assemblies.

1.) Set switch wiper arms of both sections to 2 MHz position as shown on bandswitch section D in figure 8.1.

2.) Using the sections A and B assembly as a guide for assembling sections C and D, or vice versa, mount section A or C board on side of chassis-shield away from flanges, using 9/16" spacers, and mount section B on D board on opposite side using 1/4 inch spacers.

3.) For sections A and B, insert leads from C9, C10, C11, and C12 through the proper holes in section B PC board; and solder C9 lead to E103, C10 lead to E105, C11 lead to C107, and C12 lead to E109.

4.) Insert PC board assembly into place on RF Amplifier chassis leaving PC board assembly back from coil board sufficiently to solder coaxial cables to the PC boards as follows:

a.) Connect center conductor of coaxial cable adjacent to section A to E171 and shield lead to E172 on coil board.

b.) Connect center conductor of coaxial cable adjacent to section B to E114, and shield to E115 to section B board.

c.) Connect center conductor of coaxial cable adjacent to section C to E121 and shield lead to E122 of section C board.

d.) Connect center conductor of coaxial cable adjacent to section D to E128 and shield lead to E129 on section D board.

5.) Push assembly into position against coil board and insert two retaining screws through holes in RF Amplifier PC board.

6.) Connect white, bare, yellow, and green wires from PC boards A through D respectively to listed terminals on coil board (162-0250) in sequence given:

a.) White to E134, E138, E142, and E146.

b.) Bare to E172, E175, E178, and E181.

c.) Yellow to E171, E174, E177, and E180.

d.) Green to E170, E173, E176, and E179.

7.) Install ground lugs on three shields between sections A-B, B-C, and C-D.

8.) Position outside shield on RF Amplifier chassis, and install 6 retaining screws.

9.) Insert switch shaft from outside shield end of switch assembly; and install coupler bar, tightening one set screw on flat area of shaft.

6.9.4.7 Installation of RF Amplifier Assembly.

a. Preliminary Mechanical Alignment.

1.) Set MHz Oscillator control knob to 2 MHz.

2.) Position wiper of bandswitch section D to 2 MHz position as indicated on figure 8.1.

3.) Install nylon coupler on section A end of switch shaft and position it flush with front of RF amplifier assembly.

4.) Install nylon coupler on same end of RF coil (slug) tuning rack control shaft; and rotate it fully CCW, and then CW to position slot in nylon coupler vertically.

5.) Ascertain that shaft in PA MHz selector switch is inserted rearward far enough to engage both sections A and B, and then rotate switch shaft to engage all 6 contacts, (including common) on rear of both sections A and B with their respective wiper arms.

6.) Set PRESELECTOR control knob on front panel to lower end of 2 MHz band, then rotate CW to position coupler engaging bar (on end of shaft)



vertically to match position of nylon coupler in step (4) above.

7.) Set PA TUNE control knob on front panel to reference line just CCW from lower end of 2 MHz band position (above the "A" in "PA TUNE").

8.) Rotate tuning shaft in PA coil L6 fully CCW, then rotate CW to position flat spot up.

b. Mechanical Installation of RF Amplifier Assembly and Upper Section Tuning Components.

1.) Lower RF Amplifier assembly through hole in PA section of transceiver, while insuring that:

a.) The cable, which plug P31, is part of, is guided into notch in transceiver chassis on outside edge of amplifier hole and into notch on outside edge of RF Amplifier chassis.

b.) Clearance is adequate for couplers on both ends of bandswitch shaft.

2.) Mate nylon coupler of RF coil (slug) tuning rack control shaft with coupler bar on end of PRESELECTOR control shaft.

3.) With amplifier properly seated, check clearance of cable 46, that of plug P31, and leads from relay K1.

4.) Using paraffin or beeswax on end of screwdriver to hold screw, install six screws securing RF Amplifier assembly to transceiver chassis.

5.) Rotate PRESELECTOR control fully CCW, and set pointer on indicator ring precisely to low end of 2 MHz band.

6.) Install nylon coupling on one end of PA TUNE extension shaft of PA TUNE control shaft as far as it will go easily. Press nylon coupling onto rear of extension shaft far enough to permit installing this coupling on L6 tuning shaft projecting from PA HIGH VOLTAGE section. Tighten one set screw on flat spot of L6's tuning shaft.

7.) Push nylon couplers on both ends of PA TUNE extension shaft outward until shaft turns freely, and tighten remaining Allen set screws in both nylon couplers.

8.) Rotate PA TUNE control fully CCW. Loosen both set screws in indicating ring under control knob. Position pointer to reference mark on front panel (slightly CCW from 2 MHz position) and tighten set screws.

c. Installation of Lower Section Tuning Components.

1.) Place transceiver on right side and push bandswitch shaft toward front, seating slot in nylon coupler on bar on coupler on MHz Oscillator shaft.

2.) Insert nylon coupler on bar on rear of RF Amplifier bandswitch shaft.

3.) Press shaft in PA bandswitch S6 in PA lower section toward front, mating bar on end of shaft in slot in nylon coupler installed in (2) above.

4.) Rotate MHz Oscillator control to position flat side of PA bandswitch S6 shaft downward.

5.) Pressing S6 shaft forward to firmly seat coupler as in 1 and 3 above, press shaft collar in front section of S6 rearward against phenolic board at rear of front section and tighten set screws, insuring one set screw is on flat side of shaft.

6.) Set MHz Oscillator control to 2 MHz position and check wiper arm positions of PA bandswitch to insure they are covering all six contacts on rear side of both sections. Check wiper arm positions in bandswitch assembly in RF Amplifier to insure they are 2 MHz position shown in figure 8.1. If misalignment of either switch assembly has occurred, correct by loosening set screws in bar couplers ahead of switch, realigning as necessary, and tightening set screws again. Realignment of RF Amplifier bandswitch assembly will require realignment of PA bandswitch S6.

d. Electrical Connections to Bottom of Chassis.

1.) Solder black/white wire from E148 on coil board to feed through connector E70, on front wall of PA switch S6 compartment (connected to C21 on S6).

2.) Feed yellow/white wire from E147 on coil board through large rubber grommet into lower compartment of PA tube section, and solder to standoff E69 next to front tube socket. Dress this wire near chassis.

3.) Solder bare ground wire from E124 on coil board to ground lug next to E70 (See step (1) above).

e. Electrical Connections to Top of Chassis.

1.) Insert plug, P31, into connector on RF Amplifier PC board (162-0260).

2.) Plug coaxial cable no.46 into coaxial connector on front of RF Amplifier assembly.

3.) Plug in coaxial cable from center of PC board 162-0260 into connector in front of PA high voltage section running coaxial cable beneath PA TUNE extension shaft.

4.) Referring to figure 6.4 for relay terminal numbers, solder center conductor of coaxial cable in cable feeding plug, P31, to pin 8 of relay K1; and solder shield lead to ground lug secured by screw mounting K1.

5.) Solder white/black/yellow wire to pin 14 of K1, and solder blue wire to standoff next to K1.

6.) Fasten MHz Oscillator cover with two screws and ground lug; RF Amplifier bottom cover with 6 screws; and PA tuning switch, S6, cover with 6 screws.

6.10 DIVIDER/SPECTRUM GENERATOR.

Refer to figure 8.3 and 8.4 for parts location and schematic diagrams.

6.10.1 DIVIDER/SPECTRUM GENERATOR TEST PROCEDURE.

It is necessary first to determine which areas of the Divider/Spectrum Generator circuitry are faulty. Using the Heterodyne Voltmeter, check each spectrum according to table 6.3-A. Connect to test points indicated. The transceiver should be set for AM reception.

Knowing which spectrums are faulty, it should be determined which circuitry may be faulty by checking the block diagram in figure 4.6. The sections responsible for proper operation of the spectrum generators are dependent on other sections, and understanding how these sections are related will provide a logical method of isolating the trouble to one section.

For example, if the 10 KHz spectrum is not as it should be according to table 6.3-A, but the 1 kHz spectrum is unaffected, it is correct reasoning to conclude that the trouble must be in the 10 kHz spectrum generator stage, since the 1 kHz spectrum generator and frequency divider, which are unaffected, also depend on proper operation of the 10 kHz frequency divider. Thus, the trouble is occurring between the 10 kHz frequency divider and the 10 kHz spectrum output. The only stage between the two points is the 10 kHz spectrum generator. Similar reasoning will locate other faults.

The operation of the 1 MHz amplifier/clipper and pulse forming stages, the 1 MHz, 100 kHz, and 10 kHz 2:1 and 5:1 frequency divider (multivibrator) stages, and the 100 kHz, 10 kHz, and 1 kHz keyed oscillator (spectrum generator) stages can be checked with an oscilloscope as described below.

NOTE

References to top, left, etc, are with respect to the top of the component side of the assembly with the transceiver upright.

Table 6.3A – Spectrum Generator Tests

Test Point - Output Terminal	Spectrum	Frequencies to Check	Level
E84	MHz	11.0 to 12.0 at 1 MHz intervals.	8 MV +10-2MV
E87	100 kHz	28.1 to 29.0 MHz at 100 kHz intervals	5 MV ±2 MV
E89	10 kHz	1.11 to 1.20 MHz at 10 kHz intervals	6 MV ±3 MV
E91	1 kHz	1.8 MHz	4.5 MV ±2. MV

a. Connect oscilloscope to center conductor of P43 (on Divider/Spectrum generator assembly) from Frequency Standard. The observed 1 MHz waveform should resemble the one shown in figure 6.7.

b. Reconnect oscilloscope to base of Q1 (left end of R72) the 1 MHz waveform should resemble the one shown in figure 6.8A. Reconnect oscillo-



scope to collector of Q1 (or bottom of R2). The observed waveform should resemble the one shown in figure 6.8B.

c. Reconnect oscilloscope to collector of pulse shaper stage Q14 (or left end of R47). The observed 1 MHz waveform should resemble the one shown in figure 6.9.

d. Reconnect oscilloscope to terminal E84. The observed 1 MHz spectrum waveform should resemble the one shown in figure 6.10.



Figure 6.7 – Frequency Standard, Output at P43, Waveform

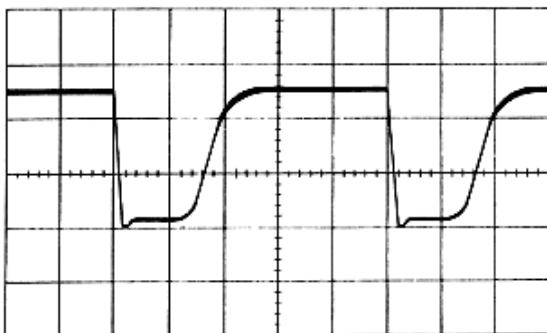

Figure 6.8A – Q1, Base Waveform

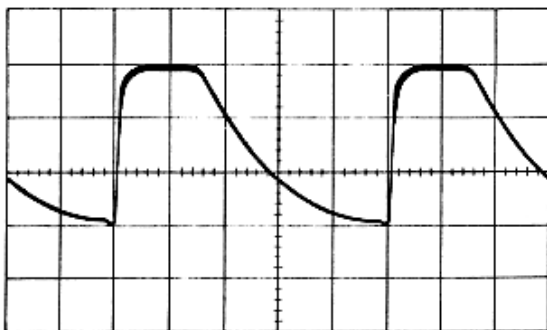

Figure 6.8B – Q1, Collector Waveform

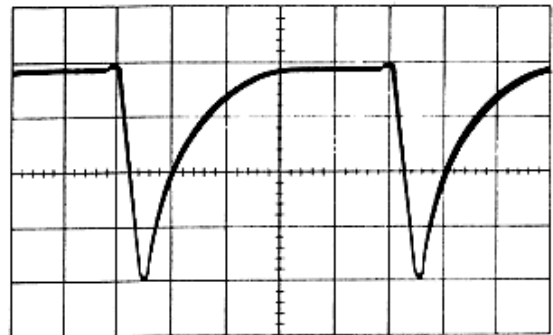

Figure 6.9 – Q14, Collector Waveform

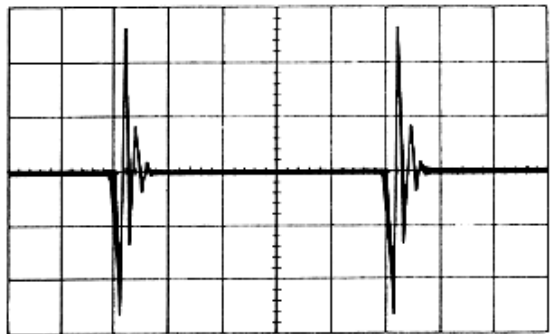

Figure 6.10 – Terminal E84 Waveform

e. Reconnect oscilloscope to collector of 500 kHz multivibrator stage Q3 (or top of R7). The observed waveform should resemble that shown in figure 6.11.

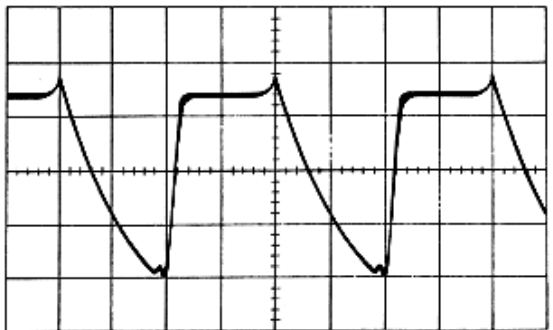

Figure 6.11 – Q3, Collector Waveform

f. Reconnect oscilloscope to base of 100 kHz buffer amplifier Q16 (or top of R14). The observed waveform should resemble the one shown in figure 6.12.

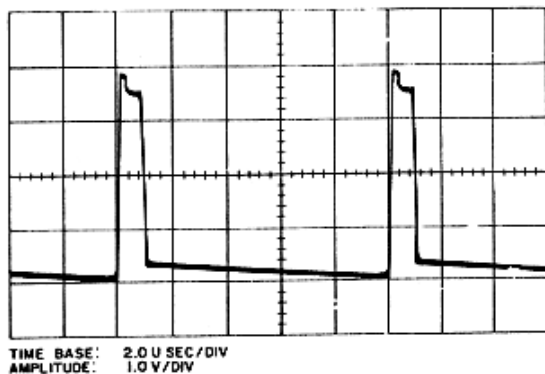

Figure 6.12 – Q16, Base Waveform

g. Reconnect oscilloscope to emitter of keyed oscillator Q17 (or left end of R51). The observed 100 kHz waveform should resemble the one shown in figure 6.13.

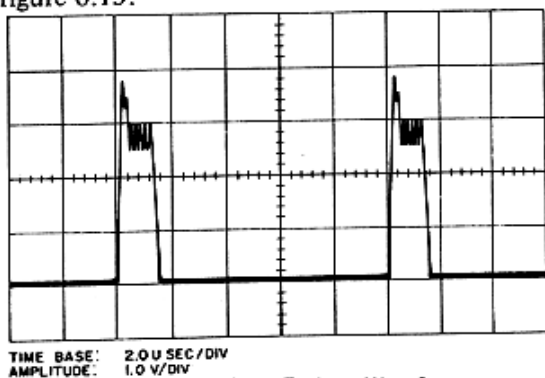

Figure 6.13 – Q17, Emitter Waveform

h. Reconnect oscilloscope to terminal E87. The observed 100 kHz spectrum waveform should resemble the one shown in figure 6.14.

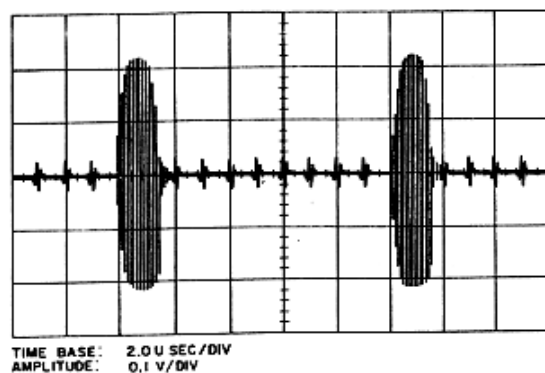

Figure 6.14 – Terminal E87 Waveform

i. Reconnect oscilloscope to collector of 50 kHz multivibrator stage Q7 (or top of R21). The observed waveform should resemble the one shown in figure 6.15.

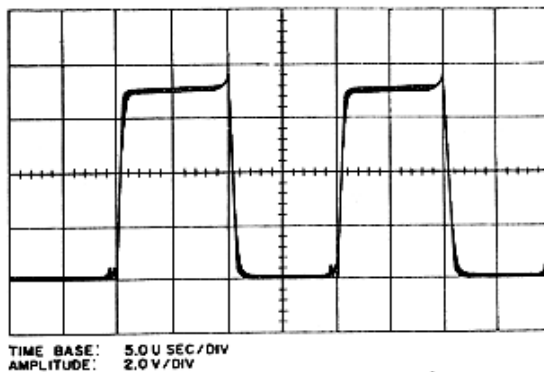

Figure 6.15 – Q7, Collector Waveform

j. Reconnect oscilloscope to collector of 10 kHz multivibrator stage Q9 (top of R28). The observed waveform should resemble the one shown in figure 6.16.

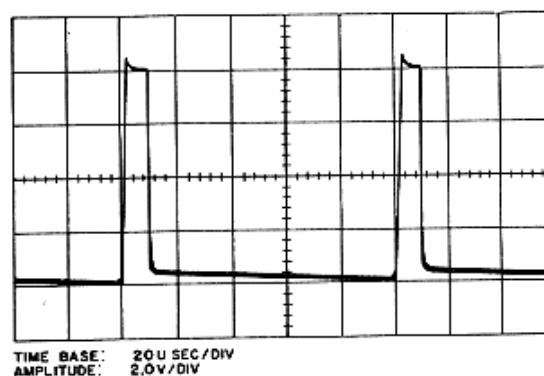

Figure 6.16 – Q9, Collector Waveform

k. Reconnect oscilloscope to emitter of keyed oscillator Q18 (or bottom of R54). The observed 10 kHz waveform should resemble the one shown in figure 6.17.

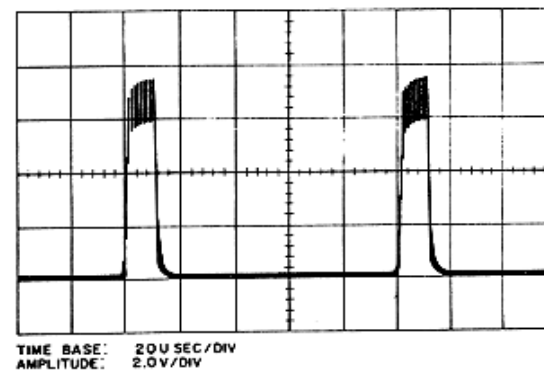

Figure 6.17 – Q18, Emitter Waveform

l. Reconnect oscilloscope to terminal E89. The observed 10 kHz spectrum waveform should resemble the one shown in figure 6.18.

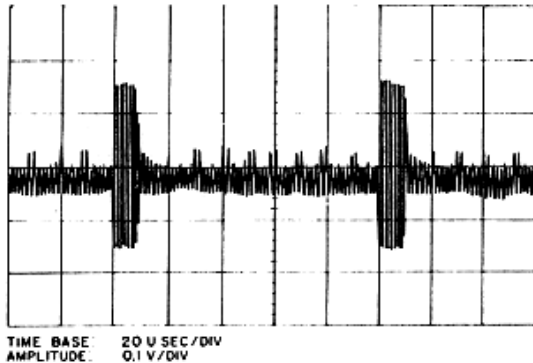

Figure 6.18 – Terminal E89 Waveform

m. Reconnect oscilloscope to collector of 5 kHz multivibrator stage Q11 (or top of R32). The observed waveform should resemble the one shown in figure 6.19.

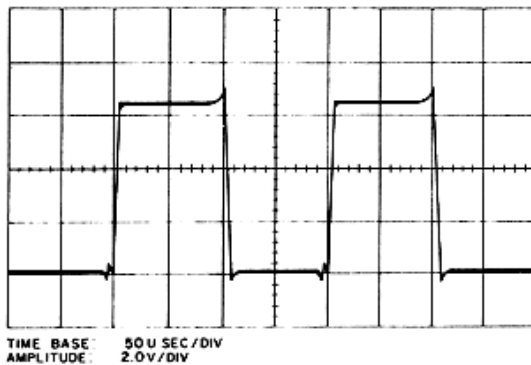

Figure 6.19 – Q11, Collector Waveform

n. Switch to CW mode and reconnect oscilloscope to collector of 1 kHz multivibrator stage Q13 (or bottom of R43). The observed waveform should resemble the one shown in figure 6.20.

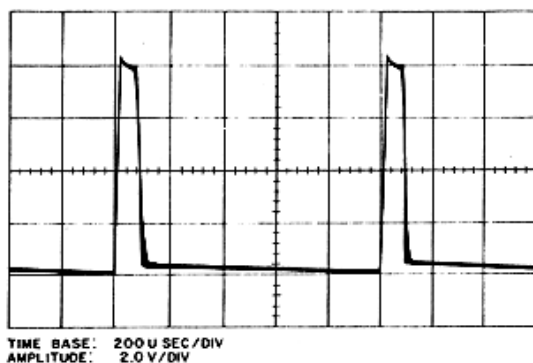

Figure 6.20 – Q13, Collector Waveform

o. Remain in CW mode and reconnect oscilloscope to emitter of keyed oscillator Q19 (or left end of R57). The observed 1 kHz waveform should resemble the one shown in figure 6.21.

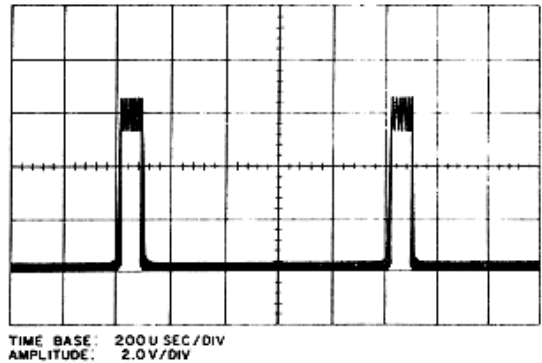

Figure 6.21 – Q19, Emitter Waveform

p. Reconnect oscilloscope to the junction of R61 and T4 pin 4 (or right side of R61). The observed 1 kHz spectrum waveform should resemble the one shown in figure 6.22.

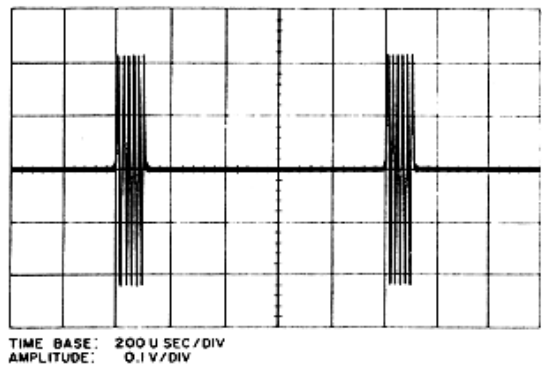

Figure 6.22 – Right Side of R61 Waveform

6.10.2 DIVIDER/SPECTRUM GENERATOR VOLTAGE MEASUREMENTS.

DC and certain AC voltage measurements for the Divider/Spectrum Generator stages are given in table 6.3-B. The waveforms shown in figures 6.8 through 6.22 present more detailed AC voltage information than VTVM readings, and with the exception of the RF output level of each of the spectrum generators, AC VTVM readings are not included in table 6.3-B. Those given in this table for the spectrum generators were taken with an RF VTVM, while those given in table 6.3-A were taken with the Heterodyne Voltmeter.



Table 6.3B – Divider/Spectrum Generator Voltage Chart

STAGE	EMITTER	BASE	COLLECTOR	NOTES
DC VOLTAGES				
Q1	9.2 V	9.2 V	6.1 V	
Q2	8 V	8.6 V	4.6 V	
Q3	8 V	8.6 V	4.6 V	
Q4	6.5 V	6.0 V	9 V	
Q5	8.8 V	9.0 V	1.2 V	
Q6	8.2 V	8.4 V	4.6 V	
Q7	8.2 V	8.4 V	4.6 V	
Q8	6.6 V	6 V	9 V	
Q9	9 V	9.1 V	1.4 V	
Q10	8.1 V	8.3 V	4.6 V	
Q11	8.2 V	8.3 V	4.6 V	
Q12	6.4 V	5.6 V	9 V	
Q13	9.2 V	9.1 V	.94V	
Q14	.6 V	-.7 V	7.9 V	
Q15	8.1 V	7.8 V	0 V	
Q16	1.1 V	.52V	0 V	
Q17	4.8 V	7.2 V	0 V	
Q18	1.25V	1.15V	0 V	
Q19	.86V	.76V	0 V	
Q20	4.1 V	4.3 V	7.9 V	
AC VOLTAGES (a)				
E84			700 MV	
E87			70 MV	
E88			3 MV	
E91			7 MV	

(a) Using Boonton 91CA

6.10.3 DIVIDER/SPECTRUM GENERATOR ALIGNMENT PROCEDURE.

a. Set up transceiver to receive on 2.444 MHz in any mode except AM.

b. Connect oscilloscope to the collector of Q1 (or the right side of R2), and adjust R66 for a pulse width of 0.25 usec at the flat top of the waveform. Waveform should resemble figure 6.8B.

c. Connect oscilloscope to the junction of R13 and R14. Set R11 to the center of the range which results in a waveform with time between pulses equal to and amplitude close to those shown in figure 6.12. For example, if the time between pulses is correct over a range of 3 1/2 turns of R11, set R11 exactly 1 3/4 turns from the setting at which the time between pulses jumps to the next longer or next shorter value.

d. Connect oscilloscope to the junction of R26 and the collector of Q9. Set R24 to the center of the range which results in a waveform with time between pulses equal to and amplitude close to those shown in figure 6.16.

e. Connect oscilloscope to the junction of R42 and the collector of Q13. Set R38 to the center of the range which results in a waveform with time between pulses equal to and amplitude close to those shown in figure 6.20.

f. Connect Heterodyne Voltmeter, set for 21.9 MHz, to R34 at the output of FL4 on the 11.6 MHz Error Mixer assembly, and peak the Voltmeter on the signal.

g. Place the 100 kHz knob on the 4 position, and tune T2 on the Divider/Spectrum Generator assembly for the strongest peak on the Heterodyne Voltmeter. Rotate the 100 kHz knob from 0 to 9, and check meter for a change of less than 6 dB on any frequency from the reading on the 4 position. If the change is more than 6 dB, a very slight adjustment of T2 should decrease the amount of variation. The peak level should be about 5 MV when correctly tuned.

h. Connect Heterodyne Voltmeter, set for 646.5 kHz, to the junction of R5 and the base of Q2 on the 455 kHz Error Mixer assembly. Set the 10 kHz transceiver knob to the 4 position, and peak the Voltmeter on the signal.

i. Tune T3 on the Divider/Spectrum Generator assembly for the strongest peak on the Voltmeter. Rotate the 10 kHz knob from 0 to 9, and check level at each frequency. If the levels are not within 6 dB, a slight readjustment of T3 should decrease the amount of variation. The level, when correctly tuned, should be about 30 MV.

j. Connect the Heterodyne Voltmeter to the junction of R15 and the base of Q4 on the 455 kHz Error Mixer assembly, and with the 1 kHz knob on position 4, peak the Voltmeter on the 1.1015 MHz frequency.

k. Tune T4 on the Divider/Spectrum Generator assembly for the strongest peak on the Voltmeter. Rotate the 1 kHz knob from 0 to 9, and check level at each frequency. If the levels are not within 6 dB, a slight readjustment of T4 should decrease the amount of variation. When correctly tuned, the level should be about 3 MV.

The test procedure can also be performed using an RF VTVM; in place of the Heterodyne Voltmeter by substituting the following steps for their counterparts in the above procedure.



f. Connect RF VTVM to output FL4 (at bottom of R34) on 11.6 MHz Error Mixer Assembly. Disconnect P34 and P36.

h. Reconnect P34 and P36. Disconnect P12 and P15 at the 455 kHz Error Mixer Assembly and connect RF VTVM to the junction of R5 and the base of Q2.

j. Reconnect P12 and P15. Disconnect P13 and P14. Connect RF VTVM to the junction of R15 and the base of Q4 on 455 kHz Error Mixer.

l. Reconnect P13 and P14.

6.10.4 DIVIDER/SPECTRUM GENERATOR ASSEMBLY REMOVAL AND INSTALLATION PROCEDURES.

6.10.4.1 Removal From Transceiver.

a. Prepare Divider/Spectrum Generator assembly for removal by unplugging four coaxial cables from it to other assemblies at those assemblies, unplugging coaxial cable from J43, and unsoldering leads from terminals E81 and E83, and from ground lug near lower front corner of assembly.

b. Remove four screws, one in each corner, securing assembly to chassis, and remove assembly by sliding it up and out of chassis.

6.10.4.2 Installation In Transceiver.

a. Insert assembly into position on transceiver chassis, and install four retaining screws, one at each corner.

b. Solder yellow/brown wire to terminal E81 (See figure 8.3).

c. Solder white inner conductor of shielded cable 23 to terminal E83.

d. Solder black ground lead from terminal E85 to ground lug on partition near lower front corner.

e. Plug coaxial cable number 36 into J36 on 11.6 MHz Error Mixer board, and press rubber grommet (on cable) into notch in chassis.

f. Plug coaxial cable number 46 into jack in center of partition on front of Divider/Spectrum Generator board (mates with coaxial cable number 46 from 11.6 MHz Error Mixer board).

g. Plug coaxial cable numbers 14 and 15 into J14 and J15 respectively on 455 kHz Error Mixer board.

h. Plug coaxial cable number 43 (from Frequency Standard) into J43 on Divider/Spectrum Generator board.

6.11 11.6 MHz ERROR MIXER.

Refer to figures 8.5 and 8.6 for parts location and schematic diagrams.

6.11.1 11.6 MHz ERROR MIXER TEST PROCEDURE.

a. Set transceiver for 2.555 MHz, CW receive.

b. Q1, Q2, and Q3 operation – Connect RF VTVM to junction of CR1 and CR2. If more than 200 MV is present, Q1, Q2, and Q3 circuits are correct; proceed to step c. If a signal is not present at CR1-CR2, a Q1, Q2, or Q3 circuit is defective; proceed to step f.

c. Q6, Q7, and Q8 operation – Remove P35 and P42. Measure AC voltage at base of Q9 (accessible at bottom of R41). If 90 to 260 MV is present, Q6, Q7, and Q8 circuits are correct. Reinstall P35 and P42 and proceed to step d. If a signal is not present, the Q6, Q7, or Q8 circuit is defective. Reinstall P35 and P42 and proceed to step g.

d. Q4 operation – Remove P34 and ground collector of Q8 (short R40). Measure AC voltage at emitter of Q9 (accessible at left of R43). If 8 to 15 MV is present, Q4 circuit is correct; reinstall P34, remove ground from collector of Q8, and proceed to step e. If a signal is not present, Q4, FL-2 or a component of the Q4 circuit is defective.

e. Q9 and Q5 operation – Measure AC voltage at the base of Q5 (accessible at R39). If 30 to 90 MV is present, the fault is in the Q5 or T2 circuit. If a signal is not present, the fault is in the Q9 or Q5 circuits, or FL3.

f. Q1, Q2, or Q3 circuit failure – Compare Q1 voltages with those of table 6.4. If the collector of Q1 is less than 150 MV, AC, the fault is in the Q1 circuit. If the Q1 AC voltages are correct, the fault is in Q2 or Q3 circuits. In Q2 and Q3 circuits the DC voltage should be very close to these of table 6.4, and large deviations will indicate most of the possible component failures. If all



the DC voltages are correct but no signal is present at Q3, FL1 is defective.

g. Q6, Q7, or Q8 circuit failure – Perform same procedure as in step f except substituting Q6 for Q1, Q7 for Q2, and Q8 for Q3.

6.11.2 11.6 MHz ERROR MIXER VOLTAGE MEASUREMENTS.

DC and AC voltage measurements are given for the 11.6 MHz Error Mixer stages in table 6.4. Make measurements using any receiving mode.

6.11.3 11.6 MHz ERROR MIXER ALIGNMENT PROCEDURE.

The following procedure is used in tuning the RF transformer circuits in the 11.6 MHz Error Mixer assembly. Except as otherwise specified, the transceiver is operated in the receive mode at 2.555 MHz.

a. Connect RF VTVM to top of CR1; and tune C5, C8, and T1, respectively, for peak indication (about 300 MV).

b. Reconnect RF VTVM to junction of R12 and R13, and retune C5 and C8 for peak indication.

c. Reconnect RF VTVM to top of R36; and with P36 removed, tune C31 and C33 for peak indication. Replace P36.

d. Reconnect RF VTVM to right side of CR3; and tune C20, C22, and T2 for peak indication.

e. Reconnect RF VTVM to bottom of R39; and retune C20, C22, C34, C36, and C16 for peak indication.

f. Repeat step c.

6.11.4 11.6 MHz ERROR MIXER ASSEMBLY REMOVAL AND INSTALLATION PROCEDURES.

6.11.4.1 Removal From Transceiver.

a. Prepare 11.6 MHz Error Mixer assembly for removal by unplugging five coaxial cables to it from other assemblies, unplugging coaxial cable number 9 from it to translator at that assembly, removing retaining nut and coaxial connector (terminating coaxial cable number 46) from rear partition,

Table 6.4 – 11.6 MHz Error Mixer Voltage Chart

STAGE	EMITTER	BASE	COLLECTOR	NOTES
DC VOLTAGES				
Q1	7.4V	7.2V	0.5V	
Q2	10 V	9.8V	0 V	
Q3	10 V	9.9V	0 V	
Q4	9.8V	9.6V	0 V	
Q5	10 V	9.8V	0 V	
Q6	7.2V	7.0V	0.5V	
Q7	9.8V	9.6V	0 V	
Q8	10 V	9.9V	0 V	
Q9	11 V	10.5V	0 V	
AC VOLTAGES				
Q1	X	43 MV	380 MV	J36 disconnected
Q2	13 MV	73 MV	X	J36 disconnected
Q2	80 MV	80 MV	2.6 V	
Q3	3.5 MV	20 MV	750 MV	
Q4	50 MV	7.3 MV	230 MV	
Q4	60 MV	17 MV	X	J42 disconnected
Q4	5.4 MV	7.4 MV	X	J35 disconnected
Q5	2.5 MV	48 MV	930 MV	
Q6	6 MV	37 MV	320 MV	
Q7	15 MV	9 MV	X	P33 disconnected
Q7	38 MV	88 MV	1.3 V	
Q8	7.5 MV	19 MV	100 MV	P34 and P36 disconnected
Q8	110 MV	15 MV	590 MV	P33 disconnected
Q8	110 MV	20 MV	700 MV	
Q9	20 MV	140 MV	140 MV	
Q9	6.3 MV	3.3 MV	5.0 MV	P35 and P42 disconnected
Q9	18 MV	140 MV	320 MV	P34 disconnected. Collector of Q8 grounded.

unsoldering lead from terminal E55, and unsoldering black ground lead (one from each of terminals E182 and E184) from ground lugs on partition near upper front and lower rear corners of board.

b. Remove four screws, one at each corner of board. Remove screw fastening lower shield to bottom of chassis, and remove board by sliding up and out of chassis.

6.11.4.2 Installation In Transceiver.

a. Insert assembly into position on transceiver chassis; and install four retaining screws, one at each corner. Install screw (flat head) securing lower shield to bottom of chassis.

b. Solder yellow/Brown wire to terminal E55 (see figure 6.4).

c. Solder black ground leads from terminals E182 and E184 to ground lugs on partition near lower rear and upper front corners of board, respectively.

d. Plug coaxial cable number 9 into J9 on translator board.



c. Install coaxial cable jack J46 in center of rear partition, and plug into it coaxial cable number 46 from Divider/Spectrum Generator.

f. Plug coaxial cable numbers 33, 34, 35, 36 and 42 into J33, 34, 35, 36 and 42 respectively.

6.12 455 kHz ERROR MIXER.

Refer to figures 8.7 and 8.8 for parts location and schematic diagrams.

6.12.1 455 kHz ERROR MIXER TEST PROCEDURE.

a. Set transceiver for 2.555 MHz USB reception.

b. Connect RF VTVM to the base of mixer Q1, and check for 10 kHz oscillator injection, which should be at a level of at least 50 MV. If this injection is absent, refer to the Crystal Oscillator Test procedure.

c. Connect RF VTVM to the base of Q2, and check for the Q1 mixer product through FL1. The signal level should be at about 40 MV. If this product signal is absent, the problem may be in the Q1 mixer stage, the filter, or in the 10 kHz spectrum generator. Refer to the Divider/Spectrum Generator Test Procedure to check the 10 kHz spectrum generator.

d. Disconnect P12, connect RF VTVM to the emitter of Q4, and check for Q2 output through T1. This signal should be at a level of at least 70 MV. Reconnect P12.

e. Connect RF VTVM to the base of Q3, and check for 1 kHz Oscillator injection, which should be at a level of at least 30 MV. Refer to Crystal Oscillator Test Procedure if this injection is absent.

f. Disconnect P13. Connect RF VTVM to the base of Q4, and check for Q3 mixer product through FL2. This signal should be at a level of at least 3 MV. If this product signal is absent, the problem may be in the Q3 mixer stage, filter FL2, or in the 1 kHz spectrum generator. Refer to the Divider/Spectrum Generator Test Procedure to check the 1 kHz spectrum generator. Reconnect P13.

g. With meter connected as in step f, pull out the 1 kHz FREQUENCY knob. This disables Q3

and turns on Q6. Check for at least 3 MV of 1.1015 MHz oscillator output from Q6. Return the 1 kHz knob to the in position when through with test.

h. Connect RF VTVM to the base of amplifier Q5, and check mixer product through FL3. The signal level should be at least 30 MV.

i. Unplug P17, connect RF VTVM to J17, and check for 455 kHz output from Q5 and T2. The output level should be between 140 and 280 MV. Reconnect P17.

j. Connect RF VTVM to junction of J16 and R32. Connect dummy load to antenna connector. Set FUNCTION switch on AM, and key the transceiver. Check for carrier reinsert output of about 5 MV when not speaking, and check for an increase in output with modulation. The AM/XMIT line (P18-C) should be at +12 VDC on AM transmit and grounded during any other conditions. If the carrier re-insert level does not vary with modulation, the problem may lie in the ACC circuits. Refer to the ACC Test Procedure.

6.12.2 455 kHz ERROR MIXER VOLTAGE MEASUREMENTS.

DC and AC voltage measurements are given for the 455 kHz Error Mixer stages in table 6.5. Use any receiving mode except as indicated.

Table 6.5 - 455 kHz Error Mixer Voltage Chart

STAGE	EMITTER	BASE	COLLECTOR	NOTES
DC VOLTAGES				
Q1	6.8 V	6.6 V	0 V	
Q2	7.2 V	7.0 V	0 V	
Q3	7.2 V	7.0 V	0 V	
Q4	7.4 V	6.8 V	0 V	
Q5	7.6 V	7.1 V	0 V	
Q6	12 V	12 V	0 V	AM receive using VFO tuning
Q7	7 V	6.8 V	0.24 V	AM transmit mode
AC VOLTAGES				
Q1	37 MV	3.3 MV	2.8 V	P13 disconnected
Q1	40 MV	70 MV	6 V	HP-410B used at collector
Q2	5.8	68 MV	310 MV	
Q3	4 MV	2 MV	240 MV	P12 disconnected
Q3	33 MV	110 MV	220 MV	P15 disconnected
Q3	7 MV	100 MV	2.9 V	
Q4	1.5 MV	4.8 MV	140 MV	P13 & P14 disconnected
Q4	90 MV	4.0 MV	3.0 MV	P12 & P15 disconnected
Q4	83 MV	3.4 MV	2.8 MV	
Q5	7 MV	80 MV	1.9 V	
Q6	120 MV	1.2 MV	980 MV	CW receive Mode, using VFO tuning
Q7	2.7 MV	11 MV	360 MV	AM Xmit mode



6.12.3 455 KHz ERROR MIXER ALIGNMENT PROCEDURE.

a. Set the transceiver for USB reception at 2.555 MHz.

b. Connect RF VTVM to collector of Q2. Tune C3 and T1 for peak indication of about 350 mV.

c. Reconnect RF VTVM to junction of T2 and C22. Tune C11, C25, and T2 for peak indication.

d. Reconnect RF VTVM to base of Q5. Set slug of T4 for minimum inductance. Pull out the 1 kHz FREQUENCY knob. Turn slug clockwise until a reading is obtained on the RF VTVM indicating oscillation. Turn slug an additional half turn and push in the 1 kHz FREQUENCY knob. Observe the RF VTVM and pull out the 1 kHz FREQUENCY knob. A reading should be obtained immediately. If there is a delay before output is obtained, readjust T4.

6.12.4 455 KHz ERROR MIXER ASSEMBLY REMOVAL AND INSTALLATION PROCEDURES.

6.12.4.1 Removal From Transceiver.

a. Unplug coaxial cables 12, 13, 14, and 15 from PC board.

b. Remove 2 screws securing PC board to chassis.

c. Pull PC board up and out until coaxial cable connector P17 is accessible.

d. Unplug connector P17 and lift PC board on up and out until coaxial connector at P16 is accessible.

e. Unplug coaxial connector P16, and remove PC board.

6.12.4.2 Installation In Transceiver.

a. Plug coaxial cables 16 and 17 into J16 and 17 respectively on PC board.

b. Insert lower right edge of PC board into guide on right edge of PC board connector on chassis, and properly aligning six mating prongs on each connector, press PC board into position on chassis.

c. Install two screws, one at each upper corner, securing PC board to chassis.

6.13 TRANSLATOR.

Refer to figures 8.9 and 8.10 for parts location and schematic diagrams.

6.13.1 TRANSLATOR TEST PROCEDURE.

a. Remove the shield from above Q1 on the Translator assembly.

b. Connect the signal generator to the antenna connector, and tune it and the transceiver for 2.5 MHz USB reception. Set the signal generator for 10 MV output. Disconnect microphone to prevent accidental keying.

c. Connect RF VTVM to the emitter of Q1, and check for MHz injection. It should be about 50 MV. Refer to Crystal Oscillator Test Procedure if results are negative.

d. Connect RF VTVM to the base of Q2, disconnect the 100 kHz injection at P7, and check for signal level of about 120 MV from Q1 and FL1. Reconnect P7 when finished.

e. Connect RF VTVM to the emitter of Q2, and check for 100 kHz injection. It should be a minimum of 70 MV. Refer to Crystal Oscillator Test Procedure if results are negative.

f. Connect RF VTVM to the base of Q3, disconnect the 11.6 MHz injection at P9, and check for signal level of about 140 MV from Q2 and FL2. Reconnect P9 when finished.

g. Connect RF VTVM to the emitter of Q3, and check for 11.6 MHz injection. It should be a minimum of 70 MV. Refer to the 11.6 MHz Error Mixer test procedure if results are negative.

h. Disconnect P10, connect RF VTVM to J10, and check for signal output (approximately 700 MV). Reconnect P10 when finished.

If all of the stages check out to be good, and the Translator operates on receive, but not on transmit, the problem probably lies in the switching diode circuitry and the associated T/R and R/T lines. Disconnect the signal generator and connect the dummy load to test these.

The T/R line E63 should be at +12 VDC on transmit and grounded on receive. The R/T line E62 should be +12 VDC on receive and grounded on transmit. These control lines forward or reverse (back) bias diodes to "steer" the signals on their respective receive or transmit paths.

Figure 6-23 shows the polarity of the diodes used and shows the conditions which cause forward and reverse bias in a simplified circuit. The signal flows through the forward biased diodes.

CR1, CR3, CR5, CR7, CR10, CR12, CR15 and CR16 should be forward biased on receive. CR2, CR4, CR6, CR8, CR9, CR11, CR13 and CR14 should be forward biased on transmit. A DC VTVM can be used to determine if a diode is forward biased; the anode should be approximately 0.2 volts more positive than the cathode.

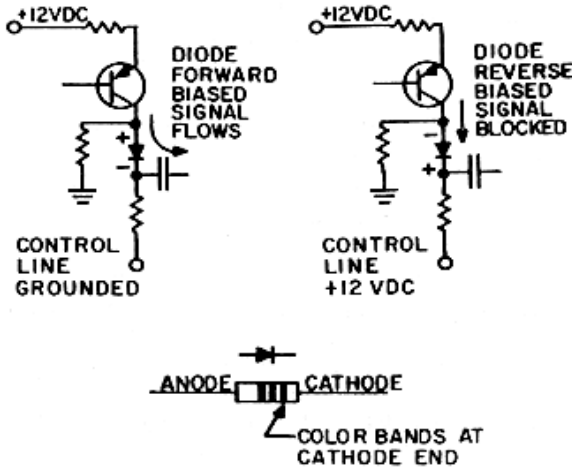

Figure 6.23 — Switching Diodes

6.13.2 TRANSLATOR VOLTAGE MEASUREMENTS.

DC and AC voltage measurements are given for the Translator stages in table 6.6. AC voltages are taken with TRANSMIT AUDIO fully clockwise (but not in TUNE position).

6.13.3 TRANSLATOR ALIGNMENT PROCEDURE.

- a. Tune transceiver to receive CW on 2.444 MHz.
- b. Connect signal generator to antenna connector. Set generator for 2.444 MHz.

c. Connect Audio VTVM across the speaker in the transceiver.

d. Set signal generator output to give low S-meter reading on transceiver.

e. Peak C2, C13, C19, and C22 for highest reading.

f. Remove signal generator, and connect dummy load to antenna connector.

g. Tune transceiver for CW transmission at 2.444 MHz. Set TRANSMIT AUDIO control for about 50 watts output. Peak T1, C27, C20, and C10 for highest panel meter reading.

h. Repeat steps a through g.

Table 6.6 — Translator Voltage Chart

STAGE	EMITTER	BASE	COLLECTOR	NOTES
DC VOLTAGES				
Q1	6.8 V	6.6 V	1.6 V	
Q2	6.4 V	6.2 V	0.8 V	
Q3	6.2 V	6.0 V	0.65 V	
AC VOLTAGES (XMIT, CW, Drive into ALC)				
Q1	90 MV	35 MV 125 MV	1.0V 170 MV	J32 disconnected
Q2	98 MV	42 MV 44 MV	530 MV 40 MV	J7 disconnected
Q3	90 MV	14 MV 30 MV	125 MV 15 MV	J9 disconnected

6.13.4 TRANSLATOR ASSEMBLY REMOVAL AND INSTALLATION PROCEDURES.

6.13.4.1 Removal From Transceiver.

- a. Make sure unit is off. Remove two screws securing shield in upper front corner of PC board and remove shield.
- b. Unplug coaxial cables 7, 8, 9, 10, and 11 from PC board.
- c. Unsolder the black wire to ground lug on partition near J8, connected to E190.



d. Unsolder the wires from E61, E62, E63 and E188.

e. Remove the two Phillip screws at the bottom corners of PC board.

f. Remove two shield mounting posts at upper corners of PC board and remove PC board by sliding up and out.

6.13.4.2 Installation In Transceiver.

a. Make sure unit is off. Insert assembly into position on transceiver chassis, and install retaining screw in each lower corner of PC board.

b. Install shield mounting post securing each upper corner of PC board.

c. Solder green/black wire to terminal E63 (see figure 8.9).

d. Solder the two white/green wires to terminal E62.

e. Solder white/brown wire to terminal E61.

f. Solder black outer shield lead from coaxial cable number 11 to ground lug on chassis near J11.

g. Solder black ground wire from ground lug on partition near J8 to terminal E190.

h. Solder black ground wire from ground lug on partition near J9 to terminal E188.

i. Connect coaxial cables 7 through 11 to jacks J7 through J11, respectively, on PC board.

j. Install shield and two screws securing shield in upper front corner of PC board.

6.14 IF AMPLIFIER.

Refer to figures 8.11 and 8.12 for parts location and schematic diagrams.

6.14.1 IF AMPLIFIER TEST PROCEDURE.

6.14.1.1 Receive IF Stages.

When testing the receive IF stages, the assembly should be removed from its mounted position; (refer to paragraph 6.14.4) and all of its connections

except the E167 input should be made by reconnecting cables. Make ground connections to both the assembly mounting brackets. The transceiver should be set to receive. The noise limiter should be turned off, and the RF GAIN control should be set to maximum clockwise position.

a. Connect signal generator, set for 455 kHz output, to E167. Connect Heterodyne Voltmeter, set for 455 kHz, to E167, and set signal generator for 18 μ V reading on Heterodyne Voltmeter.

b. Connect Heterodyne Voltmeter to the base of Q2, and check for a reading of about 50 μ V.

c. Connect Heterodyne Voltmeter to the base of Q3, and check for a reading of about 200 MV - 600 MV.

d. Connect Heterodyne Voltmeter to the base of Q4, and check for a reading of about 300 - 800 μ V. (This value is dependent on the setting of R16).

e. Connect Heterodyne Voltmeter to the base of Q5, and check for a reading of about 120 μ V.

f. Connect Heterodyne Voltmeter to the junction of L1 and the collector of Q5, and check for a reading of about 14 MV.

If any of these readings are low, it indicates a faulty IF amplifier stage at the point just prior to the point where the reading was low.

g. Connect Heterodyne Voltmeter to E167. Increase signal generator output to obtain 58 MV reading on Heterodyne Voltmeter.

h. Connect Heterodyne Voltmeter to the junction of L1 and the collector of Q5. If the AGC circuits are operating properly, the IF output at this point should now measure about 100 MV.

6.14.1.2 AGC Circuits.

If it has been determined under steps 6.14.1.1 g and h that the AGC circuits do not control the gain of the receive IF stages properly, proceed with these tests. Connect signal generator to E167.

a. Set signal generator for 1 MV reading on Heterodyne Voltmeter connected to the junction of R40, R41, and C21 (Q7 circuit).



b. Connect Heterodyne Voltmeter to the base of Q8, and check for a reading of about 15 MV.

c. Connect DC VTVM to the base of Q9, and check for a reading of about +1.4V.

d. Connect DC VTVM to the base of Q10, and check for a reading of about 3.5V.

e. Connect DC VTVM to the junction of L3 and C37, and check for a reading of about +3V.

If the AGC circuits seem to be operating, but the readings are low, check the setting of R39 according to the IF Amplifier Alignment Procedure.

6.14.1.3 Transmit IF Stage.

When testing the transmit IF stage, the assembly should be removed from its mounted position, and all of its connections except the E167 output should be made by reconnecting cables. Ground connections should be made to both the assembly mounting brackets. A 390 ohm load resistor should be connected between E167 and ground. The transceiver should be set for CW operation and keyed for tests.

a. Connect Heterodyne Voltmeter, set for 455 kHz, to the junction of R37 and C25 (Q6 circuit). Set TRANSMIT AUDIO control for 4 MV reading at this test point.

b. Connect Heterodyne Voltmeter across 390 ohm output load, and check for 135 MV reading.

When test and repairs are completed, reinstall the assembly in the transceiver and re-connect all leads.

6.14.2 IF AMPLIFIER VOLTAGE MEASUREMENTS.

Dc and AC voltage measurements for the IF Amplifier stages are given in table 6.7.

6.14.3 IF AMPLIFIER ALIGNMENT PROCEDURE.

6.14.3.1 Receive IF Stages.

a. Set transceiver to receive with noise limiter turned off. Turn RF GAIN control to maximum clockwise position.

b. Remove IF Amplifier assembly from chassis, and reconnect all cables except to the E167 input terminal. Make ground connections to both assembly mounting brackets.

Table 6.7 – IF Amplifier Voltage Chart

STAGE	EMITTER	BASE	COLLECTOR	NOTES
DC VOLTAGES				
Q1	8 V	7.8 V	0 V	(a)
Q2	7.8 V	7.6 V	0 V	(a)
Q3	6.8 V	6.4 V	0 V	(a)
Q4	5.4 V	5.0 V	0 V	(a)
Q5	5.6 V	5.2 V	.06 V	(a)
Q6	8.4 V	8.2 V	0 V	XMIT, CW (b)
Q7	9.8V	9.6 V	0 V	(a)
Q8	10.5 V	10 V	0 V	(a)
Q9	0 V	0 V	12 V	(a)
Q10	.3 V	0 V	12 V	(a)
AC VOLTAGES				
Q1	(c)	(c)	3.0 MV	(d)
Q2	(c)	(c)	17 MV	(d)
Q3	(c)	7.2 MV	520 MV	(d)
Q4	3.3 MV	7.0 MV	450 MV	(d)
Q5	1.9 MV	2.2 MV	50 MV	(d)
Q6	8 MV	8.5 MV	1.2 V	XMIT, CW, Drive into ALC (e)
Q7	2.3 MV	1.3 MV	63 MV	(d)
Q8	3.2 MV	14 MV	2.6 V	(d)
Q9	2 MV	1.2 V	22 MV	(d)
Q10	2 MV	2 MV	7.7 MV	(d)
E167				280 MV output (e)

(a) Emitter, base, and collector voltages zero in transmit mode.

(b) Emitter, base, and collector voltages zero in receive mode.

(c) Below noise level of Boonton 91C VTVM.

(d) Receive, CW, signal generator connected to E167, output level adjust for S6 reading.

(e) Signal generator disconnected, TRANSMIT AUDIO fully clockwise (not in TUNE position).

c. Connect Heterodyne Voltmeter, set for 455 kHz, to the junction of L1 and the collector of Q5. Connect signal generator, set for 455 kHz, to the E167 input terminal. As tuning progresses, set the attenuator on the signal generator for a signal level high enough to obtain a meter indication to tune by, but never over the level necessary to obtain a 100 MV output reading.

d. Ground P20 pin F with a clip lead and set signal generator output to 50 uV. Adjust each of the IF transformers beginning with T1 and ending with T4, for maximum indication. The output should now read 27 MV±5MV. If the signal is not within this range, R16 should be adjusted. IF reading is within this range, R16 should not be adjusted as it is a factory-set adjustment. Repeat this paragraph until further adjustment of T1-T4 produces no increase in gain. Remove ground from pin F when procedure is completed.

6.14.3.2 AGC Stages.

The AGC stages should be aligned under conditions described in section 6.14.3.1 and only after the receive IF stages are aligned.



a. Connect DC VTVM to the junction of L3 and C37. Set signal generator, when tuning, to obtain a meter reading to tune by but never over 2 volts on the VTVM.

b. Adjust T5 and T6 for maximum meter reading.

c. Connect Heterodyne Voltmeter to terminal E167, and set signal generator for reading of 18 μ V.

d. Connect Heterodyne Voltmeter to the junction of L1 and the collector of Q5, and measure the IF output level. Make a note of this reading.

e. Connect Heterodyne Voltmeter as in step c, and set signal generator for 58 MV meter reading.

f. Connect Heterodyne Voltmeter as described in step d. Adjust R39 for an output meter reading 7 times the reading obtained under step d.

g. Repeat steps c through f until no further adjustment is necessary.

6.14.3.3 Transmit IF Stage.

a. Remove IF Amplifier assembly from chassis, and reconnect all cables except to the E167 output terminal. Connect a 390 ohm resistor from the E167 output terminal to ground.

b. Set transceiver to transmit on CW. There should be no transmitter output because the IF amplifier output is disconnected. Key transmitter when necessary for test.

c. Connect Heterodyne Voltmeter, set for 455 kHz, across output load resistor at E167. When tuning, turn TRANSMIT AUDIO control up enough to get an indication on the meter to tune by, but never over 70 MV.

d. Adjust T7 for maximum output.

e. Connect Heterodyne Voltmeter to the junction of C25 and R37. Set TRANSMIT AUDIO control for 4 MV IF input.

f. Connect Heterodyne Voltmeter across 390 ohm output load resistor. If the IF stage is aligned properly, the output at E167 should be approximately 135 MV when the input is 4 MV.

g. Remove and disconnect ALC assembly from chassis. Connect +3 volt power supply to the junction of C40 and CR5 on the IF Amplifier assembly.

h. Set ALC potentiometer, R35 on the IF Amplifier assembly so that the IF output just starts to decrease.

i. Re-install the ALC and IF Amplifier assemblies. Remove dummy load resistor from E167, and reconnect all leads.

6.14.4 IF AMPLIFIER ASSEMBLY REMOVAL AND INSTALLATION PROCEDURES.

6.14.4.1 Removal From Transceiver.

a. Remove 455 kHz Error Mixer and Audio/Modulator assemblies (see paragraph 6.12 and 6.16).

b. Remove two screws, one under each of above boards, fastening mounting bracket in each upper corner of IF Amplifier PC board to chassis.

c. Unsolder lead from capacitor C57 (on FUNCTION switch) to terminal E167.

d. Remove three screws securing lower edge of PC board to chassis, and pull PC board out of chassis until coaxial connector P22 and eight-terminal connector P20 are accessible.

e. Unplug P22 and P20 and remove PC board.

6.14.4.2 Installation In Transceiver.

a. Plug eight-terminal cable connector P20 into mating connector on PC board, properly aligning the eight mating terminals before engaging them.

b. Plug coaxial cable number 22 into J22 on PC board.

c. Insert PC board into position in chassis and install two screws, one below 455 kHz Error Mixer and one below Audio/Modulator, through chassis into mounting brackets on upper corners of PC board.

d. Install three screws securing lower edge of PC board to chassis.

e. Solder lead from capacitor C57 on FUNCTION switch to terminal E167.

f. Install 455 kHz Error Mixer and Audio/Modulator assemblies (see paragraphs 6.12 and 6.15).



6.15 AUDIO/MODULATOR.

Refer to figures 8.13 and 8.14 for parts location and schematic diagrams.

6.15.1 AUDIO/MODULATOR TEST PROCEDURE.

Several possible symptoms of faulty sections of the Audio/Modulator Assembly can be found merely by operating the transceiver.

If the transceiver only operates in AM receive, the problem may lie in the SSB modulator/detector, CR10, 11, 12, 13; or the injection amplifier, Q9. Conversely if the transceiver fails to operate only in AM receive, the problem may lie in the AM detector stage, Q3. If the transceiver will operate except in CW transmit, the problem probably lies in the CW oscillator stage, Q5. If the transceiver will not key and or hold properly in CW transmit, the problem probably lies in the CW hold stage, Q6. If the transceiver will not transmit audio, but receives SSB properly, the problem probably lies in the transmit audio stage, Q4. If there is an audible sidetone from the speaker in CW transmit, but full output cannot be obtained, the problem may be in the SSB modulator/detector CR10, 11, 12, 13; or the injection amplifier, Q9. If the CW transmit output is as it should be, but the sidetone is not audible in the speaker, the problem probably lies in the audio output stages, Q7 and Q8.

The SSB modulator/detector depends on the 455 kHz injection at J24. The RF VTVM can be connected to P24 to check for this injection. Other necessary inputs to the Audio/Modulator assembly are the T/R, R/T, and AM/RT lines. The T/R line should be at +12 VDC on transmit and ground on receive. The R/T line should be at +12 VDC on receive and ground on transmit. The AM/RT line should be at +12 VDC on AM receive and ground on all other modes.

6.15.2 AUDIO/MODULATOR VOLTAGE MEASUREMENTS.

DC and AC voltage measurements for the Audio/Modulator stages are given in table 6.8.

6.15.3 AUDIO/MODULATOR ALIGNMENT PROCEDURE.

a. Connect dummy load to antenna connector, and connect the RF probe of an RF VTVM across dummy load.

Table 6.8 – Audio/Modulator Voltage Chart

STAGE	EMITTER	BASE	COLLECTOR	NOTES
DC VOLTAGES				
Q3	3 V 0 V	2.8 V 0 V	0 V 0 V	(a)
Q4	10 V 10 V	10 V 10 V	3 V 3 V	(a)
Q5	8 V	7.4 V	3 V	
Q6	13 V 0.9 V	13 V 0.6 V	0 V 0 V	(a)
Q7	9.3 V	9.1 V	4 V	
Q8	4.8 V	4.7 V	0 V	
Q9	2.3 V	1.6 V	0 V	
Q10	6 V 0 V	5.3 V 4.9 V	0 V 0 V	(a)
AC VOLTAGES				
Q3	1.0 MV	2.5 MV	670 MV	(b)
Q4	10 MV	12 MV	35 MV	(c) audio
Q5	0 V	x	2.2 V	audio
Q6	0 V	0V	0 V	(a)
Q7	6 MV	10 MV	460 MV	(d) audio
Q8	460 MV	460 MV	0 V	(d) audio
Q9	185 MV	230 MV	0 V	
Q10	43 MV	43 MV	0.1 V	(d)

- (a) Transmit mode, CW
 (b) 300 uv, 30% modulated 2.555 MHz input to antenna connector. AM receive mode.
 (c) CW transmit mode, 2.555 MHz at ALC threshold.
 (d) 100 uv unmodulated 2.555 MHz input to antenna connector. LSB or USB receive mode.
 x Not significant.

b. Tune the transceiver to transmit 50 watts on CW, and adjust T7 for maximum output. This adjustment will produce a very small peak in output voltage, and may occur at an extreme of the tuning cup travel. (Caution: the tuning cup of T7 should not be forced at its inward end-of-travel point, or withdrawn more than 3 turns from that point.)

c. If the SSB modulator requires balancing, turn the TRANSMIT AUDIO control to its counterclockwise stop, and set the mode switch to USB or LSB. The RF Voltmeter will now read residual carrier. Null the carrier by adjusting R56 and C58, alternately, until no further reduction is possible.

d. Set transceiver to receive on USB or LSB. Connect signal generator to the antenna connector, and tune it for a low level signal, at the receiving frequency.

e. Connect Audio VTVM across speaker, and tune T8 for highest reading. This adjustment will produce a small peak in output voltage, and may occur at an extreme end of the tuning cup travel. (Caution: the tuning cup of T8 should not be forced at its inward end-of-travel point, or withdrawn more than 3 turns from that point.)

f. Set transceiver to receive on AM. Connect signal generator to the antenna connector, and tune it for a low level signal, at the receiving frequency, with 30% tone modulation.

g. Connect Audio VTVM across speaker, and tune T4 for highest reading.

6.15.4 AUDIO/MODULATOR ASSEMBLY REMOVAL AND INSTALLATION PROCEDURES.

6.15.4.1 Removal From Transceiver.

a. Remove two screws securing PC board to chassis.

b. Pull PC board up and out until coaxial cable connectors P24 and P25 are accessible.

c. Unplug P24 and P25, and remove PC board from chassis.

6.15.4.2 Installation in Transceiver.

a. Plug coaxial cables number 24 and 25 into J24 and J25, respectively on PC board.

b. Insert PC board into position on chassis, mating 23 terminal connector P23 with jack J23 on chassis.

c. Install two screws with washers on upper corners of PC board, securing it to chassis.

6.16 VFO.

Refer to figures 8.15 and 8.16 for parts location and schematic diagrams.

6.16.1 VFO TEST PROCEDURES.

a. Tune transceiver to receive USB on 2.555 MHz.

b. On the 11.6 MHz Error Mixer assembly, unplug P42 (10 kHz injection), and connect the RF VTVM to the emitter of Q4 (accessible at R19). Pull the 1 kHz FREQUENCY knob out. The output from the VFO should be approximately 50 MV. If voltage output is good proceed to (c), if missing proceed to (d).

c. Connect a VTVM to the emitter of Q4 of the 11.6 Error Mixer board. Connect the frequency counter to the amplifier output on the VTVM. Check the VFO frequency at dial settings 0 (798.5

kHz) and 9 (789.5 kHz). If not correct refer to alignment procedure (paragraph 6.16.3).

NOTE

If VFO operates properly, but the transceiver does not operate with the 1 kHz FREQUENCY control pulled out, the problem may lie in the 1.1015 MHz oscillator stage, Q6, on the 455 kHz Error Mixer assembly. This oscillator must be operating properly when the VFO is used. Refer to table 6.5 for Q6 AC voltages.

d. Measure the DC voltages of the VFO and compare with table 6.9. Any deviations from normal indicate bias network or transistor problems. If voltages are normal, the trouble is in the signal or feedback circuits.

e. Connect RF VTVM to the junction of R5-R6 on VFO assembly. This reading should be about 30 MV. If there is no output at R5-R6, adjust R7 fully in each direction. Normally, R7 is set for 35 MV at the collector of Q3. If oscillations do not occur and all DC measurements are good, proceed to step f.

f. Unsolder and remove C5 (.1 uF), and use C5 to connect a signal generator, set for 40 MV output at 790 kHz, to the base of Q1. This will allow interruption of the feedback loop and allow checking the stages as amplifiers. Use the AC voltages in table 6.9 to help locate faulty stage and component.

g. Make repairs, and then perform steps e and then c.

6.16.2 VFO VOLTAGE MEASUREMENTS.

DC and AC voltage measurements for the VFO stages are given in table 6.9.

6.16.3 VFO ALIGNMENT PROCEDURE.

a. If the VFO tuning capacitor and drive assembly is mechanically out of adjustment, loosen the two set-screws on the capacitor drive gear, and set the capacitor plates half meshed with the 1 kHz knob on position 0. Tighten the set screws.



Table 6.9 – VFO Voltage Chart

STAGE	EMITTER	BASE	COLLECTOR	NOTES
DC VOLTAGES (a)				
Q1	4.6 V	4.4 V	0 V	
Q2	5 V	4.6 V	1.6 V	
Q3	7.4 V	7.2 V	.1 V	
Q4	7.3	7 V	0 V	
AC VOLTAGES (a)				
Q1	40 MV	40 MV	0 V	
Q2	1 MV	40 MV	1.5 V	
Q3	50 MV	105 MV	40 MV	
Q4	3 MV	62 MV	4.0 V	

(a) With 1 kHz oscillator knob pulled out.

b. Connect the RF VTVM to the collector of Q4. Push the 1 kHz knob in, and set it on position 4. Adjust T1 for peak meter reading, using the signal from the 1 kHz Oscillator to tune by.

c. Connect RF VTVM to the collector of Q3 with 1 kHz knob pulled out in position 4, set R7 for 40 MV of feedback to Q1. Disconnect VTVM.

d. Remove P42 from its jack on the 11.6 MHz Error Mixer assembly. Connect the VTVM to the emitter of Q4 on that assembly. Connect the Frequency Counter to the amplifier output on the VTVM.

e. Turn the 1 kHz knob to the 0 position.

f. Adjust C1 for a counter reading of 798.5 kHz.

g. Set the 1 kHz knob, with knob pulled out, to the 9 position.

NOTE

The core in L1 is delicate! L1 is a factory adjustment. It should not be tampered with unless sufficient tuning range is not available with L2, and then adjust with care, sliding alignment tool easily into slug without pressure. Five to ten degree adjustments should be sufficient.

h. Adjust the fine tuning coil, L2, for a counter reading of 789.5 kHz.

i. Repeat steps e through h until the VFO tracks properly on these frequencies.

6-32

NOTE

It is a bit easier to follow steps e through h using a comparison of beat tones instead of the frequency counter. Obtain a beat tone with 1 kHz switch in and align vfo for the same beat tone with the 1 kHz. knob pulled out, adjusting C1 for low kHz. switch settings and L2 for high kHz. switch settings. When making these adjustments it is advantageous to overcorrect L2 and C1 (rather than simply adjusting to beat tone) since these controls interact. Leave P42 connected for this procedure.

j. Replace P42, and disconnect test equipment.

6.16.4 VFO ASSEMBLY REMOVAL AND INSTALLATION PROCEDURES.**6.16.4.1 Removal From Transceiver.**

a. Unsolder black wire between PC board and VFO tuning capacitor C4, from C4.

b. Remove screw in each upper corner of PC board, and remove board.

6.16.4.2 Installation In Transceiver.

a. Insert PC board in position on chassis, properly aligning five mating terminals on connectors on PC board and chassis before engaging them; and install two screws, one in each upper corner, securing board to chassis.

b. Solder black lead from PC board to VFO tuning capacitor C4. Run wire alongside metal bracket behind VFO assembly for as long as slack in wire allows.

6.17 CRYSTAL OSCILLATORS.

Refer to figures 8.17 through 8.24 for Crystal Oscillator parts location and schematic diagrams.

6.17.1 CRYSTAL OSCILLATOR TEST PROCEDURES.

There are three common failures for the crystal oscillators. The first is loss of output on one or more frequencies and not on the rest. This would probably be due to switch contacts, defective crys-



tals or low gain transistors. The second and third failures usually result in no output, and are due to a failure of either the oscillator or the buffer amplifier. Either the oscillator no longer drives the buffer amplifier, or the buffer amplifier fails and overloads the oscillator. For the MHz and 100 kHz oscillators, set a signal generator for a frequency near the oscillator frequency, and inject 750 MV of signal at the crystal terminals through a 1 K resistor, and trace the signal through the oscillator and buffer amplifier circuits to locate the defective component. Use the voltage table for the particular oscillator being checked.

6.17.2 CRYSTAL OSCILLATOR VOLTAGE MEASUREMENTS.

DC and AC voltage measurements for the Crystal Oscillators are given in tables 6.10 through 6.13.

6.17.3 CRYSTAL OSCILLATOR ALIGNMENT PROCEDURES.

Necessary alignment procedures for the four Crystal Oscillators are given in paragraphs 6.17.3.1 through 6.17.3.4.

6.17.3.1 MHz Oscillator Alignment Procedure. Use an insulated tuning tool.

a. Set the transceiver to receive.

b. Remove the shield from over Q1. Connect the Frequency Counter, through a .01 uF capacitor to the emitter of Q1 on the Translator assembly.

c. Adjust C5 for approximate frequency readings, according to the chart on the schematic diagram, in 1000 kHz knob positions 2 through 7, 10, 12, and 14. The setting of C5 will be a compromise to make all of the frequencies as close as possible, so the process should be repeated, if necessary.

d. With the 1000 kHz knob set for 13, adjust C4 for proper frequency according to chart.

e. With 1000 kHz knob set for 11, adjust C3 for proper frequency.

f. With 1000 kHz knob set for 9, adjust C2 for proper frequency.

g. With 1000 kHz knob set for 8, adjust C1 for proper frequency.

Table 6.10 – MHz Oscillator Voltage Chart

STAGE	EMITTER	BASE	COLLECTOR	NOTES
POSITIVE DC VOLTAGES TO GROUND				
Q1	6.3 V	5.9 V	0.75 V	
Q2	0.06 V	0 V	4.9 V	
Q3	4.6 V	5.2 V	10.5 V	
Q4	4.6 V	5.2 V	11.0 V	

Table 6.11 – 100 kHz Oscillator Voltage Chart

STAGE	EMITTER	BASE	COLLECTOR	NOTES
DC VOLTAGES				
Q1	5.8 V	6.1 V	2.4 V	
Q2	4.4 V	5.2 V	10 V	
AC VOLTAGES				
Q1	290 MV	0.7 V	2.7 V	
Q2	875 MV	850 MV	890 MV	
DIAL	E23	E18		
AC VOLTAGES				
0	90 MV	35 MV		
1	90 MV	35 MV		
2	90 MV	35 MV		
3	89 MV	35 MV		
4	89 MV	34 MV		
5	88 MV	34 MV		
6	87 MV	35 MV		
7	85 MV	34 MV		
8	83 MV	34 MV		
9	82 MV	34 MV		

Table 6.12 – 10 kHz Oscillator Voltage Chart

STAGE	EMITTER	BASE	COLLECTOR	NOTES
DC VOLTAGES				
Q1	10 V	10.2 V	2.4 V	
Q2	2.6 V	2.4 V	7.6 V	
AC VOLTAGES				
Q1	750 MV	6 MV	1.7 V	
DIAL	E30	E35		
AC VOLTAGES				
0	73 MV	6.6 MV		
1	73 MV	6.8 MV		
2	74 MV	6.9 MV		
3	75 MV	6.7 MV		
4	76 MV	6.6 MV		
5	77 MV	6.8 MV		
6	78 MV	6.4 MV		
7	79 MV	6.9 MV		
8	80 MV	6.9 MV		
9	80 MV	6.0 MV		



Table 6.13 — 1 kHz Oscillator Voltage Chart

STAGE	EMITTER	BASE	COLLECTOR	NOTES
DC VOLTAGES				
Q1	6.4 V	5.8 V	2.3 V	
Q2	3.0 V	2.3 V	8.7 V	
Q3	9.9 V	10.2 V	6.1 V	
Q4	9.9 V	10.2 V	6.1 V	
Q5	3.0 V	3.6 V	12.5 V	
Q6	3.0 V	3.6 V	12.5 V	
AC VOLTAGES				
Q1	1.0 V	70 MV	1.5 V	
Q2	1.7 V	1.75 V	2.20 V	
Q3	95 MV	1.3 V	3.0 V	
Q4	95 MV	1.2 V	3.0 V	
Q5	1.2 V	0.93 V	20 MV	
Q6	1.2 V	0.95 V	20 MV	
DIAL	E42	E47		
AC VOLTAGES				
0	122 MV	61 MV		
1	122 MV	61 MV		
2	122 MV	61 MV		
3	121 MV	61 MV		
4	121 MV	61 MV		
5	121 MV	61 MV		
6	120 MV	61 MV		
7	120 MV	60 MV		
8	120 MV	60 MV		
9	120 MV	60 MV		

h. Remove Frequency Counter. Connect 52 ohm, 200 watt dummy load to the transceiver antenna connector. Tune the transceiver to transmit CW on 13.005 MHz. Then turn the TRANSMIT AUDIO to the counterclockwise stop.

i. Connect Heterodyne Voltmeter, set for 12.741 MHz, to E158 on RF Amplifier board (162-0260). The Heterodyne Voltmeter will indicate the strength of a spurious signal at 12.741 MHz when transmitting. Do not turn the TRANSMIT AUDIO control up, since the normal 13.005 MHz CW signal is undesired for this test.

j. With the transceiver keyed, carefully adjust C4 for a null indication on the Voltmeter at the spurious frequency. Do not turn C4 to a position which gives no indication, since this may stop the oscillation of the crystal. When adjusted properly, a crystal in the RF Amplifier assembly traps the spurious signal. C4 is adjusted such that the frequency of the spurious signal falls at the trap crystal frequency and a null occurs. The same process will also be used for nulling three other spurious frequencies.

k. Tune the transceiver on CW for 11.915 MHz transmission. Turn the TRANSMIT AUDIO control all the way down. Tune the Heterodyne Voltmeter to the 12.494 MHz spurious signal. Adjust C3 for a null as before.

l. Tune the transceiver on CW for 9.005 MHz transmission. Turn the TRANSMIT AUDIO control all the way down. Tune Heterodyne Voltmeter to the 8.247 MHz spurious signal. Adjust C2 to null this spurious signal.

m. Tune the transceiver to transmit CW on 8.915 MHz. Turn the TRANSMIT AUDIO control all the way down. Tune the Heterodyne Voltmeter to the 9.247 MHz spurious signal. Adjust C1 to null this spurious signal.

n. Remove the test circuit and the dummy load.

6.17.3.2 100 kHz Oscillator Alignment Procedure.

a. Tune the transceiver to receive.

b. Connect Frequency Counter, through a .01 uF capacitor, to E23 on the 100 kHz Oscillator assembly.

c. Adjust C3 to bring the oscillator frequencies, on all positions, within 200 cps of the frequencies shown in the schematic diagram for the corresponding dial positions. If all but one crystal oscillates on the correct frequency, the crystal may be faulty.

6.17.3.3 10 kHz Oscillator Alignment Procedure.

No alignment necessary.

6.17.3.4 1 kHz Oscillator Alignment Procedure.

No alignment necessary.

6.17.4 CRYSTAL OSCILLATOR ASSEMBLIES REMOVAL AND INSTALLATION PROCEDURES.

6.17.4.1 General.

Removal of the MHz Oscillator Assembly requires prior removal of the RF Amplifier assembly. Some repairs to the PC boards are possible without removal of the oscillator assembly. For this reason,



localization of a defect to one of these assemblies should be accomplished as thoroughly as possible before removal.

6.17.4.2 MHz Oscillator Assembly.

a. Removal and Disassembly.

1.) Remove RF Amplifier assembly (See paragraph 6.9.4).

2.) Remove ground lug on shield between MHz and 100 kHz Oscillator assemblies.

3.) Loosen two Allen screws in control knob, and remove control knob.

4.) Remove shaft nut and lock washer securing oscillator assembly to front panel, and push oscillator assembly rearward, clear of panel, while lifting it around the cable and cable clamp just above it.

5.) Press oscillator assembly against shield next to 100 kHz Oscillator enough to clear chassis foot, and ease assembly back and clear. Use caution to prevent damaging oscillator assembly boards and wiring to filter block adjacent to MHz Oscillator assembly.

6.) Disconnection of wiring to the PC board is not normally necessary for making repairs, but if complete removal of oscillator assembly is required for other reasons, wiring should be unsoldered at this point. Reconnection is covered in installation procedures for this assembly.

7.) By removing the four screws and spacers fastening the PC board to the crystal switch assembly, permitting access to bottom of the PC board. Repairs to the PC board can be made without loosening the shaft coupling projecting from the rear of assembly. Loosening or removal of the shaft coupling will necessitate re-alignment of MHz Oscillator switch shaft with RF Amplifier and PA switch assemblies upon reassembly. This procedure is given in the installation instructions for the RF Amplifier.

8.) For removal and replacement of crystals in switch assembly, loosen or remove two nuts on rear of rear switch section, to permit sufficient separation of switch sections.

b. Assembly and Installation.

1.) Reassemble MHz Oscillator Assembly in reverse order of disassembly.

2.) Refer to figure 8.17 and reconnect wiring as follows:

a.) Solder center conductor of coaxial cable number 14 to E11, and shield lead to E13.

b.) Solder black ground lead to E12.

c.) Solder center conductor of coaxial cable number 6 to E9, and shield lead to E10.

d.) Solder black/white wire to E8.

3.) Replace oscillator assembly switch shaft through hole in front panel, positioning PC board wiring connections on side toward center of transceiver. Dress cable to MHz Oscillator and adjacent filter block to rear of oscillator assembly. Use caution to avoid damage to wiring to filter block next to oscillator assembly.

4.) Replace shaft retainer nut and lockwasher.

5.) Rotate switch shaft fully CCW, and reinstall control knob in position 9. Tighten both set screws.

6.) Install ground lug on shield between MHz and 100 kHz Oscillator assemblies.

7.) Install RF Amplifier assembly.

6.17.4.3 100 kHz and 10 kHz Oscillator Assemblies.

a. Removal and Disassembly (Same procedure for both 100 kHz and 10 kHz Oscillators).

1.) Remove two Allen screws in control knob and remove knob.

2.) Remove hardware fastening ground lugs (one on each shield) to shields on each side of 100 kHz Oscillator assembly; and remove ground lugs, leaving wiring attached.

3.) Remove shaft nut and lock washer securing switch assembly to front panel; and pull oscillator assembly forward, clear of panel.



4.) Disconnection of wiring is not normally necessary for repair of an oscillator PC board; but if complete removal of the assembly is desired for other reasons, wiring should be unsoldered at this point. Reconnection is covered in installation procedures.

5.) Remove four screws and spacers between PC board and phenolic board surrounding rear switch section to permit access to PC board for repairs.

6.) To permit removal and replacement of crystals, loosen or remove the two brass nuts on the rear of the rear switch section.

b. 100 kHz Oscillator Reassembly and Installation.

1.) Reassemble oscillator assembly in reverse order of disassembly.

2.) Refer to figure 8.19 and reconnect wiring as follows:

a.) Solder center conductor of coaxial cable number 13 to E23, and bare shield lead to E22. No connection to E21.

b.) Solder two white/brown wires to E20.

c.) Solder center conductor of remaining coaxial cable to E18, and bare shield lead to E19.

3.) Replace oscillator assembly switch shaft through hole in front panel, positioning PC board wiring connections on side toward center of transceiver. Dress cable to 100 kHz and MHz Oscillator assemblies into notch in shield between 100 kHz and 10 kHz Oscillator assemblies next to chassis.

4.) Replace shaft retainer nut and lockwasher.

5.) Rotate switch shaft fully CCW, and install control knob in number 9 position. Tighten set screws.

6.) Replace ground lugs removed in step (3) of 100 kHz removal and disassembly procedures.

7.) Install RF Amplifier assembly.

c. 10 kHz Oscillator Reassembly and Installation.

1.) Reassemble oscillator in reverse order of disassembly.

2.) Refer to figure 8.19, and reconnect wiring as follows:

a.) Solder center conductor of coaxial cable number 9 to E35 and bare shield lead to E22.

b.) Solder center conductor of coaxial cable number 8 to E30 and the bare shield lead to E31.

c.) Solder two black wires to E33.

d.) Solder two white/black/brown wires to E32.

3.) Replace oscillator assembly switch shaft through hole in front panel, positioning PC board wiring connections on side toward right of transceiver.

4.) Replace shaft retainer nut and lockwasher.

5.) Rotate switch shaft fully CCW, and install control knob in number 9 position. Tighten set screws.

6.) Replace ground lug removed from board during disassembly.

6.17.4.4 1 kHz Oscillator Assembly.

a. To remove the 1 kHz Oscillator assembly from the VFO tuning mechanism mounting it, proceed as follows:

1.) Set transceiver on right side.

2.) Remove nut retaining white nylon cable clamp on main cable harness to chassis at top of 1 kHz Oscillator, and push cable harness rearward to provide room for removal of oscillator assembly.

3.) Remove countersunk Phillips screw (lower right of crystal board) fastening oscillator assembly to round spacer attached to front panel.

4.) Remove countersunk Phillips screw (lower left of crystal board) fastening oscillator assembly to VFO microswitch mounting bracket.

5.) Loosen two slotted head screws in upper corners of oscillator PC board enough to free oscillator assembly to move rearward.



6.) For disassembly procedures for 1 kHz Oscillator assembly refer to those for 10 kHz Oscillator, which are similar.

b. Reassembly and Installation.

1.) Reassemble oscillator assembly in reverse order of disassembly.

2.) Refer to figure 8.23, and reconnect wiring as follows:

a.) Solder center conductor of coaxial cable number 10 to E42 and its bare shield lead to E43. Solder black outer shield lead to ground lug on relay chassis next to E45.

b.) Solder white/black/green wire to E44.

c.) Solder bare ground wire from E45 to ground lug in step (a) above.

d.) Solder center conductor of remaining coaxial cable to E47 and its bare shield lead to E46. Solder black outer shield lead to ground lug in step (a) above.

6.18 ALC.

Refer to figures 8.25 and 8.26 for ALC parts location and schematic diagrams.

6.18.1 ALC TEST PROCEDURE.

a. Remove the ALC board from the transceiver. Connect a dummy load to the antenna jack J4.

b. Set the transceiver for 2.500 MHz for CW transmission; and adjust PRESELECTOR, PA TUNE, and TRANSMIT AUDIO controls for an output of 100 watts. Advance the TRANSMIT AUDIO (only long enough to obtain reading) and note the power output where increasing the TRANSMIT AUDIO no longer increases the power output. If the power output does not exceed 100 watts, the ALC is not at fault. Turn TRANSMIT AUDIO fully CCW. Test the PA tubes and DC voltages of the PA. If more than 100 watts are available, reinstall the ALC Board and proceed.

c. Connect a DC VTVM to pin D of the ALC Board. VTVM indication should be 0.0V. Key transceiver and slowly increase to almost 100 watts. No change should occur in the pin D voltage. At about 100 watts, the increase in power should almost stop, and the DC voltage at pin D should increase from 0V to about 6V. If pin D voltage was not 0V,

the fault is in the Q3 circuit, the IF amplifier, or the ALC input network at the IF amplifier. If the voltage at pin D was 0 but did not change, the fault is in the Q1, Q2, or Q3 circuits or an open L7 (PA section).

6.18.2 ALC VOLTAGE MEASUREMENTS.

DC and AC voltage measurements for the ALC stages are given in table 6.15.

Table 6.15 — ALC Voltage Chart

STAGE	EMITTER	BASE	COLLECTOR	NOTES
DC VOLTAGES (a)				
Q1	11.7V	11.3V	60MV	Output voltage pin D 3.6V
Q2	120MV	60MV	11.6V	
Q3	11.7V	11.6V	4.4V	
AC (RMS) VOLTAGES (a)				
Q1	12 MV	240 MV	95 MV	
Q2	22 MV	95 MV	120 MV	
Q3	100 MV	120 MV	350 MV	

(a) Taken in CW transmit mode at 100 watts output test frequency 2.963 MHz. Voltages measured with HP-410B, TRANSMIT AUDIO in 2 o'clock position.

6.18.4 ALC ASSEMBLY REMOVAL AND INSTALLATION PROCEDURES.

6.18.4.1 Removal From Transceiver.

Remove two screws, one at each lower corner, securing PC board to chassis, and remove PC board.

6.18.4.2 Installation In Transceiver.

a. Plug five terminal connector on end of PC board into mating connector on chassis, properly aligning five mating terminals before engaging them.

b. Install two screws with washers one in each lower corner, securing PC board to chassis.

6.19 ACC.

Refer to figures 8.27 and 8.28 for parts location and schematic diagrams.



6.19.1 ACC TEST PROCEDURE.

- a. Connect dummy load to antenna jack J4.
- b. Tune Transceiver to Transmit CW on 2.555 MHz, and adjust PRESELECTOR, PA TUNE and TRANSMIT AUDIO for maximum power. Record this reading.
- c. Switch mode to AM, and key transmitter. The carrier level should read about one-fourth of the power transmitted in CW. Attempt to set the level by adjusting R6 on the ACC assembly. If the carrier level cannot be set and no power output is available, remove the ACC board and connect a 1,000 ohm resistor from pin E to pin D on J28. No output under this condition indicates the fault is in the 455 kHz Error Mixer Q7 circuit, or a signal or voltage to it. If the carrier is detectable on the power meter, but cannot be adjusted by R6, compare the ACC assembly voltages with those of table 6.16. These measurements should help locate the faulty component in Q1 or Q2 circuits.

6.19.2 ACC VOLTAGE MEASUREMENTS.

DC and AC voltage measurements for the ACC stages are given in table 6.16.

Table 6.16 – ACC Voltage Chart

STAGE	EMITTER	BASE	COLLECTOR	NOTES
DC VOLTAGES (a)				
Q1	.8 V	1.4 V	11.5 V	
Q2	.12 V	.8 V	2 V	
AC VOLTAGES				
(Insignificant)				

(a) Taken in AM transmit mode.

6.19.3 ACC CIRCUIT ALIGNMENT PROCEDURE.

- a. Connect dummy load to antenna connector and connect RF VTVM across dummy load.
- b. Tune transceiver for maximum output on CW, at 2.995 MHz. The output must be 70.7 volts minimum. Tune for CW transmit on 3.023 MHz. Set TRANSMIT AUDIO control for 70.7 volts and check panel meter for a 100 W, -10+50.

- c. Set TRANSMIT AUDIO control fully clockwise (but not in TUNE detent), note output voltage.

- d. Change FUNCTION switch to AM.

- e. Adjust R6 on ACC board for a level of one-half of the voltage noted under step c.

6.19.4 ACC ASSEMBLY REMOVAL AND INSTALLATION PROCEDURES.

6.19.4.1 Removal From Transceiver.

Remove two screws, one at each lower corner, securing PC board to chassis, and remove PC board.

6.19.4.2 Installation In Transceiver.

- a. Plug five terminal connector on end of PC board into mating connector on chassis, properly aligning five mating terminals before engaging them.

- b. Install two screws, one in each lower corner, securing PC board to chassis.

6.20 AUDIO AMPLIFIER.

Refer to figures 8.29 and 8.30 for parts location and schematic diagrams.

6.20.1 AUDIO AMPLIFIER TEST PROCEDURE.

To check this assembly, it is necessary to have an audio input, either by applying an RF signal to the antenna connector or an audio signal to the audio input terminal. It is important to maintain a load on the output of the assembly, either the speaker or a 3.2 ohm, 2 watt dummy load resistor. Set SPEAKER SWITCH to ON and tune to 2.555 MHz.

- a. Connect a RF signal generator, HP606A, to ANTENNA connector J4. Set for 0.5 uvolts at 2.555 MHz.

- b. Adjust RECEIVE AUDIO control for 56 MV at the base of Q1.

- c. Measure base of Q2 (25. MV) and collector of Q2 (600 MV).

6.20.2 AUDIO AMPLIFIER VOLTAGE MEASUREMENTS.

Significant voltages are given in table 6.17.

Table 6.17 – Audio Amplifier Voltage Chart

STAGE	EMITTER	BASE	COLLECTOR	NOTES
DC VOLTAGES				
Q1	7.8 V	8.4 V	13 V	
Q2	13.5 V	13.0 V	7.8 V	
Q3	7.2 V	7.8 V	13 V	
Q4	7.2 V	6.6 V	0.6 V	
Q5	13.8 V	13.0 V	7.2 V	
Q6	0.015 V	0.6 V	7.2 V	

6.20.3 AUDIO AMPLIFIER ALIGNMENT PROCEDURES.

No alignment required.

6.20.4 AUDIO AMPLIFIER ASSEMBLY REMOVAL AND INSTALLATION PROCEDURES.

6.20.4.1 Removal From Transceiver.

a. Unplug four terminal cable.

b. Remove PC board from chassis by sliding it up and out.

6.20.4.2 Installation In Transceiver.

a. Insert PC board into guides, and press down into position.

b. Connect four terminal cable connector to J26.

6.21 DC POWER MODULES.

Refer to figures 8.32 and 8.33 for schematic diagrams.

6.21.1 DC POWER MODULE TEST PROCEDURES.

Majority of DC Power Module problems result in blown fuse F1 in DC primary line. In these cases, replace fuse F1, and apply power to set. If fuse F1 blows again, the problem is probably a shorted transistor Q1 or Q2, or DC line filter capacitor C2 (and/or C1 in 26.0 VDC Power Module).

If DC primary fuse is not blown, but the set does not operate, the DC Power Module probably is not oscillating due to overloading in the transceiver or defective DC Power Module circuits. If possible, check operation of transceiver on AC to determine which is the case. If the DC Power Module appears to be defective, check its transistor collector to ground (T1 pin 7) waveforms against those in figure 6.24. The following procedure can be used to check the condition of transistors Q1 and Q2, and associated circuits, of the 13.5 VDC Power Module.

a. Set FUNCTION switch on transceiver to OFF position. Connect shorting jumper lead across R2 in Q1-Q2 emitter circuit. Connect an ammeter, set to 1 ampere range, from center post of XF1 fuseholder to positive side of capacitor C2. If an indication less than 200 MA is obtained, proceed to step b. If indication exceeds 200 MA, disconnect collector lead of transistor, Q1, at terminal 6 on T1 in transceiver. If reading drops to less than half,

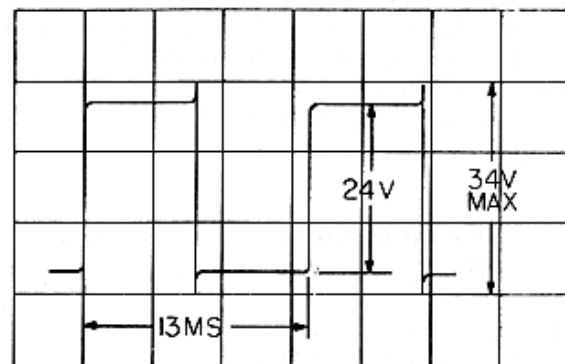

RF-303, 12 VDC
Q1 or Q2, Collector

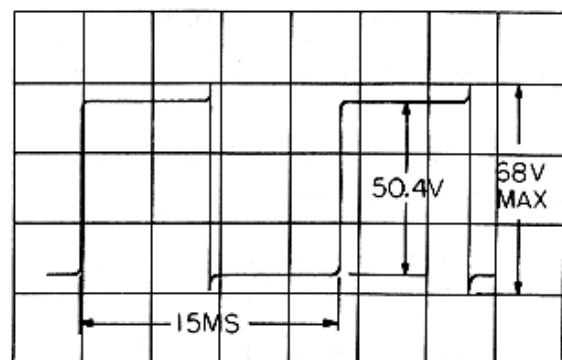

RF-304, 24 VDC
Q1 or Q2, Collector

Figure 6.24 – DC Power Module Waveforms



transistor Q1 has excessive leakage and should be replaced. If the reading is still over half, transistor Q2 (still connected) has excessive leakage and should be replaced.

b. Set ammeter to 10 ampere range and momentarily disconnect jumper across R2 long enough to observe new meter reading. Indication on ammeter should increase to at least two amperes. If meter reading is less than two amperes, the beta of one or both transistors is low. Disconnect base lead of transistor Q2 at terminal 3 of T1 in Power Module, and again momentarily disconnect jumper across R2 long enough to obtain new current reading on ammeter. If indication drops appreciably, the beta of transistor Q1 (still connected) is low and should be replaced. If indication on ammeter rises, the beta of transistor Q2 is low and should be replaced.

For RF-304 Power Module check transistors Q1 and Q2 for +26.0 VDC at collectors and +0.7 VDC at bases. Check for a 0.7 VDC drop across diode CR8. If one transistor is found defective replace both. If the transistors are replaced, adjust R7 until collector to ground waveform (figure 6.24) is symmetrical with zero axis.

6.21.2 POWER MODULE VOLTAGE MEASUREMENTS.

Collector to ground waveforms for transistors Q1 and Q2 in both Power Modules are given in figure 6.24.

6.21.3 POWER MODULE REMOVAL AND INSTALLATION PROCEDURE.

6.21.3.1 Removal From Transceiver.

a. RF-303 power module only - unsolder two black leads from J2, pins C and F only.

b. RF-304 power module only - unsolder two white leads from J2, pins C and F only.

c. Unsolder yellow wire from S1-A front, pin 3, on transceiver.

d. Unsolder blue wire from fuseholder XF-1 for RF-304, for RF-303 unsolder from vertical terminal strip.

e. Unsolder the red wire from fuseholder XF1 for RF-303, for RF-304 unsolder black wire from terminal strip.

f. Remove two screws on front lip of Power Module.

g. Remove two screws from top side of chassis behind the frequency standard, and remove Power Module.

6.21.3.2 Installation In Transceiver.

Refer to paragraph 2.3 for installation procedures.

6.22 FREQUENCY STANDARD ALIGNMENT PROCEDURES.

The frequency of the standard is adjusted at the time of manufacture, and should be readjusted only if there is good reason to believe that an improvement in accuracy is necessary and possible. In order to adjust the frequency, the transceiver should be connected to a dummy load with a "T" connector and set up for 10.000 MHz AM transmission. An accurate frequency counter should be connected to the "T" connector, through a 10 dB pad and the frequency of the AM carrier should be set for exactly 10.000 MHz. Remove the screw from the frequency standard cover for access to the adjustment screw. Turn the adjustment screw until the frequency counter reads 10.000,000 ± 5 cycles. Reinstall cover screw.

If it is necessary to replace either the frequency standard or Divider/Spectrum Generator Assembly, check the adjustment as described above.

If the standard is the optional high stability frequency standard, it will be packaged in a square can and have both FREQUENCY and OUTPUT amplitude adjustments. Turning the screw on the top of the standard opens the hole cover and allows a small type of tuning tool to be inserted to adjust the frequency or amplitude. The frequency is adjusted in the same manner as the regular standard. The output amplitude is adjusted in the following manner:

a. Set up transceiver to receive on 2.444 MHz in any mode.

b. At Divider/Spectrum Generator Assembly, connect oscilloscope to junction of R70 and C45.



c. Rotate OUTPUT adjustment on frequency standard until oscilloscope displays waveform as shown in figure 6.7, page 6-17.

6.23 RECEIVER PROTECTOR.

Refer to figures 8.34 and 8.35 for parts locations and schematic diagram.

6.23.1 RECEIVER PROTECTOR TEST PROCEDURES.

a. Perform the performance test outlined in paragraph 5.8.1.

b. If the test fails make voltage checks using the information presented in table 6.18.

c. Replace faulty component and repeat the procedures of paragraph 5.8.1.

Table 6.18 – Receiver Protector Voltage Chart

STAGE	EMITTER	BASE	COLLECTOR	NOTES
Q1	0.07 V 0.2 V	0 V 0.66 V	12 V 0.3 V	(a) (b)

(a) With no signal at E103.

(b) With 6 volts, 2.5 MHz, at E103.



SECTION 7 PARTS LIST

REF DESIG	DESCRIPTION	RF P/N
MAIN FRAME ASSEMBLY		
B1	FAN, 115 VAC	B-0013
C1	Capacitor, oil-paper, 12 uF, 1K VDCW	C-2251
C3	Capacitor, electrolytic, 200 uF, 500 VDCW	C-4053
C4	Capacitor, ceramic, 250 pF, 1K VDCW	C-0636
C5, C6	Capacitor, electrolytic, 20 uF, 100 VDCW	C-1123
C7	Same as C4	C-0636
C14	Capacitor, ceramic, .1 uF, 25 VDCW	C-2210
C15, C17	Capacitor, ceramic, .01 uF, 1000 VDCW	C-5000
C16/C18	Capacitor, ceramic, .01 uF, 500 VDCW	C-0003
C19	Same as C15	C-5000
C20	Capacitor, ceramic, 68 pF, 1K VDCW	C-0612
C21	Capacitor, dipped-mica, 18 pF, 1K VDCW	C-4744
C22	Capacitor, ceramic, .1 uF, 75 VDCW	C-0063
C23	Capacitor, Ceramic, .01 uF, 1 K VDCW	C-0008
C24	Capacitor, ceramic, 39 pF, 1K VDCW	C-0638
C25	Capacitor, ceramic, 180 pF, 1K VDCW	C-0615
C26	Same as C22	C-0063
C27	Capacitor, ceramic, 80 pF, 1K VDCW	C-0609
C28, C29	Capacitor, ceramic, 120 pf, 1K VDCW	C-0613
C30	Capacitor, ceramic, 200 pF, 1K VDCW	C-0630
C31	Capacitor, ceramic, 270 pF, 1K VDCW	C-0616
C32, C33	Capacitor, ceramic, 560 pF, 1K VDCW	C-0633
C34	Capacitor, ceramic, 680 pF, 1K VDCW	C-0634
C35	Capacitor, ceramic, 1000 pF, 1K VDCW	C-0621
C36, C37	Same as C34	C-0634
C38	Capacitor, mylar, 1 uF, 400 VDCW	C-0860
C39	Capacitor, ceramic, .01 uF, 75 VDCW	C-4300
C40	Capacitor, tantalum 15 uF, 20 VDCW	C-5832
C41	Capacitor, variable, 8-50 pF	C-0404
	<i>Capacitor, Dürz; .01 uF/50 VDC</i>	<i>C-4952</i>
ENTER CHANGE DATA		
B1	<i>kuglelijer ADR WX 3/16 ZZ</i>	

REF DESIG	DESCRIPTION	RF P/N
C42,C43	Capacitor, dipped-mica 110 pF, 500 VDCW, 5%	C-0127
C44,C45	Same as C41	C-0404
C46,C47	Same as C42	C-0127
C48	Same as C41	C-0404
C49/C52	Same as C14	C-2210
C53/C55	Capacitor, ceramic, .01 75 VDCW	C-0065
C57	Same as C14	C-2210
C60/C62	Capacitor, Ceramic, 1 uF, 75 VDCW	C-0063
C63/C70	Capacitor, ceramic, 1500 pF, 500 VDCW	C-2651
C75	Same as C53	C-0065
C81	Capacitor, ceramic, .005 uF, 500 VDCW	C-0002
C82	Same as C53	C-0065
C83	Same as C16	C-0003
C84	Capacitor, electrolytic, 5600 uF, 20 VDCW	C-4959
C85	Same as C84	
C86	Capacitor, electrolytic, 5 uF, 450 VDCW	C-4052
CR1/CR11	Diode, silicon, type 1N3256	CR-0045
CR 12	Diode, zener, type UZ8709	CR-0352
CR13 /CR19	Diode, silicon, 1N4001	CR-0043
CR20/CR21	Diode, germanium, type 1N270	CR-0047
CR22	Diode, silicon, type 1N4454	CR-0705
CR23	Diode, silicon, type 1N816	CR-0050
CR24	Same as CR20	CR-0047
DS1	Lamp, pilot, 6 volts	DS-0026
F1	Fuse, type AGC: 25 AMP for 13.5 VDC operation 15 AMP for 26.0 VDC operation	F-0019 F-0018
F2	Fuse, type AGC: 4 AMP for 115 VAC operation 3 AMP for 230 VAC operation	F-0014 F-0013
FL1/FL3	Parasitic suppressor choke assembly	162-0187
FL4	Choke assembly	162-0384
FL5	Filter, mechanical, 455 kHz lower-sideband	FL-0001
FL6	Filter, mechanical, 455 kHz upper-sideband	FL-0004
J1	Connector, 7 pin	J-0402
J2	Connector, 7 pin	J-0555
J3	Connector, 12 pin	J-0401
J4	Connector, coax, type UHF	J-0200
J5	Connector, 7 pin	J-0400
J18	Connector, 5 pin	162-0199
J23	Connector, 23 pin	J-0340
J24	Connector, 5 pin	162-0149
J26	Connector, 4 pin	162-0173
J28	Connector, 5 pin	162-0148
J30	Connector, feedthru	J-0030
J37	Socket, relay	J-0801
J38	Connector, fan	J-0350
ENTER CHANGE DATA		

CR-0047



REF DESIG	DESCRIPTION	RF P/N
J39	Same as J37	J-0801
J40	Connector, 3 pin	162-0145
J41	Same as J37	J-0801
J100	Phone jack	J-0102
K1	Relay, 115 VAC	K-0042
K2/K4	Relay, 12 VDC	K-0041
L3	Choke, RF, 240 uH	L-0052
L5	Choke, RF, 150 uH	162-0154
L6	Coil, roller	162-0177
L7	Choke, RF, 1 MH	L-0031
L8, L9	Choke, RF, 1.5 MH	L-0031
LS1	Speaker	162-0045
M1	Meter, panel	162-0184
P7, P8	Connector, coax, miniature	P-0032
P12, P13	Same as P7	P-0032
P16, P17	Same as P7	P-0032
P20	Connector, multi-pin	162-0375
P24	Same as P7	P-0032
P31	Connector, multi-pin	162-0373
P33/P35	Same as P7	P-0032
P38	Connector, fan	P-0350
P42/P43	Same as P7	P-0032
Q3	Transistor, type 2N3642	Q-0320
R1	Resistor, composition, 470K, 2W, 10%	R-0356
R2	Resistor, composition, 4.7K, 2W, 10%	R-0332
R3	Resistor, composition, 680 ohms, 1/2W, 10%	R-0122
R4	Potentiometer, 5K, 2W	R-3156
R5	Resistor, composition, 82K, 2W, 10%	R-0347
R6	Resistor, composition, 3.9K, 1/2W, 10%	R-0131
R9	Resistor, composition, 270 ohms, 1W, 10%	R-0217
R10	Potentiometer, 500 ohms, 2W	R-3171
R11	Resistor, composition, 10K, 1/2W, 10%	R-0136
R12/R14	Resistor, Composition, 100 ohms, 1/2W, 10%	R-0112
R15	Resistor, film, 50 ohms, 7W, ±10%	R-0955
R16	Resistor, composition, 100K, 2W, 10%	R-0348
R18	Resistor, composition, 2.2K, 1/4W, 10%	R-0028
R19	Potentiometer, 1K, 2W with DPST switch S101	R-3174
R20	Potentiometer, 1K, 2W	R-3170
R22	Resistor, composition, 18K, 1/4W, 10%	R-0039
R23	Same as R18	R-0028
R24	Resistor, composition, 1.5K, 1/4W, 10%	R-0026
R25	Resistor, composition, 470 ohms, 1/2W, 10%	R-0120
R26	Resistor, composition, 2.7K, 1/4W, 10%	R-0029
R27	Resistor, composition, 15K, 1W, 5%	R-4000
R28	Resistor, composition, 750 ohms, 1/2W, 5%	R-4001
R29	Resistor, composition, 8.2K, 1/2W, 10%	R-0135
R30	Resistor, composition, 33K, 1/2W, 10%	R-0142
ENTER CHANGE DATA		

REF DESIG	DESCRIPTION	RF P/N
R31	Resistor, composition, 2.7K, 1/2W, 5%	R-1459
R32	Resistor, composition, 2.2K, 1/4W, 5%	R-1257
R33	Resistor, composition, 22K, 1/4W, 10%	R-0040
R40/42	Resistor, composition, 39 ohms, 2W, 10%	R-0307
R50	Resistor, composition, 47K, 1/2W, 10%	R-0144
R55	Resistor, composition, 22 ohms, 1W, 10%	R-0204
R56	Resistor, composition, 15K, 1/2W, 10%	R-0138
R57	Resistor, composition, 2.2K, 1/2W, 10%	R-0128
R58	Resistor, wirewound, 100 ohms, 5W, 10%	R-3814
R59	Resistor, Wirewound; 1 ohm ±5%, 3W	R-3221
S1	Switch, rotary, wafer	162-0152
S2	Switch, rotary, wafer	162-0191
S3	Switch, toggle, SPST	S-0203
S4	Switch, toggle, DPDT	S-0201
S5	Micro switch	S-0080
S6	Switch, rotary, wafer	162-0151
S7	Switch, push-button	S-0081
S100	Same as S3	S-0203
S101	Part of R19	R-3174
T1	Transformer, power	162-0175
V1/V3	Tube, electron, type 6146B	V-0105
XF1	Fuseholder, AC	X-0081
XF2	Fuseholder, DC	X-0081
	Air Filter	MP-1187
	Line cord assembly, 115 VAC	162-0021
	Line cord assembly, 230 VAC	162-0022
	Microphone and cable connector	162-0020
	Connector, microphone	P-0400
	Plug, power (AC)	P-0402
	Plug, power (DC)	P-0555
	TRANSISTOR FILTER BOARD	162-0420
C1	Capacitor, electrolytic, 220 uF, 20 VDCW	C-4166
C2	Capacitor, electrolytic, 580 uF, 15 VDCW	C-4162
F1	Fuse, 3AG, 1.5A	F-0011
Q1	Transistor type MJ1000	Q-0133
R1	Resistor, composition, 330 ohms, 1/2W, 10%	R-0118
R2	Resistor, composition, 330 ohms, 1/2W, 10%	R-0118
-02-	RF AMPLIFIER ASSEMBLY	162-0200
	RF Amplifier PC Board Assembly	162-0260
	RF Band Switch Assembly, Section A	162-0206
	RF Band Switch Assembly, Section B	162, 0207
	RF Band Switch Assembly, Section C	162-0208
ENTER CHANGE DATA		



REF DESIG	DESCRIPTION	RF P/N
	RF Band Switch Assembly, Section D	162-0209
C1	Capacitor, variable, 9-35 pF	C-2302
C2	Capacitor, dipped-mica, 82 pF 500 VDCW, 2%	C-2477
C3	Capacitor, dipped-mica, 470 pF, 500 VDCW, 2%	C-2496
C4	Same as C1	C-2302
C5	Capacitor, dipped-mica, 5 pF, 500 VDCW, 5%	C-0103
C6	Same as C1	C-2302
C7	Capacitor, dipped-mica, 1100 pF, 500 VDCW, 2%	C-3400
C8	Same as C5	C-0103
C9	Capacitor, dipped-mica, 10 pF, 500 VDCW, 5%	C-0104
C10	Capacitor, dipped-mica, 15 pF, 500 VDCW, 5%	C-0106
C11	Capacitor, dipped-mica, 27 pF, 500 VDCW, 5%	C-0111
C12	Same as C5	C-0103
C13	Same as C1	C-2302
C14	Same as C2	C-2477
C15	Same as C3	C-2496
C16	Same as C1	C-2302
C17	Capacitor, dipped-mica, 100 pF, 500 VDCW, 2%	C-2479
C18	Same as C1	C-2302
C19	Same as C7	C-3400
C20	Same as C1	C-2302
C21	Same as C2	C-2477
C22	Same as C3	C-2496
C23	Same as C1	C-2302
C24	Capacitor, dipped-mica, 36 pF, 500 VDCW, 2%	C-2497
C25	Same as C1	C-2302
C26	Same as C7	C-3400
C27	Same as C5	C-0103
C28	Same as C1	C-2302
C29	Same as C2	C-2477
C30	Same as C3	C-2496
C31	Same as C1	C-2302
C32	Capacitor, dipped-mica, 43 pF, 500 VDCW, 2%	C-2496
C33	Same as C1	C-2302
C34	Same as C7	C-3400
C35	Same as C5	C-0103
C36/C38, C40	Capacitor, variable, 11,110 pF	162-0271
C41	Capacitor, dipped-mica, 2400 pF	162-0270
C42	Capacitor, ceramic, .001 uF, 500 VDCW	C-0001
C43,C44	Capacitor, ceramic, .01 uF, 150 VDCW	C-0065
C45	Capacitor, ceramic, .01 uF, 500 VDCW	C-0003
C46	Same as C43	C-0065
C47	Same as C41	C-0152
C48	Same as C45	C-0003
C49	Same as C42	C-0001
C50	Capacitor, dipped-mica, 82 pF, 500 VDCW, 5%	C-0124
C51	Same as C36	162-0271
C52	Capacitor, feedthru, 2400 pF	162-0270
C53	Capacitor, dipped-mica, 43 pF, 500 VDCW, 5%	C-0116
C54, C56	Same as C45	C-0003
ENTER CHANGE DATA		

REF DESIG	DESCRIPTION	RF P/N
C57	Same as C43	C-0065
C58	Capacitor, ceramic, .1 uF, 25 VDCW	C-2210
C60	Capacitor, dipped-mica, 82 pF, 500 VDCW, 5%	C-0124
C61	Capacitor, dipped-mica, 1000 pF, 500 VDCW, 5%	C-0152
C62	Same as C58	C-2210
C65	Capacitor, mica, 39 pF 500 VDCW, 5%	C-0115
CR1	Diode, silicon, type 1N270	CR-0047
CR2	Diode, zener, type 1N753A	CR-0046
CR3	Same as CR1	CR-0047
CR4	Diode, silicon, type 1N4001	CR-0043
K1	Relay, 4PDT, 12 VDC	K-0041
L1	Inductor	162-0276
L2, L3	Inductor	162-0278
L4	Same as L1	162-0276
L5	Choke, RF, 1 MH, 185 MA	L-0050
Q1	Transistor, type 2N3644	Q-0315
R1	Resistor, composition, 1K, 1/4W, 10%	R-0024
R2	Resistor, composition, 47 ohms, 1/4W, 10%	R-0008
R3	Resistor, composition, 220K, 1/2W, 10%	R-0152
R4	Resistor, composition, 10K, 1/2W, 10%	R-0136
R5	Resistor, composition, 2.2K, 1/2W, 10%	R-0128
R6	Resistor, composition, 220 ohms, 1/2W, 10%	R-0116
R7	Resistor, composition, 4.3K, 1/2W, 5%	R-1464
R8	Resistor, composition, 33K, 1/2W, 10%	R-0142
R9	Resistor, composition, 68K, 1/2W, 10%	R-0146
R10	Resistor, composition, 220 ohms, 1/2W, 5%	R-1433
R11	Resistor, composition, 12K, 5W, 5%	R-0607
R12	Resistor, composition, 3.3K, 2W, 5%	R-3218
R13	Resistor, composition, 1K, 1/2W, 10%	R-0124
R14	Resistor, composition, 100K, 1/2W, 10%	R-0148
R15	Resistor, composition, 68 ohms, 1/2W, 5%	R-1421
R17	Resistor, composition, 1.8K, 1/2W, 10%	R-0127
R18	Resistor, composition, 470 ohms, 2W, 5%	R-3217
R19	Resistor, composition, 8.2K, 1/2W, 10%	R-0135
R20	Resistor, composition, 8.2K, 1/2W, 5%	R-1471
R21	Same as R19	R-0135
R22	Same as R20	R-1471
R23	Same as R19	R-0135
R24	Same as R20	R-1471
R25	Same as R19	R-0135
R26	Same as R20	R-1471
R29	Resistor, composition, 5.6K, 1/2W, 10%	R-0133
R31	Potentiometer, 500 ohms, 1W, 10%	R-3100
S1	Switch, section, rotary	162-0283
ENTER CHANGE DATA		



REF DESIG	DESCRIPTION	RF P/N
V1	Tube, electron 6DC6	V-0000
V2	Tube, electron, 12BY7A	V-0018
Y1	Crystal, 8.247 MHz	162-0196
Y2	Crystal, 9.247 MHz	162-0193
Y3	Crystal, 12.494 MHz	162-0194
Y4	Crystal, 12.741 MHz	162-0195
Z1	Ferrite Iron Bead	E-0652
-03-	DIVIDER AND SPECTRUM GENERATOR ASSEMBLY	162-0300
C2	Capacitor, dipped-mica, 75 pF, 500 VDCW, 5%	C-0123
C3	Capacitor, ceramic, .1 uF, 25 VDCW	C-2210
C4, C5	Same as C2	C-0123
C6	Capacitor, tantalum, 15 uF, 20 VDCW, 20%	162-0273
C7	Capacitor, dipped-mica, 5 pF, 500 VDCW, 5%	C-0103
C8	Capacitor, dipped-mica, 120 pF, 500 VDCW, 5%	C-0128
C9	Capacitor, polystyrene, .0022 uF, 100 VDCW	C-2700
C10	Same as C2	C-0123
C11	Same as C3	C-2210
C12, C13	Same as C2	C-0123
C14	Same as C6	162-0273
C15	Same as C7	C-0103
C16	Capacitor, dipped-mica, 20 pF, 500 VDCW, 5%	C-0108
C17	Capacitor, polystyrene, .022 uF, 100 VDCW	C-2701 162-0273
C18	Same as C2	C-0123
C19	Same as C3	C-2210
C20, C21	Same as C2	C-0123
C22	Same as C6	162-0273
C23	Capacitor, dipped-mica, 10 pF, 500 VDCW, 5%	C-0104
C24	Same as C16	C-0108
C25	Capacitor, polystyrene, .33 uF, 100 VDCW	C-2702
C26	Capacitor, dipped-mica, 68 pF, 500 VDCW, 5%	C-0122
C27	Capacitor, ceramic, .05 uF, 30 VDCW	C-0060
C28	Capacitor, ceramic, .02 uF, 30 VDCW	C-0066
C29	Capacitor, dipped-mica, 56 pF, 500 VDCW, 5%	C-0120
C30	Capacitor, dipped-mica, 330 pF, 500 VDCW, 5%	C-0139
C31	Capacitor, film, .22 uF, 100 VDCW, 20%	C-2350
C32	Same as C27	C-0060
C33	Capacitor, dipped-mica, 820 pF, 300 VDCW, 2%	C-2503
C34	Capacitor, ceramic, 68 pF, N-220, 150 VDCW	C-2801
C35	Same as C27	C-0060
C36	Capacitor, ceramic, 330 pF, 2%, N-080, 150 VDCW	C-2804
C37	Capacitor, dipped-mica, 100 pF, 500 VDCW, 5%	C-0126
C38	Capacitor, ceramic, 110 pF, N-080	C-2661
ENTER CHANGE DATA		

REF DESIG	DESCRIPTION	RF P/N
C39	Same as C3	C-2210
C41	Same as C33	C-2503
C42	Same as C3	C-2210
C43	Capacitor, dipped-mica, 220 pF, 500 VDCW, 5%	C-0134
C44	Capacitor, dipped-mica, 82 pF, 500 VDCW, 5%	C-0124
C45	Same as C3	C-2210
C46	Same as C3	C-2210
C47	Same as C33	C-2503
C48	Capacitor, dipped-mica, 3000 pF, 500 VDCW, 5%	C-0164
C49	Capacitor, ceramic, .1 uF, 25 VDCW	C-2210
CR1	Diode, zener, type 1N4739A	CR-0351
CR2	Diode, silicon, type 1N649	CR-0050
CR3/CR11	Diode, germanium, type 1N270	CR-0047
CR12/CR15	Same as CR2	CR-0050
CR16	Same as CR3	CR-0047
J43	Connector, receptacle, coax	J-0031
L1/L4	Inductor, 1 MH	L-0050
L5	Inductor, .47 uH	L-0028
L6	Inductor, .22 uH	L-0029
L7	Inductor, .15 uH	L-0074
P14	Coax cable assembly	162-0312
P15	Coax cable assembly	162-0313
P36	Coax cable assembly	162-0310
P46	Coax cable assembly	162-0311
Q1/Q3	Transistor, type 2N3638A	Q-0319
Q4	Transistor, type 2N3904	Q-0361
Q5	Transistor, type 2N4916	Q-0360
Q6/Q7	Same as Q1	Q-0319
Q8	Same as Q4	Q-0361
Q9/Q11	Same as Q1	Q-0319
Q12	Same as Q4	Q-0361
Q13	Same as Q1	Q-0319
Q14	Same as Q4	Q-0361
Q15	Same as Q1	Q-0319
Q16/Q19	Transistor, type 2N3644	Q-0315
Q20	Same as Q4	Q-0361
R1	Resistor, composition, 82 ohms, 1W, 5%	R-1623
R2	Resistor, composition, 4.7K, 1/4W, 10%	R-0032
R3	Resistor, composition, 10K, 1/4W, 10%	R-0036
R4	Resistor, composition, 6.8K, 1/4W, 10%	R-0034
R5	Resistor, composition, 1.8K, 1/4W, 10%	R-0027
R6, R7	Same as R3	R-0036
R8	Resistor, composition, 330 ohms, 1/4W, 10%	R-0018
R9	Same as R4	R-0034
R10	Same as R5	R-0027
R11	Potentiometer, 10K, 1/2W, 10%	R-3104
R12	Same as R3	R-0036
R13	Resistor, composition, 180 ohms, 1/4W, 10%	R-0015
R14	Resistor, composition, 220 ohms, 1/4W, 10%	R-0016
R15	Same as R3	R-0036
R16	Resistor, composition, 470 ohms, 1/4W, 10%	R-0020
ENTER CHANGE DATA		



REF DESIG	DESCRIPTION	RF P/N
R17	Same as R3	R-0036
R18	Same as R4	R-0034
R19	Same as R5	R-0027
R20, R21	Same as R3	R-0036
R22	Same as R4	R-0034
R23	Same as R5	R-0027
R24	Same as R11	R-3104
R25	Same as R3	R-0036
R26	Resistor, composition, 560 ohms, 1/4W, 10%	R-0021
R27	Same as R14	R-0016
R28	Same as R3	R-0036
R29	Same as R5	R-0027
R30	Same as R3	R-0036
R31	Same as R4	R-0034
R32	Same as R3	R-0036
R33	Same as R5	R-0027
R34	Same as R3	R-0036
R35	Same as R5	R-0027
R36	Same as R14	R-0016
R37	Same as R4	R-0034
R38	Same as R11	R-3104
R39	Resistor, composition, 2.7K, 1/4W, 10%	R-0029
R40	Same as R3	R-0036
R41	Resistor, composition, 1K, 1/4W, 10%	R-0024
R42	Same as R26	R-0021
R43	Same as R3	R-0036
R44	Resistor, composition, 100 ohms, 1/4W, 10%	R-0012
R45	Resistor, composition, 82 ohms, 1/4W, 10%	R-0011
R46	Same as R2	R-0032
R47	Resistor, composition, 5.6K, 1/4W, 10%	R-0033
R48	Resistor, composition, 1.2K, 1/4W, 10%	R-0025
R49	Resistor, composition, 8.2K, 1/4W, 10%	R-0035
R50	Same as R5	R-0027
R51	Same as R3	R-0036
R53	Same as R48	R-0030
R54	Resistor, composition, 680 ohms, 1/4W, 10%	R-0022
R55, R56	Resistor, composition, 15K, 1/4W, 10%	R-0038
R57	Resistor, composition, 1.2K, 1/4W, 10%	R-0025
R58	Same as R48	R-0030
R59, R60	Resistor, composition, 22 ohms, 1/4W, 10%	R-0004
R61	Resistor, composition, 39 ohms, 1/4W, 10%	R-0007
R62	Resistor, composition, 4.7 ohms, 1/4W, 10%	R-0077
R63, R64	Resistor, composition, 100 ohms, 1/4W, 10%	R-0012
R65	Resistor, composition, 10 ohms, 1/4W, 10%	R-0000
R66	Potentiometer, 500 ohms, 1W, 10%	R-3361
R67	Resistor, composition, 5.6 ohms, 1/4W, 5%	R-0858
R68	Same as R47	R-0033
R69	Same as R47	R-0033
R70	Resistor, composition, 1.5K, 1/4W, 10%	R-0026
ENTER CHANGE DATA		

REF DESIG	DESCRIPTION	RF P/N
R71	Resistor, composition, 2.2K, 1/4W, 10%	R-0028
R72	Same as R41	R-0024
T2	Transformer	162-0156
T3, T4	Transformer	162-0157
-04-	11.6 MHz ERROR MIXER ASSEMBLY	162-0400
C1, C2	Capacitor, ceramic, .1 uF, 25 VDCW	C-2210
C3	Capacitor, ceramic, .005, 100 VDCW	C-2220
C4	Capacitor, dipped-mica, 200 pF, 500 VDCW, 5%	C-0133
C5	Capacitor, variable, 7.25 pF	C-2304
C6	Same as C1	C-2210
C7	Capacitor, dipped-mica, 68 pF, 500 VDCW, 5%	C-0122
C8	Same as C5	C-2304
C9	Capacitor, dipped-mica, 110 pF, 500 VDCW, 5%	C-0127
C10/C15	Same as C1	C-2210
C16	Same as C5	C-2304
C17	Capacitor, tantalum, 15 uF, 20 VDCW	162-0273
C18, C19	Same as C1	C-2210
C20	Capacitor, variable, 2.5-11 pF	C-2303
C21	Same as C1	C-2210
C22	Same as C5	C-2304
C23	Capacitor, dipped-mica, 100 pF, 500 VDCW, 5%	C-0127
C24	Same as C1	C-2210
C25	Capacitor, dipped-mica, 43 pF, 500 VDCW, 2%	C-2469
C26/C30	Same as C1	C-2210
C31	Same as C5	C-2304
C32	Capacitor, dipped-mica, 100 pF, 500 VDCW, 5%	C-0126
C3	Same as C5	C-2304
C34	Same as C20	C-2303
C35	Capacitor, dipped-mica, 130 pF, 500 VDCW, 5%	C-0129
C36	Same as C5	C-2304
C37/C45	Same as C1	C-2210
C46, C47	Capacitor, dipped-mica, 20 pF, 500 VDCW, 5%	C-0108
CR1/CR4	Diode, silicon, type 1N4454	CR-0705
FL1	Filter, 7.7 MHz	FL-0102
FL2	Filter, 2.5 MHz	FL-0100
FL3	Filter, 11.6 MHz	FL-0105
FL4	Filter, 21.0 MHz	FL-0101
FL5	Filter, 14.2 MHz	FL-0107
J33/J36	Connector, receptacle, coax	J-0031
J42	Same as J33	J-0031
J46	Coax cable assembly	162-0315
L1/L7	Inductor, 240 uH	L-0052
L8	Inductor, .15 uH	L-0074
P9	Coax cable assembly	162-0314
Q1/Q4	Transistor, type 2N4916	Q-0360
Q5	Transistor, type 2N3283	Q-0380
Q6/Q9	Same as Q1/Q4	Q-0360
R1	Resistor, composition, 10K, 1/4W, 10%	R-0036
ENTER CHANGE DATA		



REF DESIG	DESCRIPTION	RF P/N
R2	Resistor, composition, 15K, 1/4W, 10%	R-0038
R3	Resistor, composition, 1.2K, 1/4W, 10%	R-0025
R4	Resistor, composition, 100 ohms, 1/4W, 10%	R-0012
R5	Resistor, composition, 33 ohms, 1/2W, 10%	R-0006
R6	Resistor, composition, 3.3K, 1/4W, 10%	R-0030
R7	Same as R2	R-0038
R8	Same as R2	R-0038
R9	Resistor, composition, 15 ohms, 1/4W, 10%	R-0002
R10	Same as R1	R-0036
R11	Resistor, composition, 1K, 1/4W, 10%	R-0024
R12	Same as R6	R-0030
R13	Same as R2	R-0038
R14, R15	Resistor, composition, 2.2K, 1/4W, 10%	R-0028
R16	Same as R6	R-0030
R17	Same as R2	R-0038
R18	Same as R3	R-0025
R19	Resistor, composition, 47 ohms, 1/4W, 10%	R-0008
R20	Same as R1	R-0036
R21	Same as R14, R15	R-0028
R22	Same as R6	R-0030
R23	Same as R2	R-0038
R24	Same as R3	R-0025
R25	Same as R1	R-0036
R26	Same as R2	R-0038
R27	Same as R3	R-0025
R28	Same as R4	R-0012
R29	Same as R5	R-0006
R30	Same as R6	R-0030
R31	Same as R2	R-0038
R32	Same as R3	R-0025
R33	Resistor, composition, 22K, 1/4W, 10%	R-0040
R34	Resistor, composition, 220 ohms, 1/4W, 10%	R-0016
R35	Same as R6	R-0030
R36	Same as R2	R-0038
R37	Same as R6	R-0030
R38	Same as R2	R-0038
R39	Resistor, composition, 1.5K, 1/4W, 10%	R-0026
R40	Same as R1	R-0036
R41	Resistor, composition, 560 ohms, 1/4W, 10%	R-0021
R42	Same as R2	R-0038
R43	Same as R4	R-0012
T1, T2	Transformer	162-0159
-05-	455 kHz ERROR MIXER ASSEMBLY	162-0500
C1	Capacitor, ceramic, .1 uF, 25 VDCW	C-2210
C2	Capacitor, .0047 uF, 100 VDCW	C-2108
C3	Capacitor, variable, 7-25 pF	C-2304
C4	Same as C1	C-2210
C5	Capacitor, dipped-mica, 120 pF, 500 VDCW, 5%	C-0128
ENTER CHANGE DATA		

REF DESIG	DESCRIPTION	RF P/N
C7	Capacitor, dipped-mica, 620 pF, 300 VDCW, 5%	C-2500
C8, C9	Same as C1	C-2210
C10	Capacitor, mylar, .015 uF, VDCW	C-2114
C11	Same as C3	C-2304
C12, C13	Same as C1	C-2210
C14	Same as C5	C-0128
C15	Capacitor, variable, 3-30 pF	C-4014
C16	Capacitor, ceramic, .05 uF, 30 VDCW	C-0060
C19, C20	Same as C1	C-2210
C21	Capacitor, dipped-mica, 820 pF, 300 VDCW, 2%	C-2503
C22	Capacitor, dipped-mica, 270 pF, 500 VDCW, 5%	C-0137
C23, C24	Same as C1	C-2210
C26	Same as C1	C-2210
C27, C28	Same as C1	C-2210
C29	Capacitor, dipped-mica, 100 pF, 5%, 500 VDCW	C-0126
C30	Capacitor, dipped-mica, 1200 pF, 500 VDCW, 5%	C-3401
C31	Capacitor, dipped-mica, 240 pF, 500 VDCW, 5%	C-2488
C34	Same as C1	C-2210
C35	Capacitor, tantalum, 15 uF, 20 VDCW	162-0273
C36, C37	Same as C1	C-2210
C38	Capacitor, ceramic; 0.005 uF, 500 VDCW	C-0002
CR1/CR3	Diode, germanium, type 1N270	CR-0047
CR4/CR7	Diode, silicon, type 1N4454	CR-0705
CR8	Same as CR1	CR-0047
CR9	Diode, zener, type 1N4739A	CR-0351
FL1	Filter, 646.5 kHz	FL-0104
FL2	Filter, 1.1015 MHz	FL-0103
FL3	Filter, 455 kHz	162-0521
FL3-C1	Capacitor, dipped mica, 390 pF, 500 VDCW, 5%	C-2494
FL3-C2	Capacitor, dipped mica, 10 pF, 500 VDCW, 5%	C-0104
FL3-C3	Capacitor, dipped mica, 620 pF, 300 VDCW, 5%	C-2500
FL3-C4	Capacitor, dipped mica, 20 pF, 500 VDCW, 5%	C-0108
FL3-C5	Capacitor, dipped mica, 820 pF, 300 VDCW, 2%	C-2503
FL3-L1	Inductor	162-0155
FL3-L2	Inductor	162-0155
FL3-T1	Transformer	162-0162
J12/J17	Connector, receptacle, coax	J-0031
L2	Inductor, 1 MH	L-0050
Q1/Q5	Transistor, type 2N4916	Q-0360
Q6	Transistor, type 2N2084	Q-0105
Q7	Transistor, type 2N1224	Q-0108
R1	Resistor, composition, 3.3K, 1/2W, 10%	R-0030
R2	Resistor, composition, 10K, 1/4W, 10%	R-0036
R3	Resistor, composition, 1.5K, 1/4W, 10%	R-0026
R4	Same as R2	R-0036
R5	Resistor, composition, 680 ohms, 1/4W, 10%	R-0022
R6	Same as R1	R-0030
R7	Same as R2	R-0036
R8	Same as R3	R-0026
ENTER CHANGE DATA		



REF DESIG	DESCRIPTION	RF P/N
R9	Resistor, composition, 5.6, 1/4W, 10%	R-0033
R10	Same as R1	R-0030
R11	Same as R2	R-0036
R12	Same as R3	R-0026
R14	Same as R2	R-0036
R15	Resistor, composition, 820 ohms, 1/4W, 10%	R-0023
R16	Resistor, Composition, 3.3K, 1/2W, 10%	R-0030
R17	Same as R2	R-0036
R18	Same as R3	R-0026
R19	Resistor, composition, 6.8K, 1/4W, 10%	R-0034
R20	Same as R1	R-0030
R21	Same as R5	R-0022
R22	Same as R2	R-0036
R23	Resistor, composition, 1K, 1/4W, 10%	R-0024
R24	Resistor, composition, 8.2K, 1/4W, 10%	R-0035
R25, R26	Same as R19	R-0034
R27	Same as R1	R-0030
R28	Same as R19	R-0034
R29	Resistor, composition, 470 ohms, 1/4W, 10%	R-0020
R30	Resistor, composition, 22K, 1/4W, 10%	R-0040
R31	Same as R5	R-0022
R32	Same as R1	R-0030
R33	Resistor, composition, 15K, 1/4W, 5%	R-1277
R34	Resistor, composition, 2.4K, 1/4W, 5%	R-1258
R36	Same as R1	R-0030
R37	Resistor, composition, 15K, 1/4W, 10%	R-0038
R38	Same as R3	R-0038
R39	Resistor, composition, 1.6K, 1/4W, 5%	R-1254
R40	Resistor, composition, 68 ohms, 1W, 10%	R-0210
R41	Same as R1	R-0030
R42	Resistor, composition, 1.5K, 1/4W, 10%	R-0026
T1	Transformer	162-0158
T2	Transformer	162-0162
T4	Same as T1	162-0158
Y1	Crystal, 1.1015 MHz	Y-0610
-06-	TRANSLATOR ASSEMBLY	162-0600
C1	Capacitor, ceramic, .1 uF, 25 VDCW	C-2210
C2	Capacitor, variable 7.25 pF	C-2304
C3	Same as C1	C-2210
C4	Capacitor, tantalum, 15 uF, 20 VDCW	162-0273
C5/C9	Same as C1	C-2210
C10	Capacitor, variable, 2.5-11 pF	C-2303
C11, C12	Same as C1	C-2210
C13	Same as C10	C-2303
C14/C16	Same as C1	C-2210
C17	Same as C4	162-0273
C18	Same as C1	C-2210
ENTER CHANGE DATA		

REF DESIG	DESCRIPTION	RF P/N
C19	Same as C2	C-2304
C20	Same as C10	C-2303
C21	Same as C1	C-2210
C22	Same as C10	C-2303
C23, C24	Same as C1	C-2210
C25	Same as C4	162-0273
C26	Same as C1	C-2210
C27	Same as C2	C-2304
C28	Capacitor, dipped-mica, 820 pF, 300 VDCW, 2%	C-2503
C29, C30	Same as C1	C-2210
C31	Capacitor, tantalum, 15 uF, 20 VDCW	162-0273
CR1/CR16	Diode, germanium, type 1N270	CR-0047
FL1	Filter, 17.748 MHz	FL-0108
FL2	Filter, 11.1414 MHz	FL-0106
J7/J11	Connector, receptacle	J-0031
L1	Inductor, 240 uH	L-0052
L2	Inductor, 390 uH	L-0075
L3/L6	Same as L1	L-0052
Q1, Q2	Transistor, type 2N3283	Q-0380
Q3, Q2	Transistor, type 2N998 4916	Q-0108 0360
R1	Resistor, composition, 2.7K, 1/4W, 10%	R-0029
R2	Resistor, composition, 1.5K, 1/4W, 10%	R-0026
R3	Resistor, composition, 47 ohms, 1/4W, 10%	R-0008
R4	Resistor, composition, 2.2K, 1/4W, 10%	R-0028
R5, R9	Resistor, composition, 300 ohms, 1/4W, 10%	R-0019 1249
R6	Same as R4	R-0028
R7	Resistor, composition, 560 ohms, 1/4W, 10%	R-0021
R8	Same as R1	R-0029
R9	Same as R2	R-0026
R10	Same as R3	R-0008
R11, 12	Resistor, composition, 1.5K, 1/4W, 10%	R-0026 1233
R12	Resistor, composition, 1.8K, 1/4W, 10%	R-0027
R13	Same as R1	R-0029
R14	Same as R4	R-0028
R15	Same as R3	R-0008
R16, R17	Resistor, composition, 1.2K, 1/4W, 10%	R-0025
R18	Resistor, composition, 15K, 1/4W, 10%	R-0038
R19	Resistor, composition, 5.6K 70K, 1/4W, 10%	R-0036 R-1267
R20	Same as R7	R-0021
T1	Transformer	162-0162
Y1	Crystal, 18.441 MHz	Y-0641
Z1	Ferrite Iron Bead	E-0652
-07-	IF AMPLIFIER ASSEMBLY	162-0700
C1	Capacitor, ceramic, .1 uF, 25 VDCW	C-2210
C2	Capacitor, tantalum, 15 uF, 20 VDCW	162-0273
C3	Same as C1	C-2210
C4	Capacitor, dipped-mica, 820 pF, 300 VDCW, 2%	C-2503
C5/C7	Same as C1	C-2210
C8	Same as C4	C-2503
ENTER CHANGE DATA		



REF DESIG	DESCRIPTION	RF P/N
C9/C11	Same as C1	C-2210
C12	Same as C4	C-2503
C13/C14	Same as C1	C-2210
C15	Same as C4	C-2503
C16/C22	Same as C1	C-2210
C23	Same as C4	C-2503
C24/C26	Same as C1	C-2210
C27	Same as C4	C-2503
C28	Same as C1	C-2210
C29	Same as C2	162-0273
C30, C31	Same as C1	C-2210
C32	Same as C4	C-2503
C33	Same as C2	162-0273
C34	Capacitor, tantalum, 220 uF, 10 VDCW	C-5850
C35	Same as C2	162-0273
C36/C38	Same as C1	C-2210
C39	Same as C2	162-0273
C40	Same as C1	C-2210
C41	Same as C1	C-2210
CR1/CR7	Diode, germanium, type 1N270	CR-0047
J22	Connector, receptacle, coax	J-0031
K1	Relay, SPDT, 12 V DC	K-0045
L1/L3	Inductor, 1 MH	L-0050
L4, L5	Inductor, 240 uH	L-0052
Q1/Q3	Transistor, type 2N1224	Q-0108
Q4, Q5	Transistor, type 2N4916	Q-0360
Q6	Same as Q1	Q-0108
Q7, Q8	Same as Q4	Q-0360
Q9	Transistor, type 2N3642	Q-0320
Q10	Transistor, type 2N1479	Q-0106
R1	Resistor, composition, 10K, 1/4W, 5%	R-1273
R2	Resistor, composition, 8.2K, 1/4W, 5%	R-1271
R3	Resistor, composition, 6.8K, 1/4W, 5%	R-1269
R4	Resistor, composition, 820 ohms, 1/4W, 10%	R-0023
R5	Resistor, composition, 220 ohms, 1/4W, 5%	R-1233
R6	Same as R1	R-1273
R7	Resistor, composition, 15K, 1/4W, 5%	R-1277
R8	Same as R4	R-0023
R9	Resistor, composition, 220 ohms, 1/4W, 10%	R-0016
R10, R11	Same as R1	R-1273
R12, R13	Same as R4	R-0023
R14	Resistor, composition, 130 ohms, 1/4W, 5%	R-1228
R15	Resistor, composition, 470 ohms, 1/4W, 5%	R-1241
R16	Potentiometer, 100 ohms, 1W	R-3109
R17	Resistor, composition, 3.3K, 1/4W, 10%	R-0030
R18	Resistor, composition, 2.7K, 1/4W, 10%	R-0029
R19	Resistor, composition, 1.0K, 1/4W, 10%	R-0024
R20	Resistor, composition, 390 ohms, 1/4W, 5%	R-1239
R21	Resistor, composition, 10 MEG, 1/4W, 10%	R-0072
R22	Same as R2	R-1271
R23	Resistor, composition, 1.5K, 10%	R-0026
ENTER CHANGE DATA		

REF DESIG	DESCRIPTION	RF P/N
R24	Resistor, composition, 10 ohms, 1/4W, 10%	R-0000
R25	Same as R17	R-0030
R26	Same as R18	R-0029
R27	Same as R19	R-0024
R28	Resistor, composition, 2.7K, 1/4W, 5%	R-1259
R29	Resistor, composition, 6.8K, 1/4W, 10%	R-0034
R30	Resistor, composition, 270 ohms, 1/4W, 5%	R-1235
R31, R32	Resistor, composition, 820 ohms, 1/4W, 5%	R-1247
R33	Same as R1	R-1273
R34	Resistor, composition, 4.7K, 1/4W, 5%	R-1265
R35	Potentiometer, 10K, 1W,	R-3104
R36, R37	Same as R17	R-0030
R38	Resistor, composition, 68 ohms, 1/4W, 5%	R-1221
R39	Potentiometer, 500 ohms, 1W	R-3100
R40	Same as R17	R-0030
R41	Resistor, composition, 15K, 1/4W, 10%	R-0038
R42	Same as R19	R-0024
R43	Resistor, composition, 1K, 1/4W, 10%	R-0024
R44	Resistor, composition, 10K, 1/4W, 10%	R-0036
R45	Resistor, composition, 390 ohms, 1/4W, 10%	R-0019
R46	Resistor, composition, 150 ohms, 1/4W, 10%	R-0014
R47	Same as R44	R-0036
R48	Same as R46	R-0014
R49	Same as R9	R-0016
R50	Resistor, composition, 47K, 1/4W, 10%	R-0044
R51	Resistor, composition, 390 ohms, 1/4W, 10%	R-0019
T1/T7	Coil Assembly	162-0162
-08- AUDIO/MODULATOR ASSEMBLY		162-0800
C19, C20	Capacitor, ceramic, .1 uF, 25 VDCW	C-2210
C21	Capacitor, dipped-mica, 620 pF, 300 VDCW, 2%	C-2500
C22	Same as C19	C-2210
C23	Capacitor, tantalum, 15 uF, 20 VDCW	162-0273
C24	Capacitor, tantalum, 33 uF, 20 VDCW	C-5839
C25, C26	Same as C23	162-0273
C27/C29	Capacitor, mylar, 4700 pF, 100 VDCW, 10%	C-2108
C30	Same as C23	162-0273
C31	Same as C24	C-5839
C32/C35	Same as C23	162-0273
C36	Capacitor, ceramic, .02 uF, 30 VDCW	C-0059
C37	Same as C23	162-0273
C39	Capacitor, tantalum, 68 uF, 15 VDCW	C-5844
C41	Capacitor, dipped-mica, 300 pF, 300 VDCW, 5%	C-0138
ENTER CHANGE DATA		



REF DESIG	DESCRIPTION	RF P/N
C42	Same as C19	C-2210
C44	Capacitor, .01 uF, 500 VDCW	C-0003
C45	Capacitor, ceramic, .01 uF, 150 VDCW	C-0065
C50	Same as C19	C-2210
C51	Capacitor, mylar, 22 uF, 10%	C-2601
C52	Same as C19	C-2210
C53	Capacitor, ceramic, 0.47 uF, 10 VDCW	C-0058
C56	Same as C44	C-0003
C57	Capacitor, .01 uF, 50 VDCW	C-4952
C58	Capacitor, variable, 1-38 pF	C-2563
C59	Capacitor, 91 pF, 2%	C-2478
C60	Capacitor, 120 pF, 2%	C-2481
C61/C64	Same as C41	C-2503
C65	Same as C51	C-2601
C66	Same as C19	C-2210
C67	Same as C41	C-2503
C68	Same as C19	C-2210
C69	Same as C45	C-0065
C70	Same as C45	C-0065
CR2/CR5	Diode, germanium, type 1N270	CR-0047
CR6	Diode, silicon, type 1N4454	CR-0705
CR7, CR8	Same as CR2	CR-0047
CR9	Diode, zener, type 1N4739A	CR-0351
CR10/CR14	Same as CR6	CR-0705
J24/J25	Connector, receptacle	J-0031
L2	Choke, RF, 1 MH	L-0050
L4	Inductor, transformer	162-0165
P23	Connector, right-angle, multi-pin	P-0340
Q3	Transistor, type 2N4916	Q-0360
Q4	Transistor, type 2N652	Q-0020
Q5	Transistor, type 2N3644	Q-0315
Q6/Q8	Same as Q4	Q-0020
Q9	Transistor, type 2N3638	Q-0306
Q10	Transistor, type 2N4916	Q-0360
R1	Resistor, composition, 1K, 1/4W, 10%	R-0024
R17	Resistor, composition, 3.3K, 1/4W, 10%	R-0030
R18, R19	Resistor, composition, 1.5K, 1/4W, 10%	R-0026
R20	Resistor, composition, 6.8K, 1/4W, 10%	R-0034
R21	Resistor, composition, 2.2K, 1/4W, 10%	R-0028
R22	Same as R17	R-0030
R23	Resistor, composition, 820 ohms, 1/4W, 10%	R-0023
R24	Same as R18	R-0026
R25	Resistor, composition, 15K, 1/4W, 10%	R-0038
R26	Resistor, composition, 560 ohms, 1/4W, 10%	R-0021
R27	Resistor, composition, 82 ohms, 1/4W, 10%	R-0011
R28	Same as R25	R-0038
R29	Resistor, composition, 15K, 1/4W, 5%	R-1277
R30	Thermistor, 1K at 25°C	R-3167
R31	Resistor, composition, 12K, 1/4W, 10%	R-0037
R32	Resistor, composition, 56K, 1/4W, 10%	R-0045
R33	Resistor, composition, 2.2K, 1/4W, 10%	R-0028
ENTER CHANGE DATA		

REF DESIG	DESCRIPTION	RF P/N
R34	Same as R20	R-0034
R35	Resistor, composition, 1.8K, 1/4W, 10%	R-0027
R36	Resistor, composition, 5.6K, 1/4W, 10%	R-0033
R37	Same as R17	R-0030
R38	Resistor, composition, 8.2K, 1/4W, 10%	R-0035
R39	Same as R21	R-0028
R40	Resistor, composition, 33 ohms, 1/4W, 10%	R-0006
R41	Same as R26	R-0021
R42	Resistor, composition, 3.3K, 1/4W, 5%	R-1261
R43	Same as R26	R-0021
R44	Same as R35	R-0027
R45	Resistor, composition, 22K, 1/4W, 10%	R-0040
R46	Resistor, composition, 33 ohms, 1/4W, 10%	R-0006
R47	Resistor, composition, 100 ohms, 1W, 5%	R-1625
R48	Same as R17	R-0030
R50	Resistor, composition, 2.7K, 1/4W, 10%	R-0029
R51	Resistor, composition, 3.9K, 1/4W, 10%	R-0031
R52	Resistor, composition, 15 ohms, 1/4W, 10%	R-0002
R53	Resistor, composition, 100 ohms, 1W, 10%	R-0212
R54, R55	Resistor, 100 ohms, 1%	R-3741
R56	Resistor, variable, 500 ohms, 1W, 10%	R-3106
R57, R58	Resistor, 681 ohms, 1%	R-3743
R59/R62	Same as R54	R-3741
R63, R64	Resistor, 221 ohms, 1%	R-3742
R65, R66	Resistor, 5620 ohms, 1%	R-3744
R67	Same as R21	R-0028
R68	Resistor, composition, 270 ohms, 1/4W, 10%	R-0017
R69	Resistor, composition, 1.2K, 1/4W, 10%	R-0025
R70	Same as R17	R-0030
R71	Resistor, composition, 2.7K, 1/4W, 10%	R-0029
R72	Resistor, composition, 10K, 1/4W, 10%	R-0036
T3, T5	Transformer	162-0811
T6	Transformer	162-0162
T7	Transformer	162-0166
T8	Transformer	162-0162
-09-	VFO ASSEMBLY	162-0901
C1	Capacitor, variable, .8-18 pF	C-2561
C2	Capacitor, ceramic, .1 uF, 25 VDCW	C-2210
C3	Capacitor, porcelain, 190 pF, 300 VDCW, 2%	C-2308
C4	Capacitor, dipped-mica, 8200 pF, 500 VDCW, 5%	C-0176
C5	Same as C2	C-2210
C6	Capacitor, tantalum, 15 uF, 20 VDCW	162-0273
C7	Same as C2	C-2210
ENTER CHANGE DATA		



REF DESIG	DESCRIPTION	RF P/N
C8	Capacitor, mylar, .0047 uF, 100 VDCW	C-2108
C9	Same as C2	C-2210
C10	Same as C8	C-2108
C11	Capacitor, dipped-mica, 430 pF, 500 VDCW, 5%	C-2495
C12	Capacitor, ceramic, 81 pF, 500 VDCW, 2%	C4049
C13	Capacitor, variable, 1.8-15 pF	C-4064
C14	Same as C6	162-0273
CR1	Diode, zener, type 1N4737A	CR-0073
L1	Coil	L-0510
L2	Coil Assembly	162-0163
Q1/Q4	Transistor, type 2N4916	Q-0360
R1, R2	Resistor, composition, 1K, 1/4W, 10%	R-0024
R3	Resistor, composition, 3.3K, 1/4W, 10%	R-0030
R4	Resistor, composition, 2.7K, 1/4W, 10%	R-0029
R5	Resistor, composition, 8.2K, 1/4W, 10%	R-0035
R6	Resistor, composition, 220 ohms, 1/4W, 10%	R-0016
R7	Potentiometer, 500 ohms, 1W, 10%	R-3361
R8	Same as R3	R-0030
R9	Resistor, composition, 15K, 1/4W, 10%	R-0038
R10	Resistor, composition, 470 ohms, 1/4W, 10%	R-0020
R11	Resistor, composition, 100 ohms, 1/4W, 10%	R-0012
R12	Resistor, composition, 220 ohms, 1/4W, 10%	R-0016
R13	Same as R3	R-0030
R14	Resistor, composition, 10K, 1/4W, 10%	R-0036
R15	Same as R1	R-0024
R16	Resistor, composition, 39 ohms, 1/4W, 10%	R-0007
R17	Resistor, composition, 56 ohms, 1/4W, 10%	R-0009
R18	Resistor, composition, 3.9K, 1/4W, 10%	R-0031
T1	Coil Assembly	162-0158
-10-	MEGAHERTZ OSCILLATOR ASSEMBLY	162-1000
C1/C4	Capacitor, variable, 7-25 pF	C-2301
C5	Capacitor, variable, 2.5-11 pF	C-2300
C6	Capacitor, ceramic, temp compensating, 27 pF, 5%, 500 VDCW, N750	C-1375
C7	Capacitor, ceramic, .1 uF, 25 VDCW	C-2210
C8	Capacitor, dipped-mica, 270 pF, 5%, 500 VDCW	C-0137
C9	Capacitor, dipped-mica, 100 pF, 5%, 500 VDCW	C-0152
C10	Capacitor, dipped-mica, 68 pF, 5%, 500 VDCW	C-0122
C11, C12	Same as C7	C-2210
C13	Same as C8	C-0137
C14	Capacitor, ceramic, .01 uF, 400 VDCW	C-0065
ENTER CHANGE DATA		

REF DESIG	DESCRIPTION	RF P/N
C15, C16 C17, C18	Same as C7 Capacitor, ceramic, .001 uF, 500 VDCW	C-2210 C-0001
L1	Inductor, 47 uH	L-0060
L2	Inductor, 1000 uH	L-0050
Q1	Transistor, type 2N4916	Q-0360
Q2/Q4	Transistor, type 2N3904	Q-0361
R1, R2	Resistor, composition, 15K, 1/4W, 10%	R-0038
R3	Resistor, composition, 2.2K, 1/4W, 10%	R-0028
R4	Resistor, composition, 330 ohms, 1/4W, 10%	R-0018
R6, R7	Resistor, composition, 12K, 1/4W, 10%	R-0037
R8	Resistor, composition, 1K, 1/4W, 10%	R-0024
R9, R10	Resistor, composition, 47 ohms, 1/4W, 10%	R-0008
R11	Resistor, composition, 68 ohms, 1/4W, 10%	R-0010
R12	Resistor, composition, 82 ohms, 1/4W, 10%	R-0011
R13	Resistor, composition, 470 ohms, 1/4W, 10%	R-0020
R14	Resistor, composition, 390 ohms, 1/4W, 10%	R-0019
R15	Resistor, composition, 220 ohms, 1/4W, 10%	R-0016
S1	Switch	162-1003
Y1	Crystal, 3.247 MHz	Y-0450
Y2	Crystal, 4.247 MHz	Y-0451
Y3	Crystal, 5.247 MHz	Y-0452
Y4	Crystal, 6.247 MHz	Y-0455
Y5	Crystal, 7.247 MHz	Y-0464
Y6	Crystal, 8.247 MHz	Y-0465
Y7	Crystal, 9.247 MHz	Y-0466
Y8	Crystal, 10.247 MHz	Y-0467
Y9	Crystal, 11.247 MHz	Y-0468
Y10	Crystal, 12.247 MHz	Y-0469
Y11	Crystal, 13.247 MHz	Y-0470
Y12	Crystal, 14.247 MHz	Y-0471
Y13	Crystal, 15.247 MHz	Y-0472
-11-	100 kHz OSCILLATOR ASSEMBLY	162-1150
C1	Capacitor, dipped-mica, 270 pF, 500 VDCW, 5%	C-0137
C2	Capacitor, dipped-mica, 82 pF, 500 VDCW, 5%	C-0124
C3	Capacitor, variable, 7-25 pF	C-2304
C4	Capacitor, dipped-mica, 33 pF, 500 VDCW, 5%	C-0113
C5, C6	Capacitor, ceramic, .1 uF, 25 VDCW	C-2210
C7	Capacitor, dipped-mica, 160 pF, 500 VDCW, 5%	C-0131
C8	Same as C5	C-2210
C9	Capacitor, dipped-mica, 820 pF, 300 VDCW, 2%	C-2503
C10	Capacitor, dipped-mica, 1000 pF, 300 VDCW, 2%	C-2505
L1	Inductor, 240 uH	L-0052
L2	Inductor, 1 uH	L-0054
Q1	Transistor, type 2N4916	Q-0360
Q2	Transistor, type 2N4124	Q-0385
ENTER CHANGE DATA		



REF DESIG	DESCRIPTION	RF P/N
R1	Resistor, composition, 15K, 1/4W, 5%	R-1277
R2	Resistor, composition, 2.2K, 1/4W, 5%	R-1257
R3	Resistor, composition, 12K, 1/4W, 5%	R-1275
R4	Resistor, composition, 10 ohms, 1/4W, 5%	R-1201
R5	Resistor, composition, 390 ohms, 1/4W, 5%	R-1239
R6	Same as R3	R-1275
R7, R8	Resistor, composition, 470 ohms, 1/4W, 5%	R-1241
R9	Same as R1	R-1277
R10	Resistor, composition, 270 ohms, 1/4W, 5%	R-1235
R11	Resistor, composition, 220 ohms, 1/4W, 5%	R-1233
S1	Switch wafer	162-1160
Y1	Crystal, 6.147 MHz	Y-0453
Y2	Crystal, 6.247 MHz	Y-0454
Y3	Crystal, 6.347 MHz	Y-0456
Y4	Crystal, 6.447 MHz	Y-0457
Y5	Crystal, 6.547 MHz	Y-0458
Y6	Crystal, 6.647 MHz	Y-0459
Y7	Crystal, 6.747 MHz	Y-0460
Y8	Crystal, 6.847 MHz	Y-0461
Y9	Crystal, 6.947 MHz	Y-0462
Y10	Crystal, 7.047 MHz	Y-0463
-12-	10 kHz OSCILLATOR ASSEMBLY	162-1210
C1	Capacitor, mylar, .0015 uF, 100 VDCW	C-2102
C2	Capacitor, ceramic, .01 uF, 50 VDCW	C-4952
C5, C6	Same as C1	C-2102
C7, C8	Capacitor, ceramic, .1 uF, 25 VDCW	C-2210
L1, L2	Inductor, 4.7 uH	L-0056
L3	Inductor, 240 uH	L-0052
Q1	Transistor, type 2N4916	Q-0360
Q2	Transistor, type 2N4124	Q-0385
R1	Resistor, composition, 2.7K, 1/4W, 5%	R-1259
R2	Resistor, composition, 680 ohms, 1/4W, 5%	R-1245
R3	Resistor, composition, 39 ohms, 1/4W, 5%	R-1215
R4	Resistor, composition, 22K, 1/4W, 5%	R-1281
R5	Resistor, composition, 2.2K, 1/4W, 5%	R-1257
R6	Resistor, composition, 5.6K, 1/4W, 5%	R-1267
R7	Resistor, composition, 390 ohms, 1/4W, 5%	R-1239
R8	Resistor, composition, 820 ohms, 1/4W, 5%	R-1247
R9	Resistor, composition, 10 ohms, 1/4W, 5%	R-1201
S1	Switch wafer	162-1165
Y1	Crystal, 1.7565 MHz	Y-0600
Y2	Crystal, 1.7665 MHz	Y-0601
Y3	Crystal, 1.7765 MHz	Y-0602
Y4	Crystal, 1.7865 MHz	Y-0603
Y5	Crystal, 1.7965 MHz	Y-0604
ENTER CHANGE DATA		

REF DESIG	DESCRIPTION	RF P/N
Y6	Crystal, 1.8065 MHz	Y-0605
Y7	Crystal, 1.8165 MHz	Y-0606
Y8	Crystal, 1.8265 MHz	Y-0607
Y9	Crystal, 1.8365 MHz	Y-0608
Y10	Crystal, 1.8465 MHz	Y-0609
-13-	1 kHz OSCILLATOR ASSEMBLY	162-1300
C1, C2	Capacitor, ceramic, .01 uF, 150 VDCW	C-0065
C3	Capacitor, paper, .22 uF, 50 VDCW	C-2601
C4	Capacitor, dipped-mica, 75 pF, 500 VDCW, 5%	C-0123
C5	Capacitor, ceramic, .1 uF, 150 VDCW	C-0063
C6	Same as C1	C-0065
C7, C8	Capacitor, dipped-mica, 100 pF, 500 VDCW, 5%	C-0126
C9	Capacitor, ceramic, .001 uF, 500 VDCW	C-0001
C10	Capacitor, dipped-mica, 43 pF, 500 VDCW, 5%	C-0116
C11	Capacitor, dipped-mica, 160 pF, 500 VDCW, 5%	C-0131
C12	Capacitor, dipped-mica, 200 pF, 500 VDCW, 5%	C-0133
C13	Capacitor, dipped-mica, 43 pF, 500 VDCW, 5%	C-0116
CR1, CR2	Diode, germanium, type 1N270	CR-0047
L1, L2	Inductor, 390 uH	L-0075
L3	Inductor, 100 uH	L-0051
L4	Inductor, 2.7 uH	L-0077
L5	Same as L3	L-0051
Q1	Transistor, 2N4916	Q-0360
Q2	Transistor, 2N3904	Q-0361
Q3, Q4	Same as Q1	Q-0360
Q5, Q6	Same as Q2	Q-0361
R1	Resistor, composition, 15K, 1/4W, 10%	R-0038
R2	Resistor, composition, 2.2K, 1/4W, 10%	R-0028
R3	Same as R1	R-0038
R4	Resistor, composition, 330 ohms, 1/4W, 10%	R-0018
R5	Resistor, composition, 1K, 1/4W, 10%	R-0024
R7	Resistor, composition, 8.2K, 1/4W, 10%	R-0035
R8	Resistor, composition, 470 ohms, 1/4W, 10%	R-0020
R9/R10	Resistor, composition, 6.8K, 1/4W, 10%	R-0034
R11/R12	Resistor, composition, 10K, 1/4W, 10%	R-0036
R13	Resistor, composition, 1.5K, 1/4W, 10%	R-0026
R14	Resistor, composition, 330 ohms, 1/4W, 10%	R-0018
R15	Same as R13	R-0026
R16	Resistor, composition, 3.3K, 1/4W, 10%	R-0030
R17	Same as R11	R-0036
R18	Resistor, composition, 6.8K, 1/4W, 10%	R-0034
R19	Same as R14	R-0018
ENTER CHANGE DATA		



REF DESIG	DESCRIPTION	RF P/N
R20	Resistor, composition, 47 ohms, 1/4W, 10%	R-0008
R21	Resistor, composition, 22 ohms, 1/4W, 10%	R-0004
R22	Resistor, composition, 270 ohms, 1/4W, 10%	R-0017
S1	Switch	162-1308
Y1	Crystal, 1579.0 kHz	Y-0651
Y2	Crystal, 1581.0 kHz	Y-0642
Y3	Crystal, 1583.0 kHz	Y-0643
Y4	Crystal, 1585.0 kHz	Y-0644
Y5	Crystal, 1587.0 kHz	Y-0645
Y6	Crystal, 1589.0 kHz	Y-0646
Y7	Crystal, 1591.0 kHz	Y-0647
Y8	Crystal, 1593.0 kHz	Y-0648
Y9	Crystal, 1595.0 kHz	Y-0649
Y10	Crystal, 1597.0 kHz	Y-0650
-15-	ALC CIRCUIT ASSEMBLY	162-1500
C1	Capacitor, ceramic, .001 uF, 10%, 500 VDCW	C-0001
C2	Capacitor, Electrolytic, 15 uF, 20%, 20 VDCW	C-5832
C3	Capacitor, Film, .22 uF, 20%, 200 VDCW	C-0820
C4	Capacitor, Tantalum, 10 uF, 20%, 10 VDCW	C-6327
C5	Capacitor, Tantalum, 22 uF, 20%, 25 VDCW	C-6439
CR1	Diode, type 1N4454	CR-0705
CR2	Diode, type 1N4454	CR-0705
CR3	Diode, type 1N4004	CR-0725
CR4	Diode, type 1N4004	CR-0725
Q1	Transistor, type 2N4916	Q-0360
Q2	Transistor, type 2N3904	Q-0361
R1	Resistor, composition, 6.8K, 1/4W, 5%	R-1269
R2	Resistor, composition, 150K, 1/4W, 5%	R-1301
R3	Resistor, composition, 100 ohms, 1/4W, 5%	R-1225
R4	Resistor, composition, 390K, 1/4W, 5%	R-1311
R5	Resistor, composition, 150K, 1/4W, 5%	R-1301
R6	Resistor, composition, 47K, 1/4W, 5%	R-1289
R7	Resistor, composition, 100 ohms, 1/4W, 5%	R-1225
-16-	ACC CIRCUIT ASSEMBLY	162-1600
C1	Capacitor, tantalum, 33 uF, 20 VDCW	C-5839
C2	Capacitor, tantalum, 15 uF, 20 VDCW	162-0273
C3	Capacitor, ceramic, .1 uF, 25 VDCW	C-2210
CR1	Diode, silicon, type 1N4001	CR-0043
Q1	Transistor, type 2N3565	Q-0311
Q2	Transistor, type 2N3565	Q-0311
R1	Resistor, composition, 3.3K, 1/4W, 10%	R-0030
ENTER CHANGE DATA		

REF DESIG	DESCRIPTION	RF P/N
R2	Resistor, composition, 8.2K, 1/4W, 10%	R-0035
R3	Resistor, composition, 270 ohms, 1/4W, 10%	R-0017
R4	Resistor, composition, 150 ohms, 1/4W, 10%	R-0014
R5	Resistor, composition, 15K, 1/4W, 10%	R-0038
R6	Potentiometer, 500 ohms, 1W, 10%	R-3361
R7	Resistor, composition, 1.2K, 1/4W, 10%	R-0025
R8	Resistor, composition, 1.5K, 1/4W, 10%	R-0026
R9	Resistor, composition, 2.2K, 1/4W, 10%	R-0028
-17-	AUDIO AMPLIFIER ASSEMBLY	162-1700
C1	Capacitor, tantalum, 15 uF, 20 VDCW	162-0273
C2	Capacitor, ceramic, 0.47 uF, +85-20%, 10 VDCW	C-0058
C3	Capacitor, tantalum, 33 uF, 20%, 10 VDCW	C-5838
C4	Capacitor, electrolytic, 580 uF, 15 VDCW	C-4162
C5	Capacitor, plastic, .022 uF, 100 VDCW, 10%	C-2116
C6, C7	Capacitor, ceramic, .01 uF, 150 VDCW	C-0065
C8	Same as C1	162-0273
C9	Capacitor, ceramic, .022 +60% -40%; 150 VDCW	C-3306
CR1	Diode, silicon, type 1N4454	CR-0705
CR2	Diode, type 1N270	CR-0047
Q1	Transistor, type 2N3642	Q-0320
Q2	Transistor, type 2N3638	Q-0306
Q3	Same as Q1	Q-0320
Q4	Same as Q2	Q-0306
Q5	Transistor, type 2N4918	Q-0337
Q6	Transistor, type 2N4921	Q-0334
R1	Resistor, composition, 8.2K, 1/2W, 5%	R-1471
R2	Resistor, composition, 10K, 1/2W, 5%	R-1473
R3	Resistor, composition, 3.3K, 1/2W, 5%	R-1461
R4	Resistor, composition, 1.5K, 1/2W, 10%	R-0126
R5	Resistor, composition, 100 ohms, 1/2W, 10%	R-0112
R7	Resistor, composition, 1K, 1/2W, 5%	R-1449
R8	Resistor, composition, 1K, 1/2W, 10%	R-0124
20-23	FREQUENCY STANDARD	
(20)	Frequency Standard, (1 part in 10 ⁶)	591-2060
ENTER CHANGE DATA		



REF DESIG	DESCRIPTION	RF P/N
RF-303	13.5 VDC POWER MODULE	162-1850
C1	DC Power Cable, 15 foot Capacitor, mylar, 0.47 uF, 100 VDCW	162-1812 C-0809
C2,C3	Capacitor, tantalum, 150 uF, 30 VDCW	C-2851
C4, C5	Capacitor, ceramic, .01 uF, 500 VDCW	C-0003
CR1,CR2	Diode, silicon, type 1N4001	CR-0043
F1	Fuse, 25A	F-0019
K1	Relay, 12 VDC	K-0048
Q1, Q2	Transistor, type MHT-1851	Q-0316
R1	Resistor, wirewound, 2.7 ohms, 10W	R-3200
R2	Resistor, wirewound, 1.5 ohms, 10W	R-3214
R3	Resistor, composition, 82 ohms, 2W, 10%	R-0311
T1	Transformer, power	162-0170
RF-304	26.0 VDC POWER MODULE	162-1800
C1/C3	DC Power Cable, 15 foot Capacitor, tantalum, 150 uF, 30 VDCW	162-1812 C-2851
C4	Capacitor, ceramic; 0.1 uF, 75 VDCW	C-0063
CR1/CR3	Diode, silicon, type 1N4001	CR-0043
CR4, CR5	Diode, silicon, type 3A100	CR-0072
CR6, CR7	Diode, silicon, type 1N2071	CR-0001
CR8	Diode, zener, type 1N1371A	CR-0041
CR9/CR12	Same as CR1	CR-0043
K1	Relay, 24 VDC	K-0047
Q1, Q2	Transistor type DST 9743	Q-0358
R1	Resistor, composition, 1.5K, 1/2W, 10%	R-0126
R2	Resistor, composition, 10K, 1W, 10%	R-0236
R3	Resistor, wirewound 2.7 ohms, 10W	R-3200
R4	Resistor, wirewound, 1.5 ohms, 10W	R-3214
R5, R6	Resistor, composition, 4.7 ohms, 1/4W, 10%	R-0077
R7	Potentiometer, 100 ohms, 5W, 10%	162-1818
T1	Transformer power	162-0171
055	RECEIVER PROTECTOR	162-0550
C1	Capacitor, feedthrough, 2400 pF	162-0270
C2	Capacitor, tantalum, 220 uF, 10 VDCW	C-5850
C3	Capacitor, ceramic, .005 uF, VDCW	C-0002
CR1/CR3	Diode, silicon, type 1N4454	CR-0705
K1	Relay, DPDT, 12 VDC	K-0065
L1	Inductor, 33 uH	L-0088
Q1	Transistor, type 2N3904	Q-0361
Q2	Transistor, type 2N3904	Q-0361
ENTER CHANGE DATA		

REF DESIG	DESCRIPTION	RF P/N
R1	Resistor, composition, 10K, 2W, 10%	R-0336
R2	Resistor, Composition, 10K, 1/4W, 10%	R-0036
R3	Resistor, composition, 18K, 1/4W, 10%	R-0039
R4	Resistor, composition, 4.7K, 1/4W, 10%	R-0032
R5	Resistor, composition, 10 ohms, 1/W, ±10%	R-0000
R6	Resistor, composition, 5.6K, 1/4W, 10%	R-0033
R7	Resistor, composition, 1.2K, 1/4W, 10%	R-0025
ACCESSORIES		
RF-103	1KW Linear Amplifier	426-0000
RF-302	Manual Antenna Coupler	162-2100
RF-302R	Remote Controlled Antenna Coupler	
RF-305	Shockmount Base for RF-301 and RF-302	162-0010
RF-305A	Shockmount Base for RF-301 only	425-0005
-	Air Filter for RF-305 and 305A	162-2005
RF-305B	Shockmount Base for RF-302 only	425-0006
RF-306	Air Filter Assembly for use directly with RF-301	162-0025
RF-307	Remote Control Unit	356-0000
RF-308	Running Spare Parts Kit	162-2251
RF-309	Depot Spare Parts Kit	162-2252
RF-311	Comprehensive Spare Parts Kit	162-2253
RF-318	Extension Cable Test Set	162-3000
RF-319	CW Hand Key	
RF-334A	Doublet Antenna Kit	162-2700
RF-3001	Headset	591-2752
RF-3002	Headset with boom microphone	591-2753
RF-3005	Two Way Audio Adapter	591-2754
SB-V9	Vertical 9 foot Whip Antenna Kit	
SB-V16	Vertical 16 foot fiberglass Whip Antenna Kit (feedthrough base)	100-0190
SB-V16	Vertical 16 foot fiberglass Whip Antenna Kit (flange base)	100-0191
SB-V16A	Vertical 16 foot fiberglass Whip Antenna Kit	100-3000
SB-V35	Vertical 35 foot fiberglass Whip Antenna Kit (feedthrough base)	100-0192
SB-V35	Vertical 35 foot fiberglass Whip Antenna Kit (flange base)	100-0193
SB-V35A	Vertical 35 foot aluminum Whip Antenna Kit	100-3002
SB-A75/150	75 foot or 150 foot Long Wire Antenna Kit	100-0125
REPLACEMENT HARDWARE		
-	Case (RF-301 only)	162-0111
-	Case (RF-301A only)	425-0111
-	Front handles (RF-301 only)	H-4287
ENTER CHANGE DATA		

Antennas: see DMH018-1



REF DESIG	DESCRIPTION	RF P/N
-	Rear handle	H-4286
-	1kHz Knob	162-0066
-	10 kHz Knob	162-0065
-	100 kHz Knob	162-0065
-	1000 kHz Knob	162-0064
-	FUNCTION Knob	MP-1080
-	RF GAIN Knob	MP-0000
-	TRANSMIT AUDIO Knob	MP-0000
-	RECEIVE AUDIO Knob	MP-0000
ENTER CHANGE DATA		

REF DESIG	DESCRIPTION	RF P/N
-	PA TUNE Knob	MP-1081
-	PA TUNE Skirt	162-0067
-	PRESELECTOR Knob	MP-1081
-	PRESELECTOR Skirt	162-0067
-	Locking thumbscrew	162-0333
-	Skirt washer	162-0332
-	PA Top cover plate	162-0083
-	Microphone assembly, dynamic	162-0020
ENTER CHANGE DATA		

Figure 4.6 Signal Block Diagram.

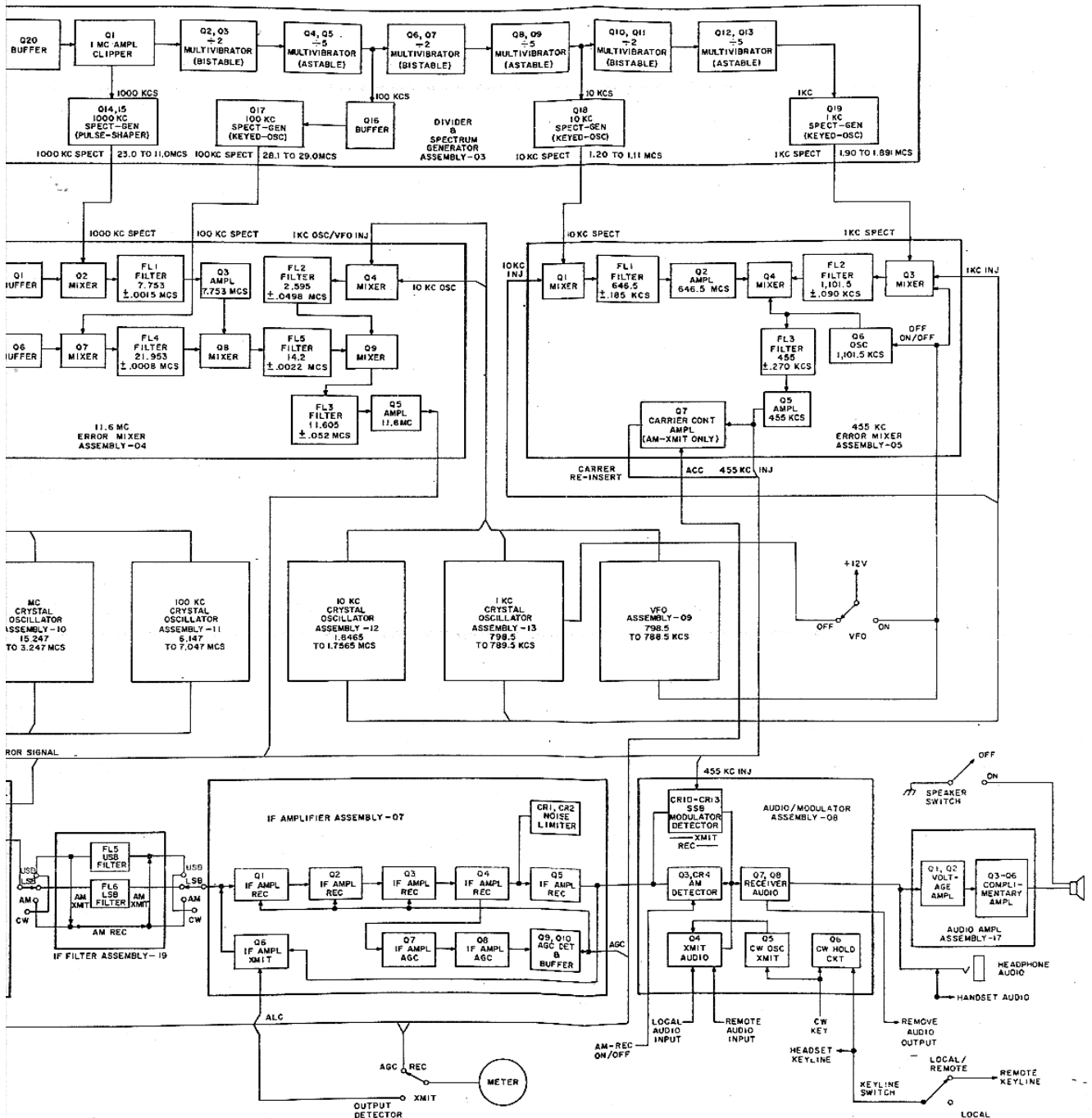

Figure 4.6 – RF-301 Signal Block Diagram

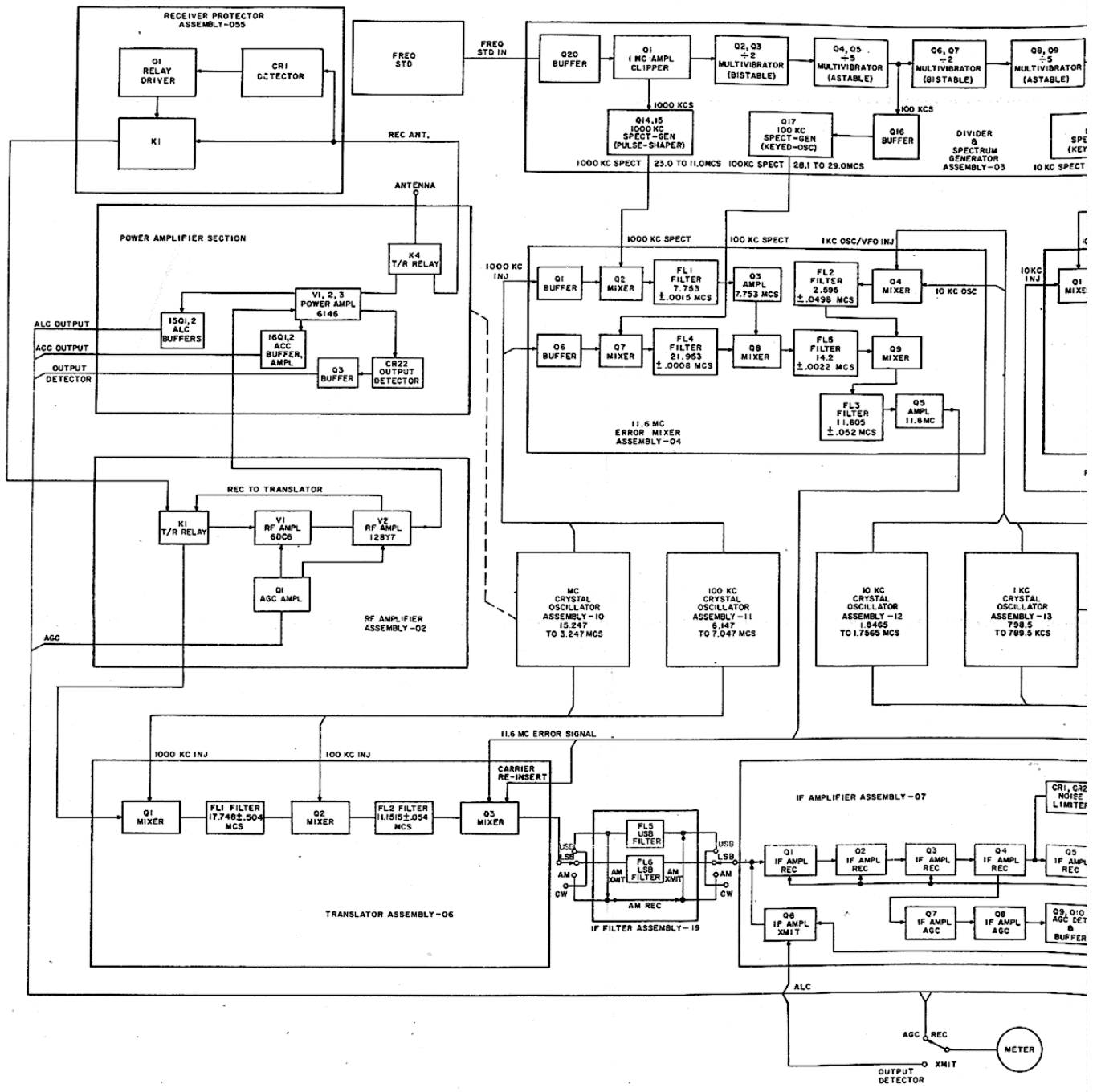
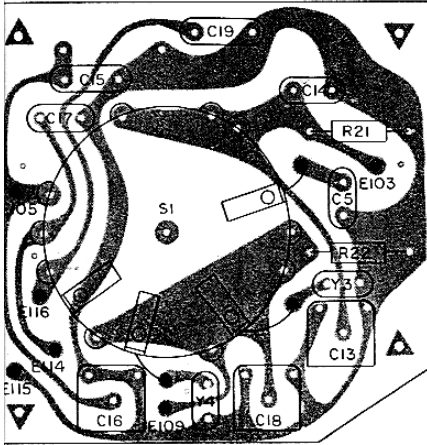
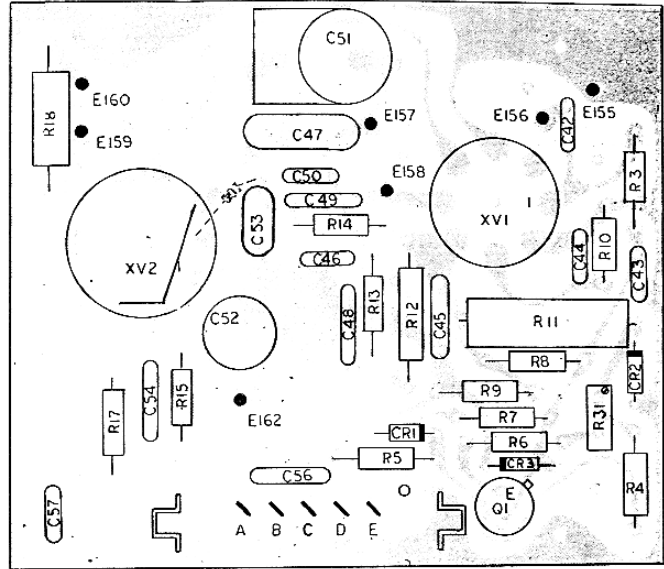

Figure 8.1 RF Amplifier Parts Location.



Bandswitch – Sect. B (162-0207)



RF Amplifier (162-0260)

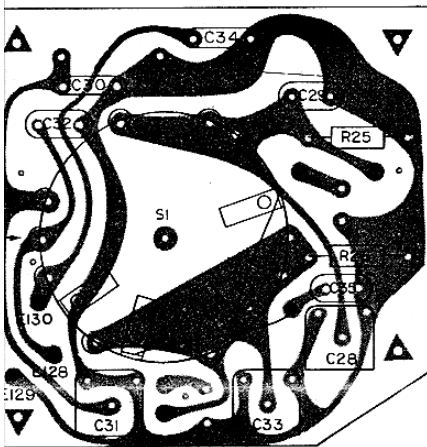

Bandswitch – Sect. D (162-0209)

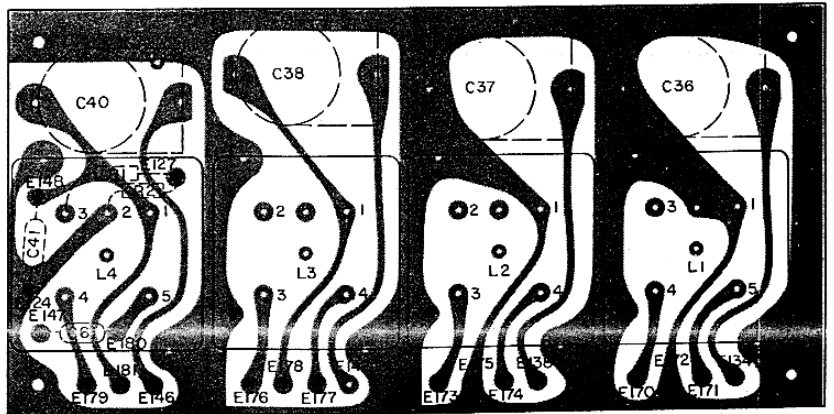

Coil Board (162-0250)

Figure 8.1 – RF Amplifier Parts Location

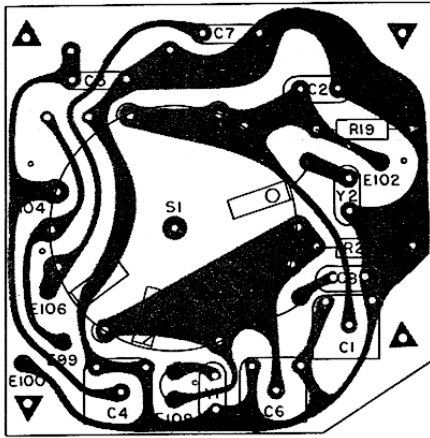

Bandswitch – Sect. A (162-0206)

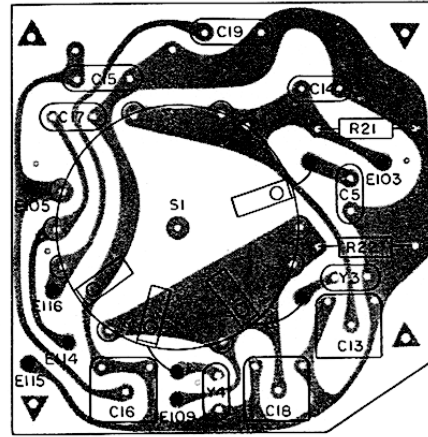

Bandswitch – Sect. B (162-0207)

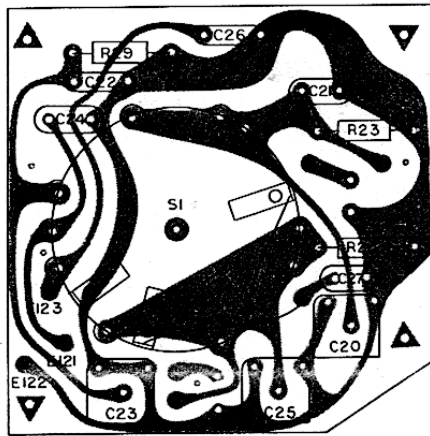
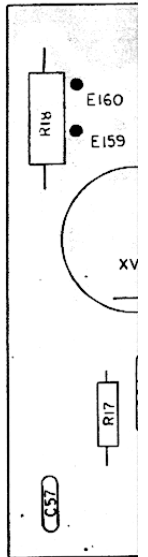

Bandswitch – Sect. C (162-0208)

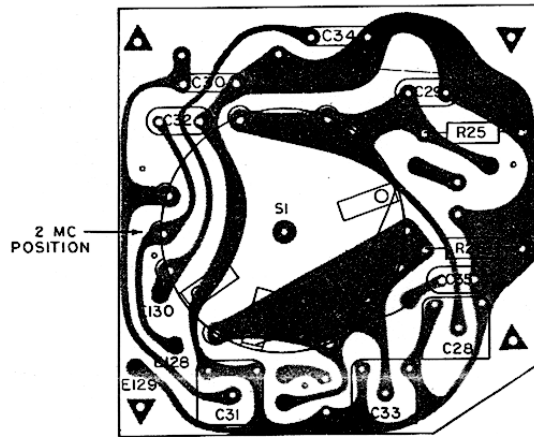

Bandswitch – Sect. D (162-0209)

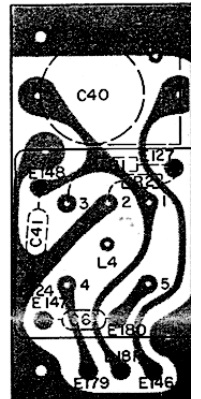

Figure 8.1 – RF Amplifier Parts Location

Figure 8.2 RF Amplifier Schematic Diagram.

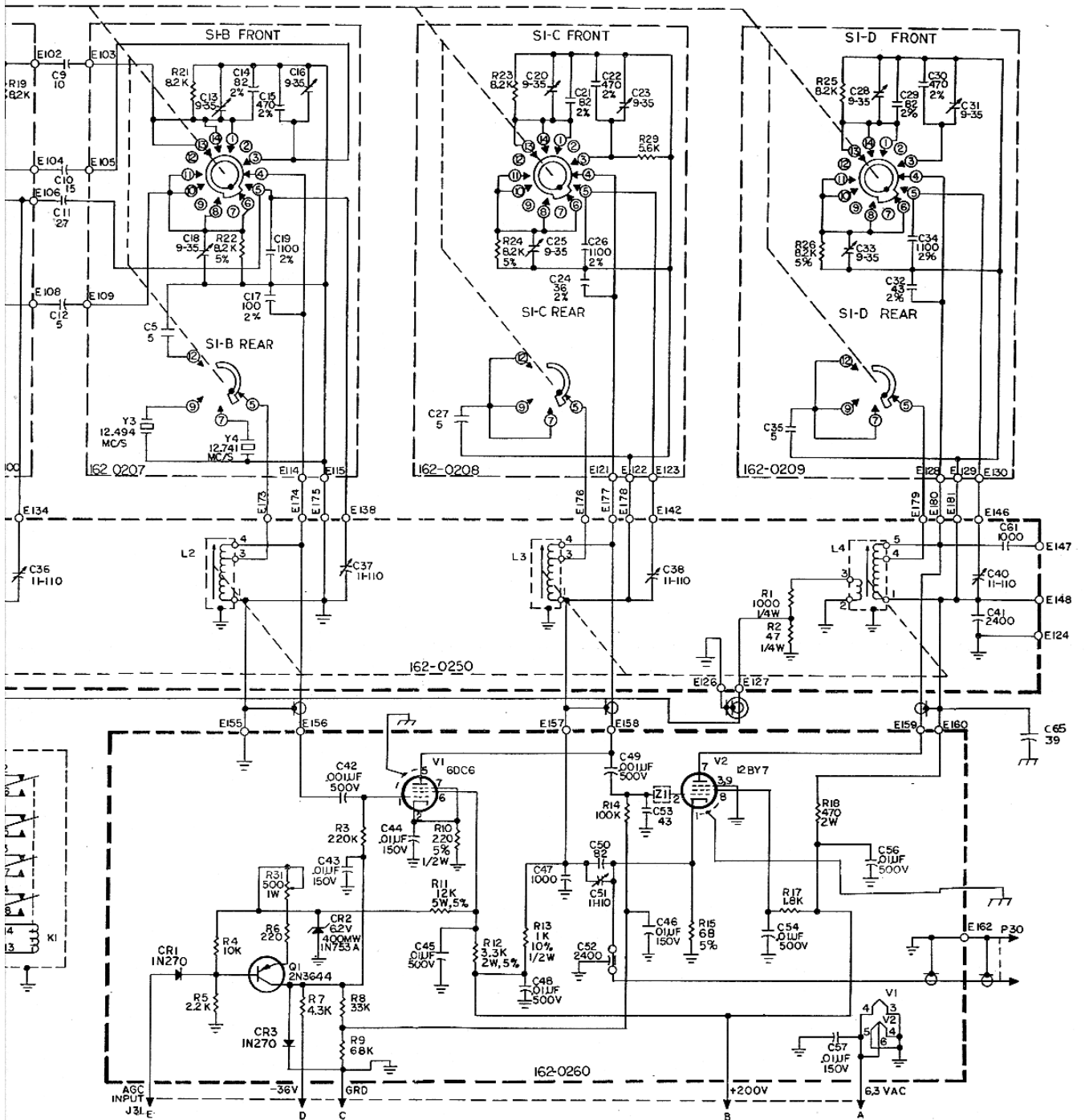
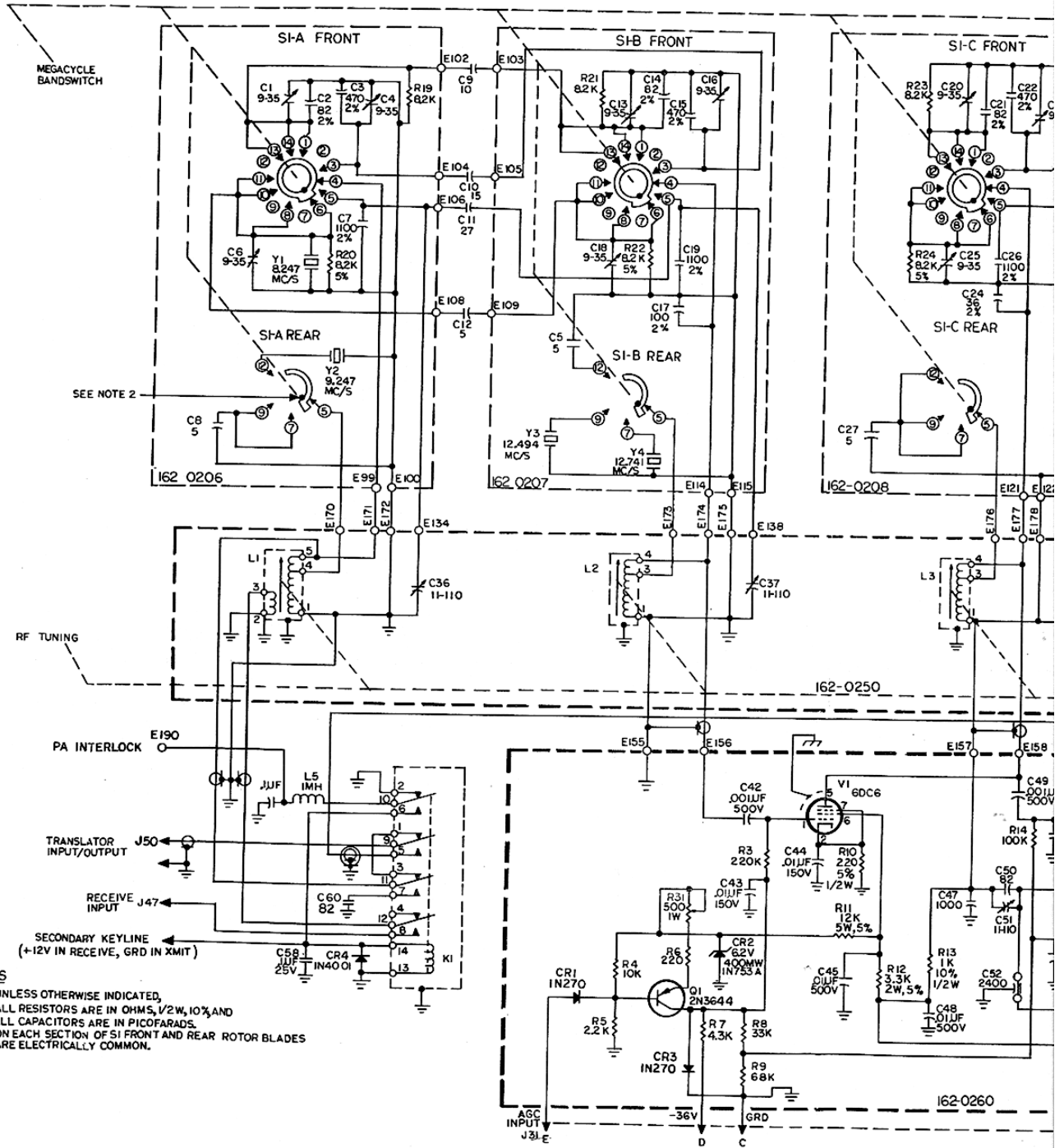

Figure 8.2 – RF Amplifier Schematic Diagram



NOTES
1 UNLESS OTHERWISE INDICATED,
ALL RESISTORS ARE IN OHMS, 1/2W, 10% AND
ALL CAPACITORS ARE IN PICOFARADS.
2 ON EACH SECTION OF SI FRONT AND REAR ROTOR BLADES
ARE ELECTRICALLY COMMON.

Figure 8.3 Divider/Spectrum Generator Parts Location.

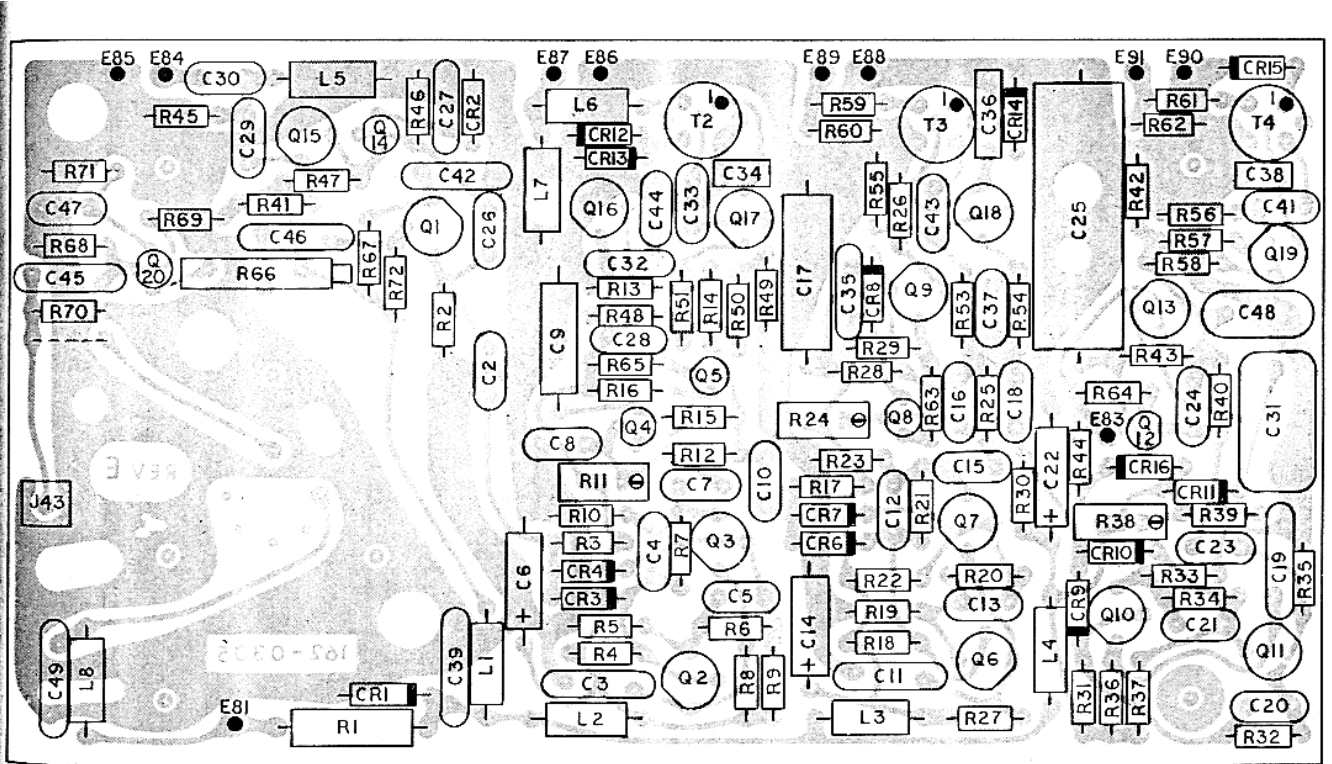

Figure 8.3 – Divider/Spectrum Generator Parts Location

Figure 8.4 Divider/Spectrum Generator Schematic Diagram.

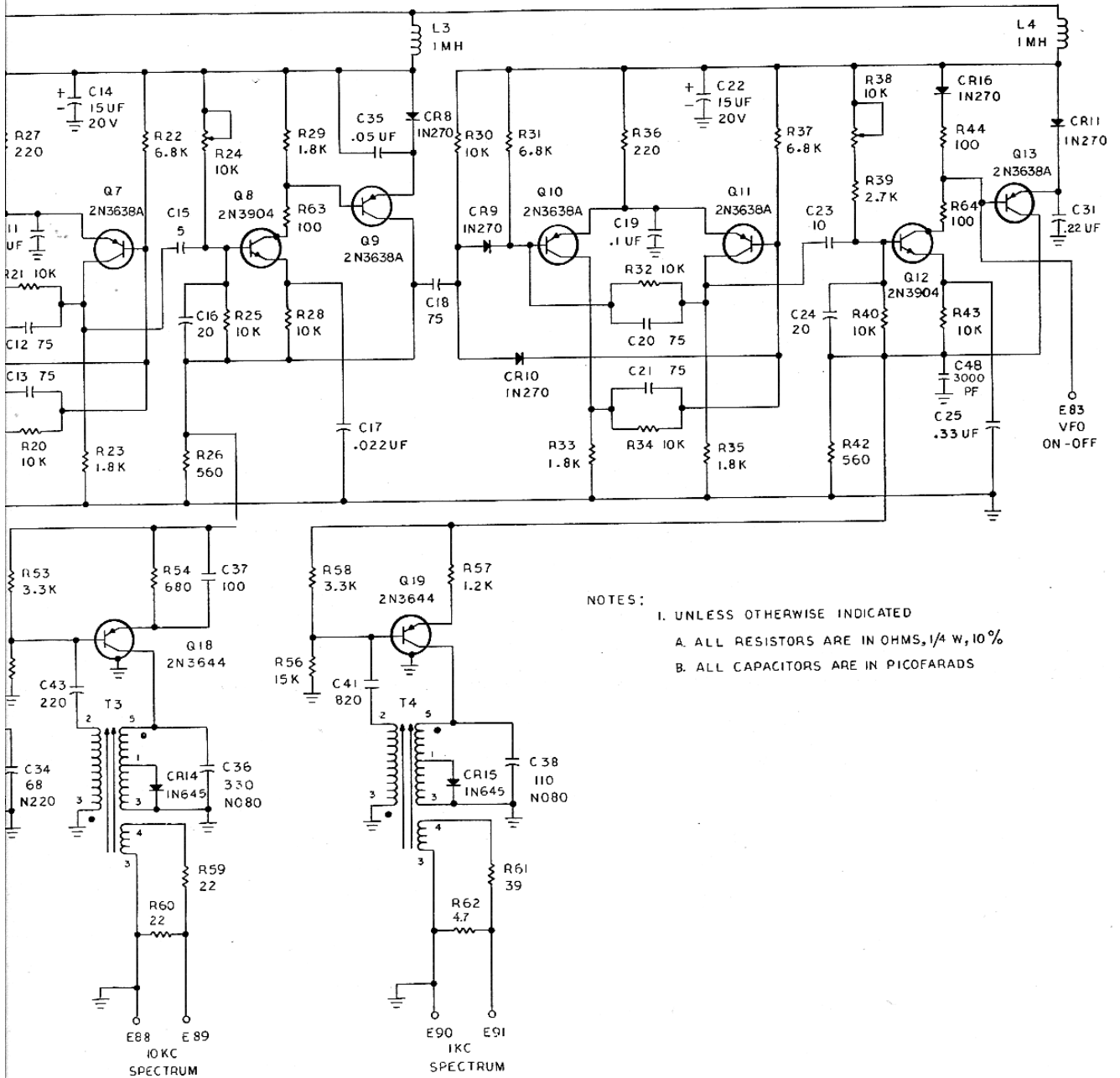

Figure 8.4 – Divider/Spectrum Generator Schematic Diagram

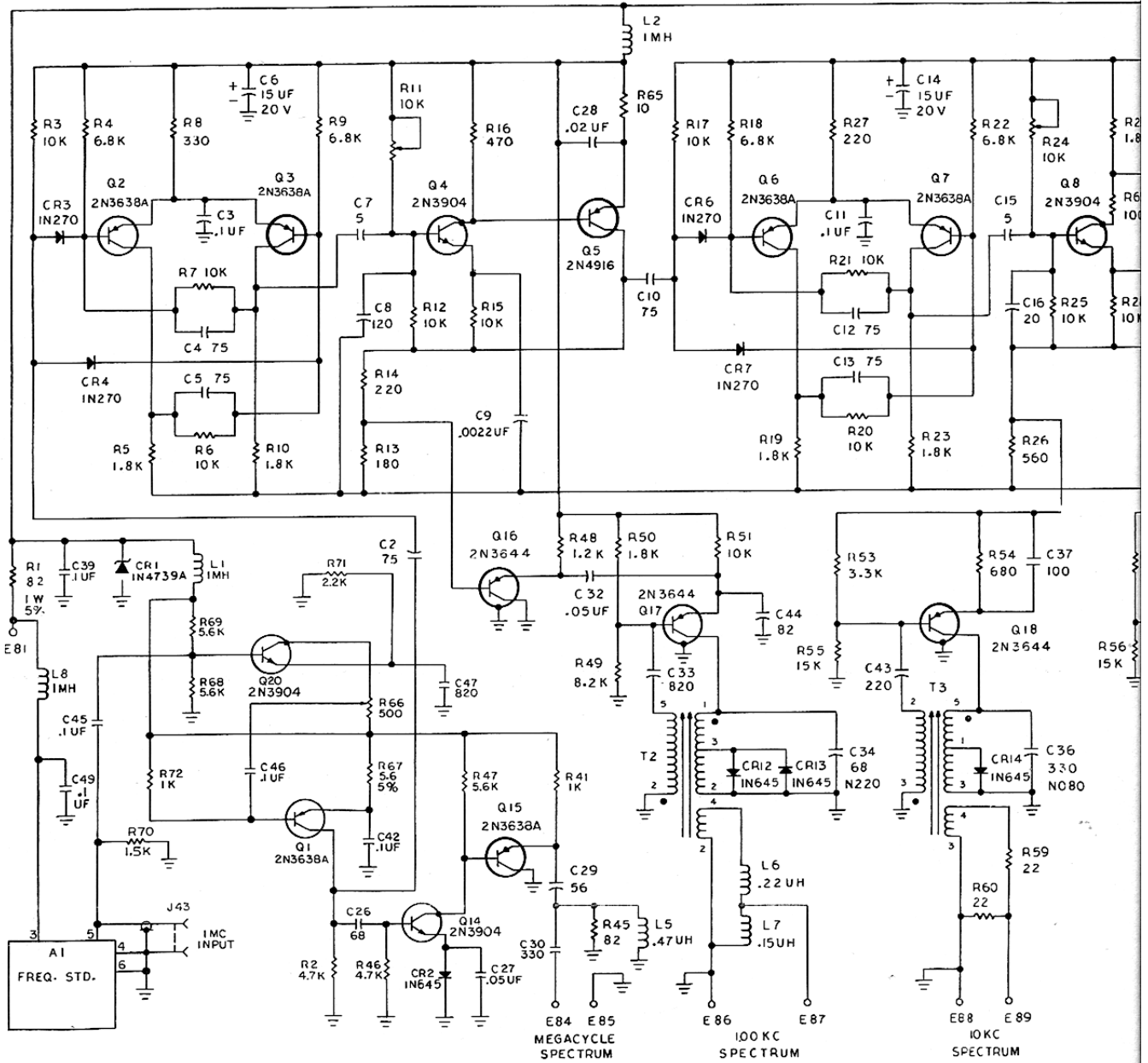

Figure 8.5 11,6 Mhz Error Mixer Parts Location.

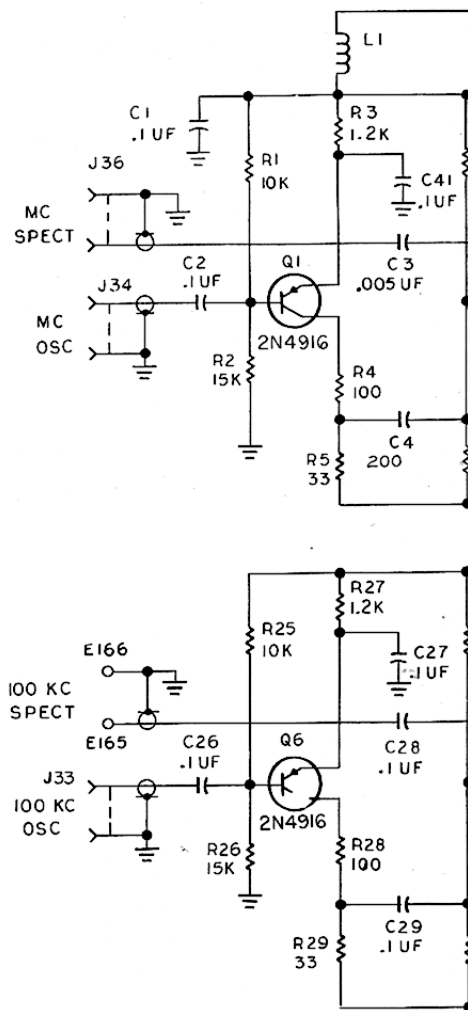
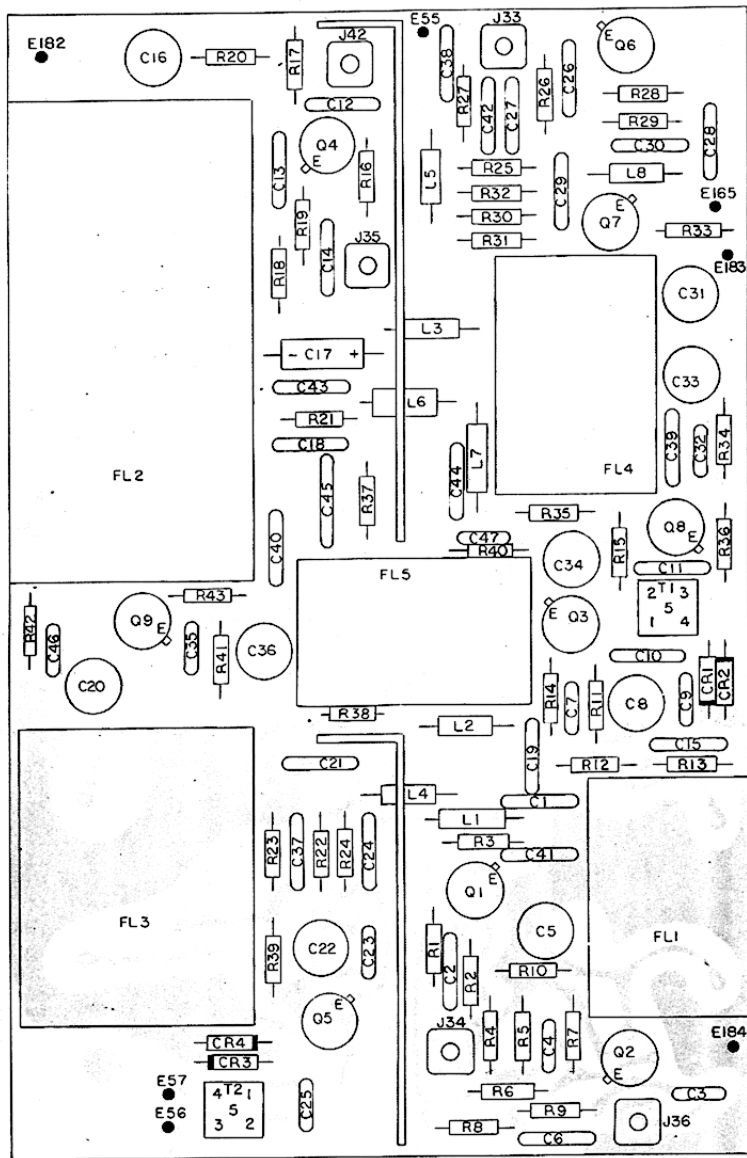
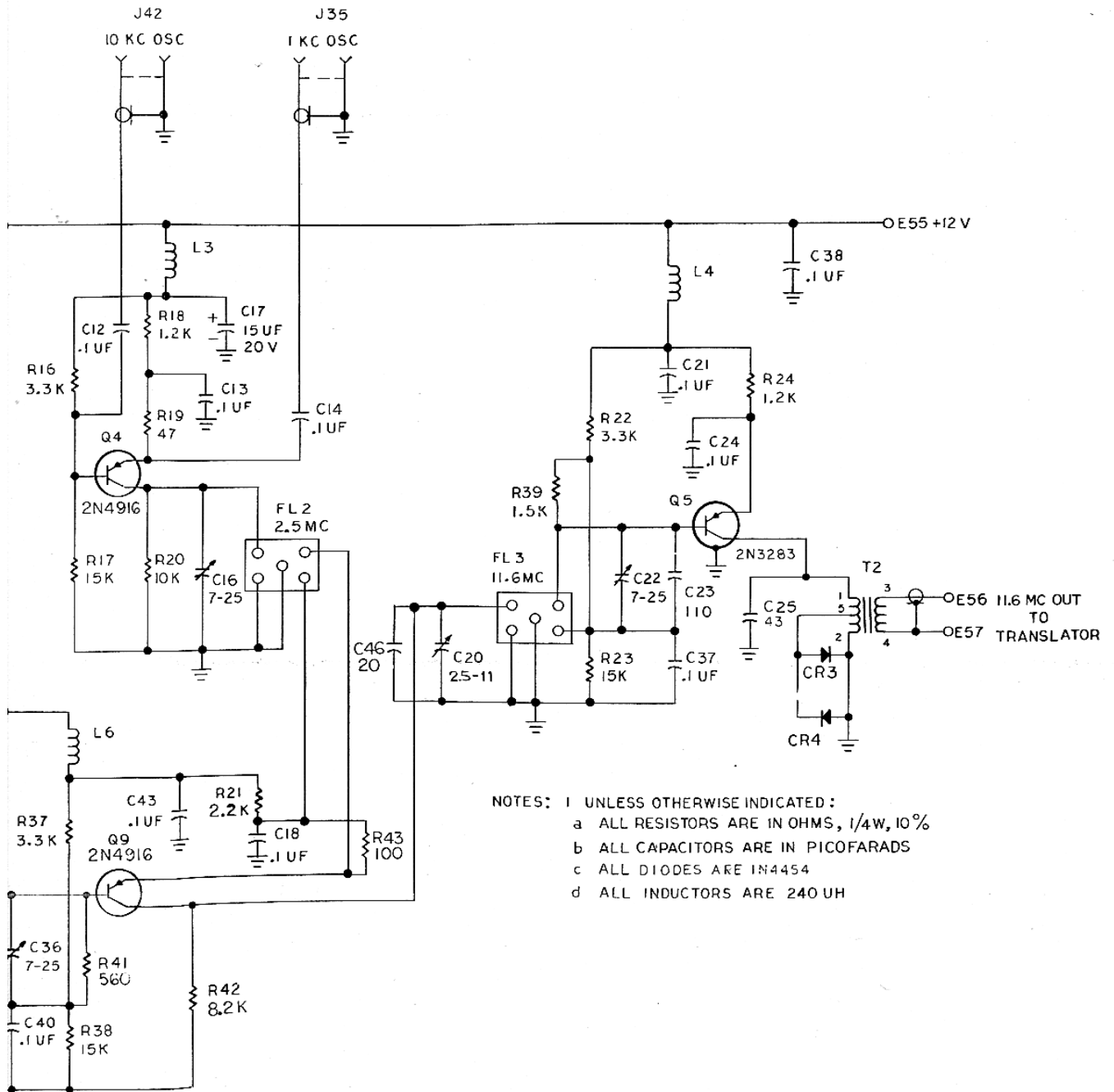

Figure 8.5 – 11.6 MHz Error Mixer Parts Location

Figure 8.6 11,6 Mhz Error Mixer Schematic Diagram.



- NOTES: I UNLESS OTHERWISE INDICATED:
- a ALL RESISTORS ARE IN OHMS, 1/4W, 10%
 - b ALL CAPACITORS ARE IN PICOFARADS
 - c ALL DIODES ARE IN4454
 - d ALL INDUCTORS ARE 240 UH

Figure 8.6 — 11.6 MHz Error Mixer Schematic Diagram

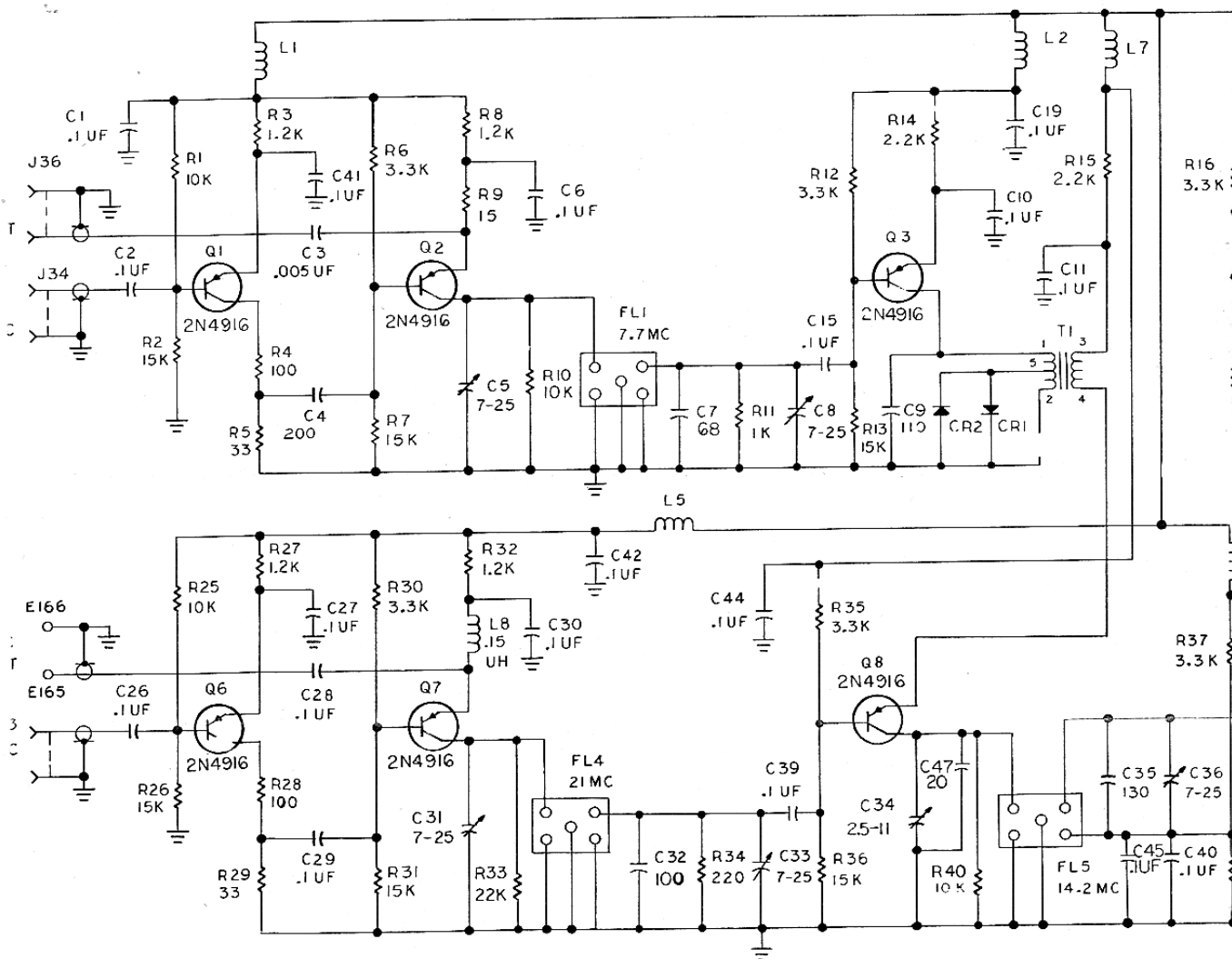
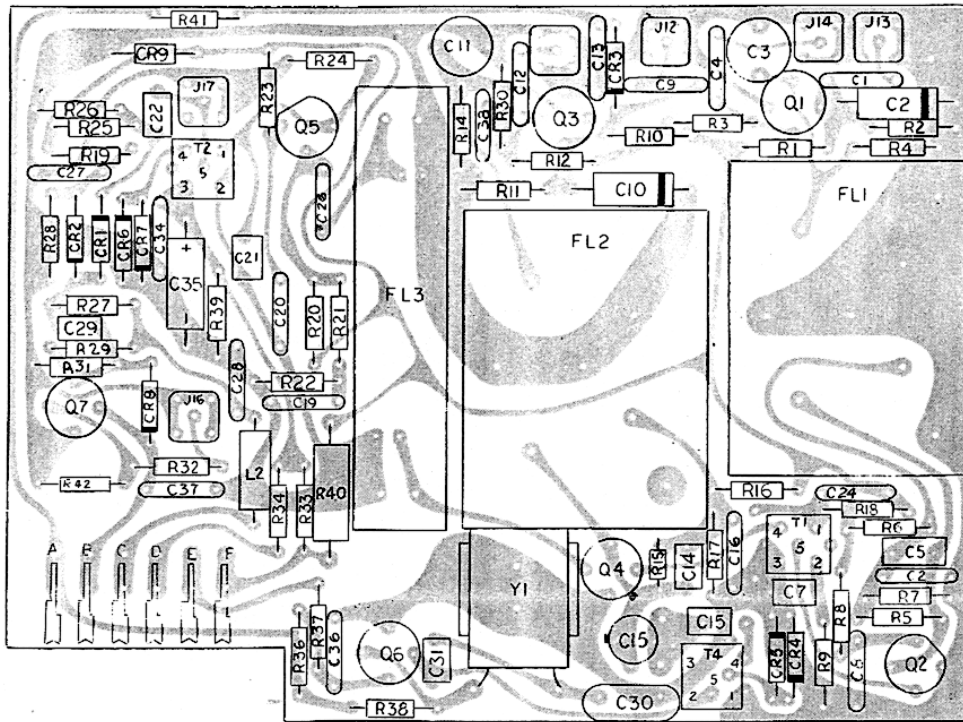

Figure 8.7 455 Khz Error Mixer Parts Location.



CR9
IN4739F

Figure 8.7 – 455 kHz Error Mixer Parts Location

Figure 8.8 455 KHz Error Mixer Schematic Diagram.

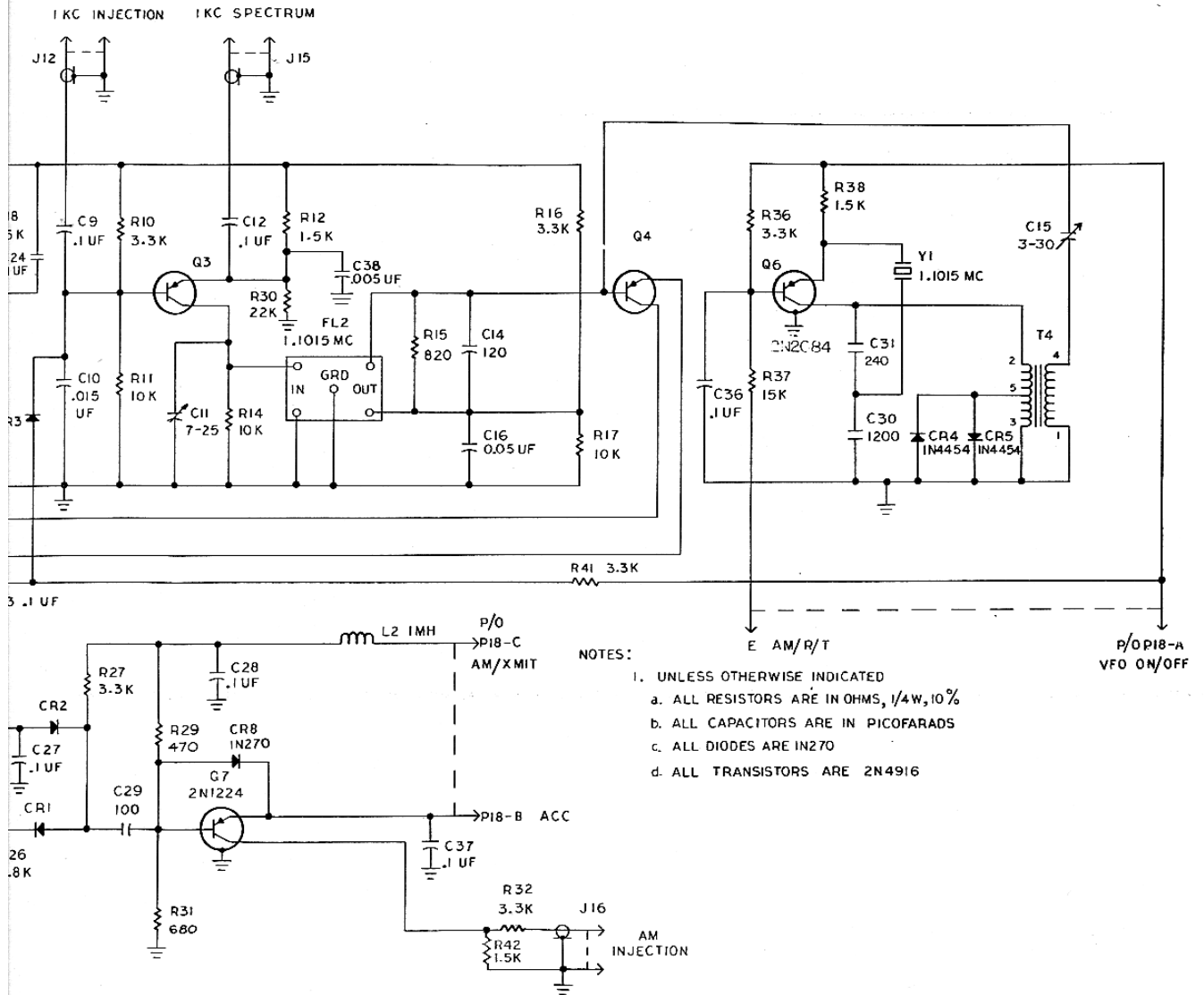

Figure 8.8 – 455 kHz Error Mixer Schematic Diagram

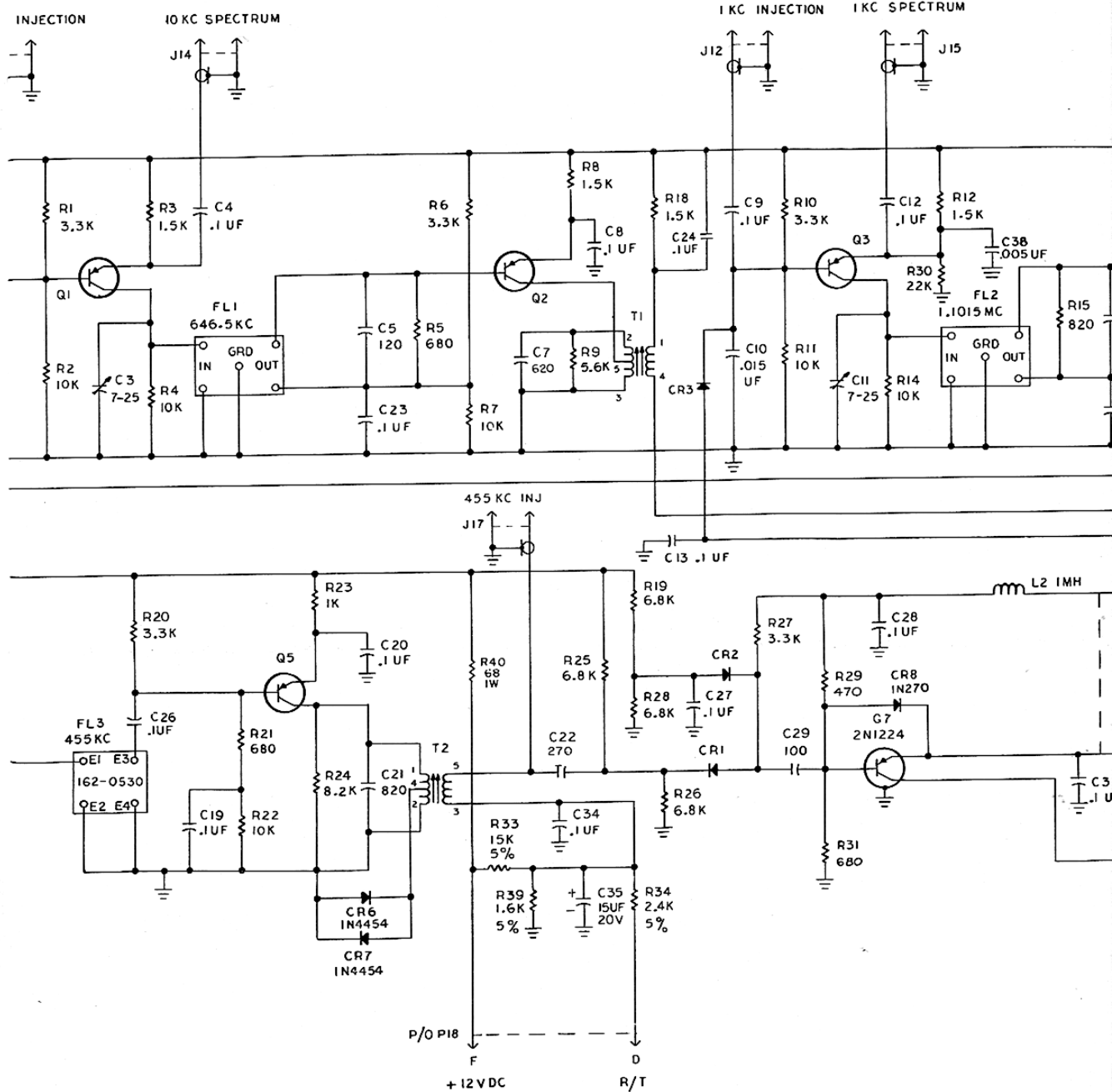

Figure 8.9 Translator Parts Location.

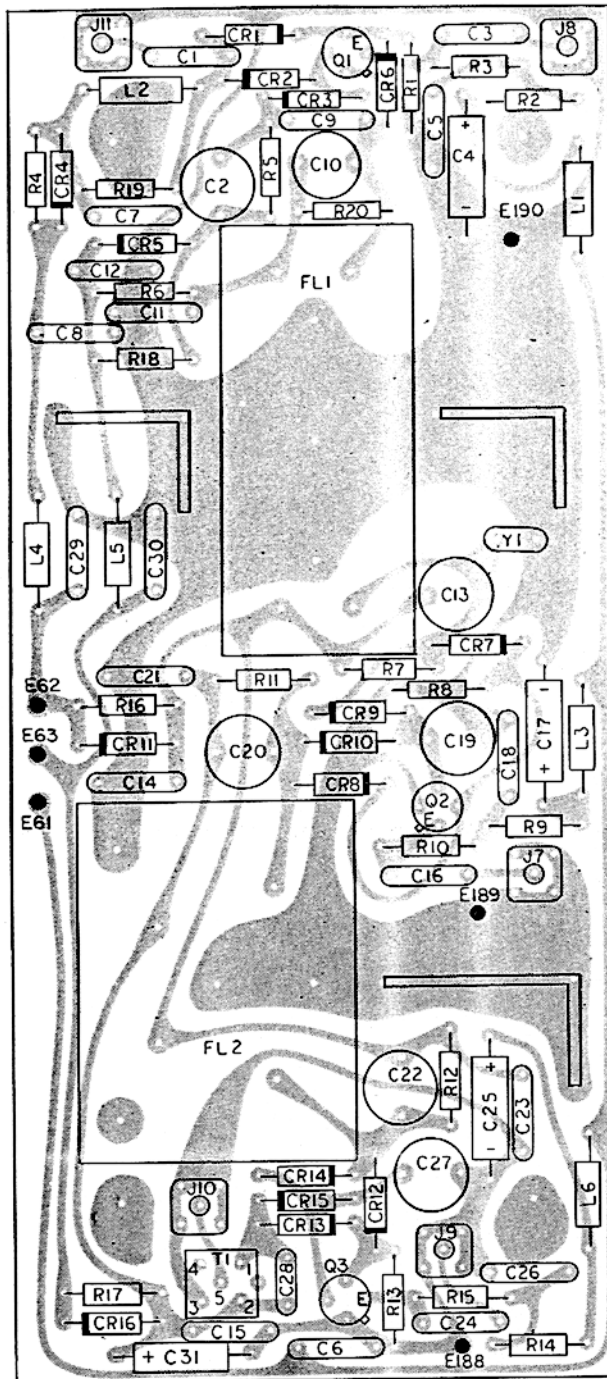
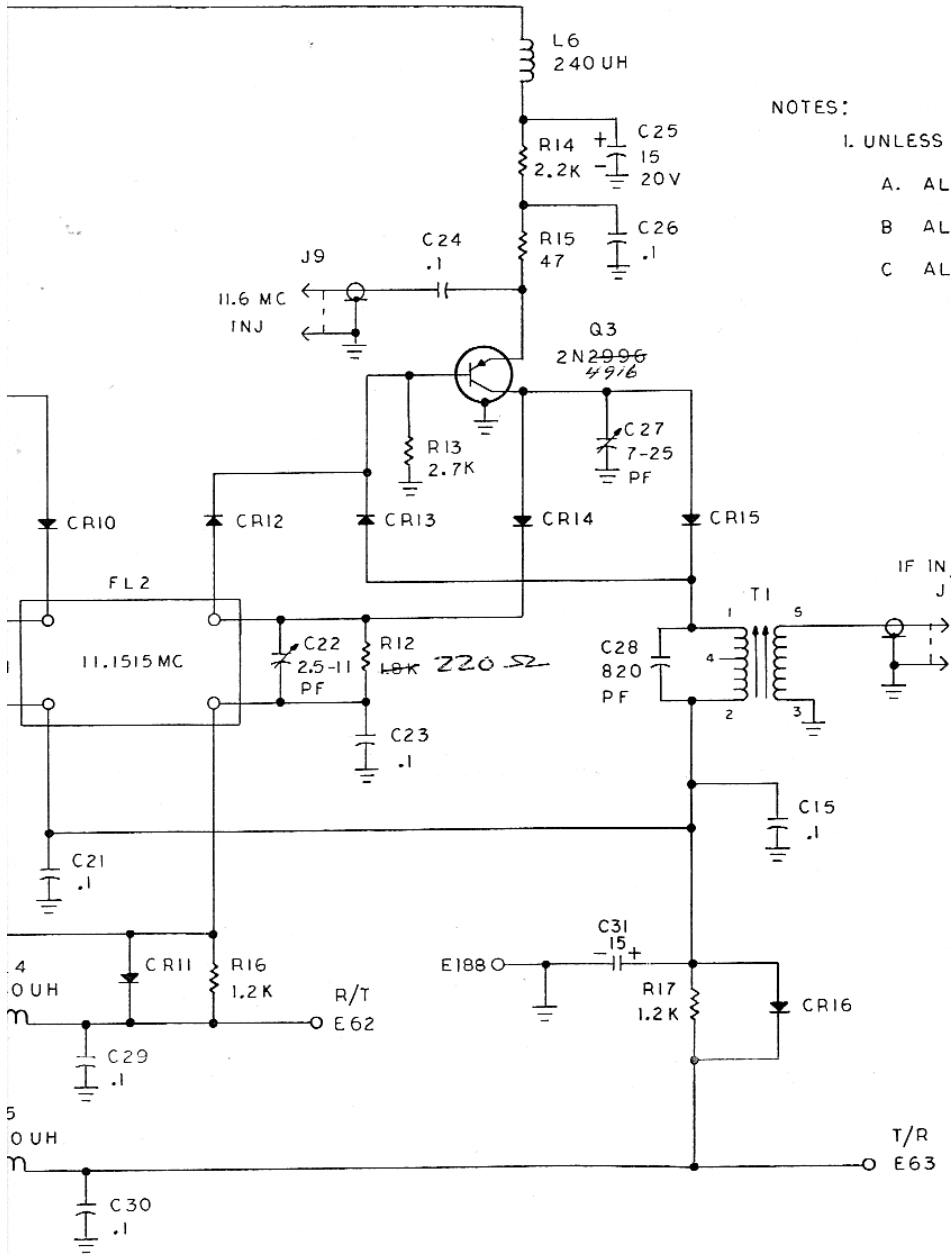

Figure 8.9 – Translator Parts Location

Figure 8.10 Translator Schematic Diagram.



NOTES:

I. UNLESS OTHERWISE INDICATED

- A. ALL RESISTORS ARE IN OHMS, 1/4 W, 10%
- B. ALL DIODES ARE 1N270
- C. ALL CAPACITORS ARE IN MICROFARADS

Figure 8.10 — Translator Schematic Diagram

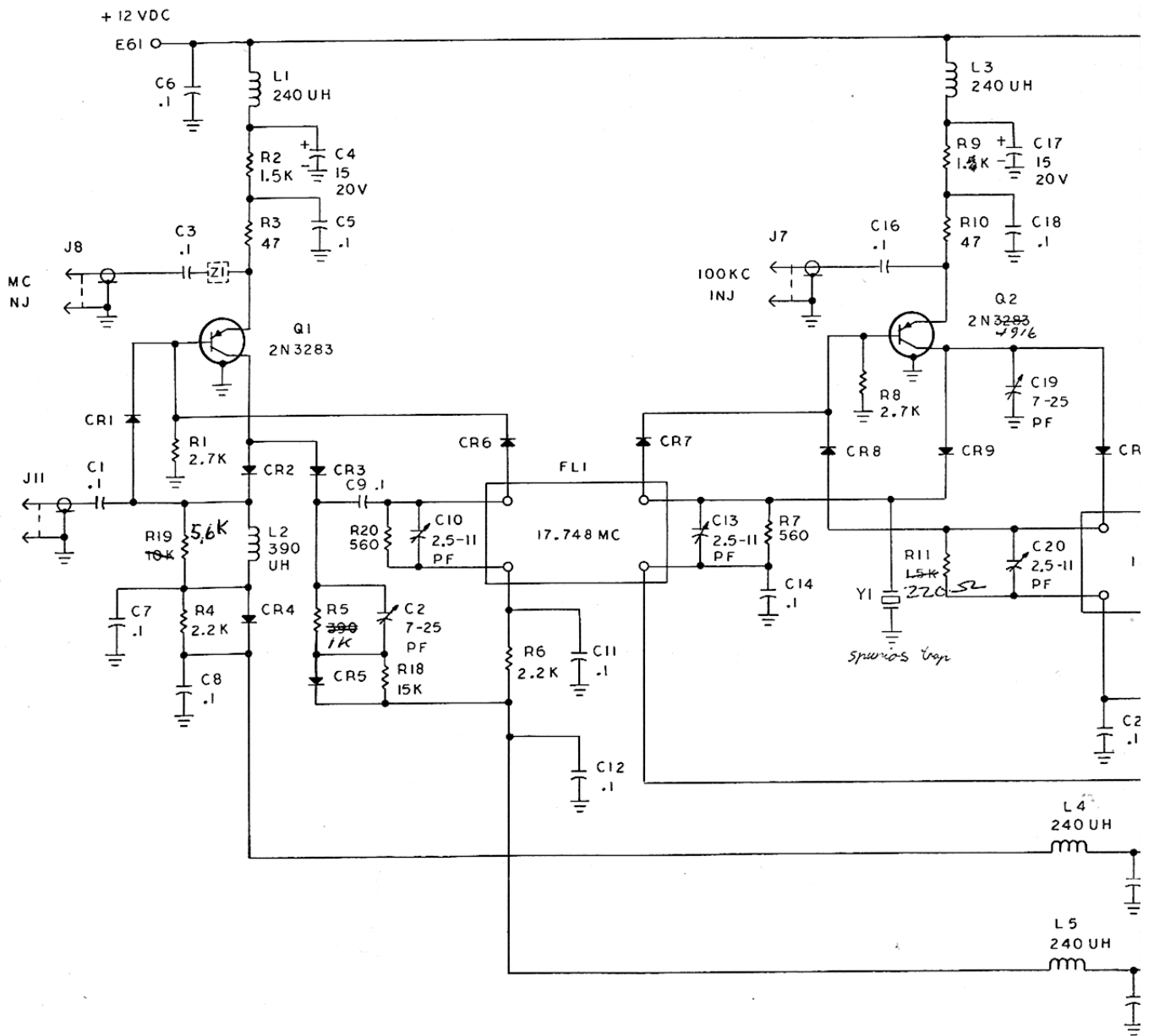

Figure 8.11 IF Amplifier Parts Location.

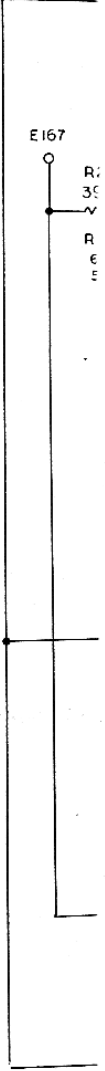
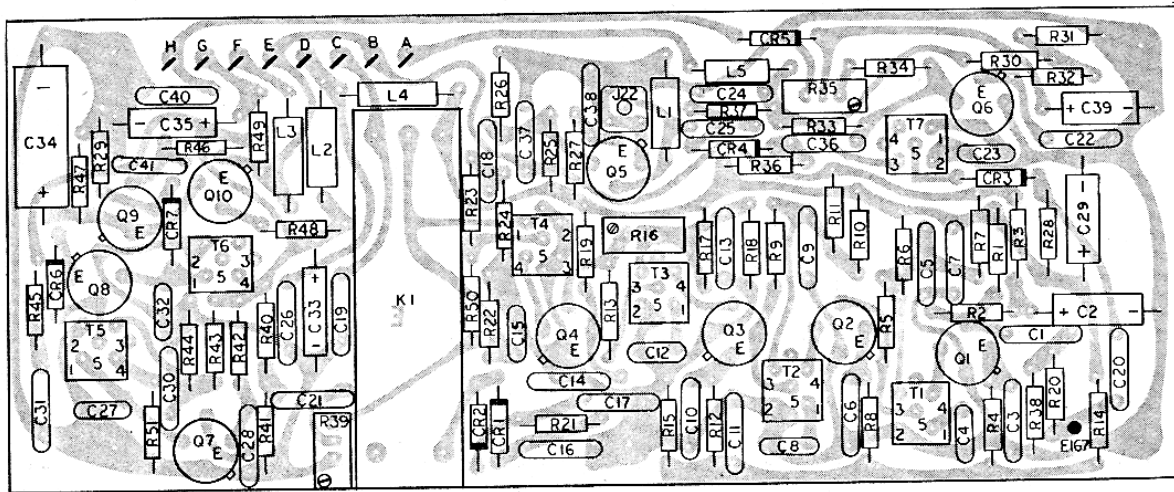
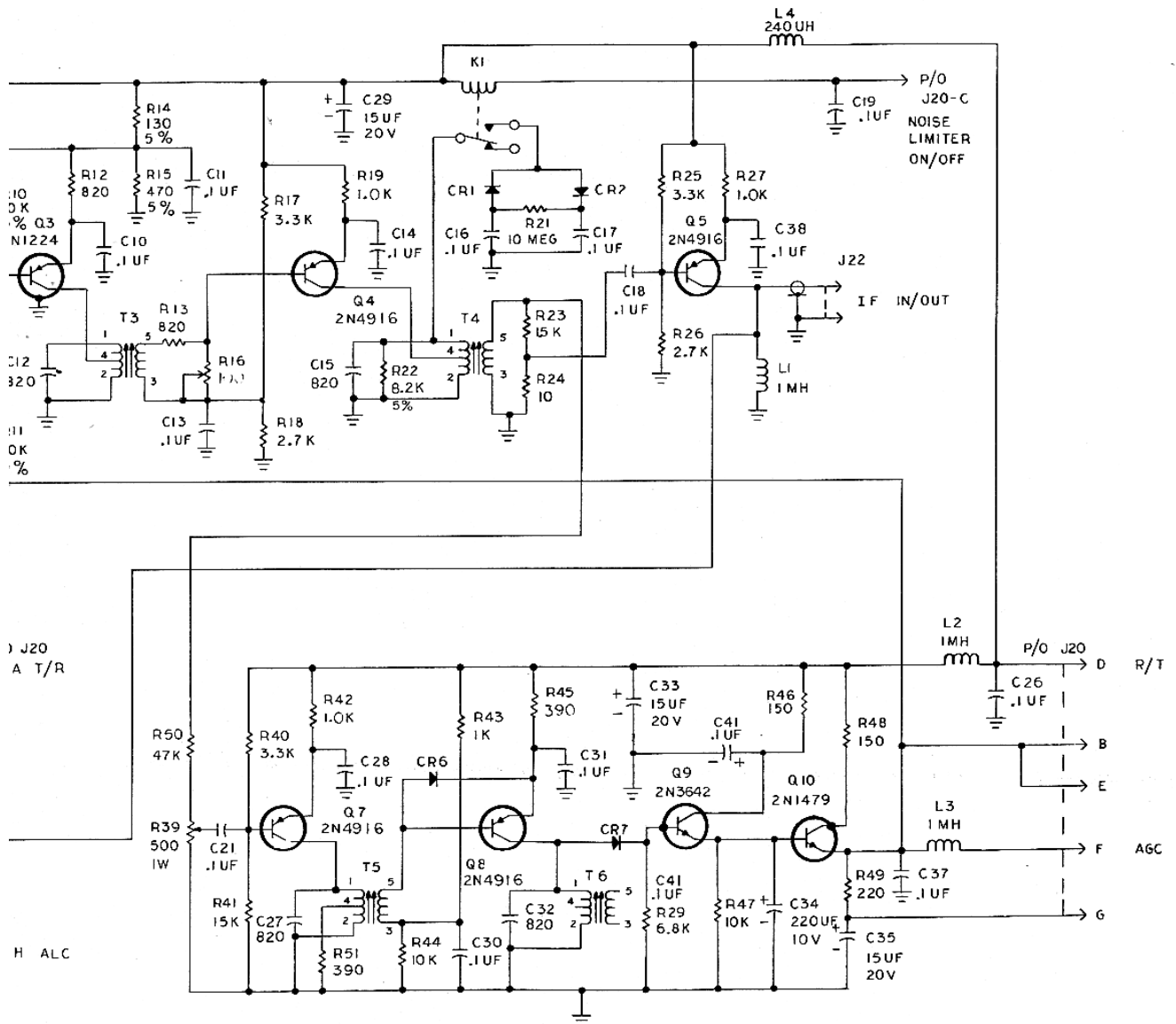

Figure 8.11 – IF Amplifier Parts Location

Figure 8.12 IF Amplifier Parts Location.



- NOTES:
- I. UNLESS OTHERWISE INDICATED
 - a. RESISTORS ARE IN OHMS, 1/4W, 10%
 - b. CAPACITORS ARE IN PICOFARADS
 - c. DIODES ARE IN270

Figure 8.12 – IF Amplifier Schematic Diagram

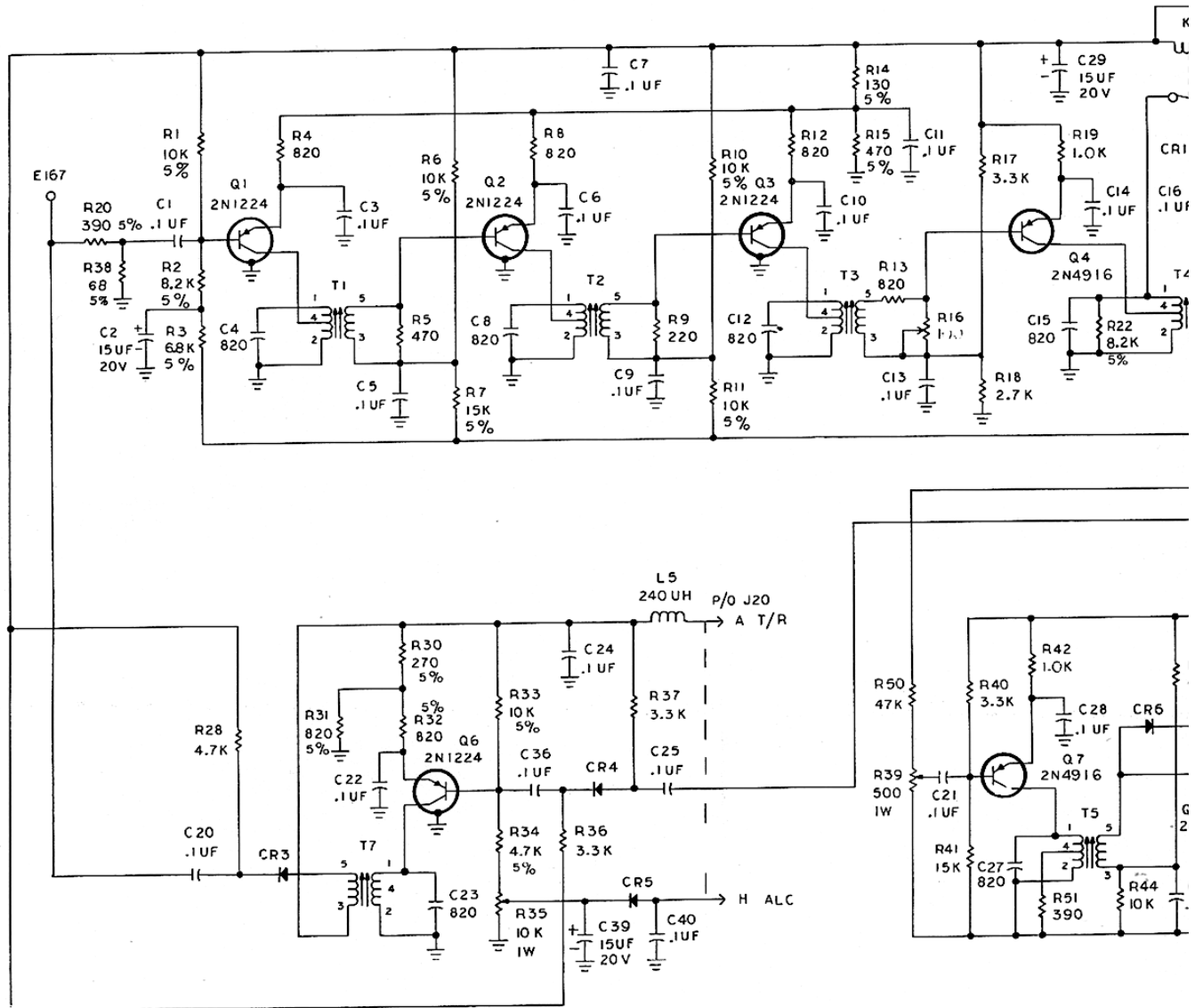

NOTES:

- I. UNLESS OTHERWISE INDICATED
- a. RESISTORS ARE IN OHMS
- b. CAPACITORS ARE IN MICROFARADS
- c. DIODES ARE IN 2N70

8.13 Audio/Modulator Parts Location.

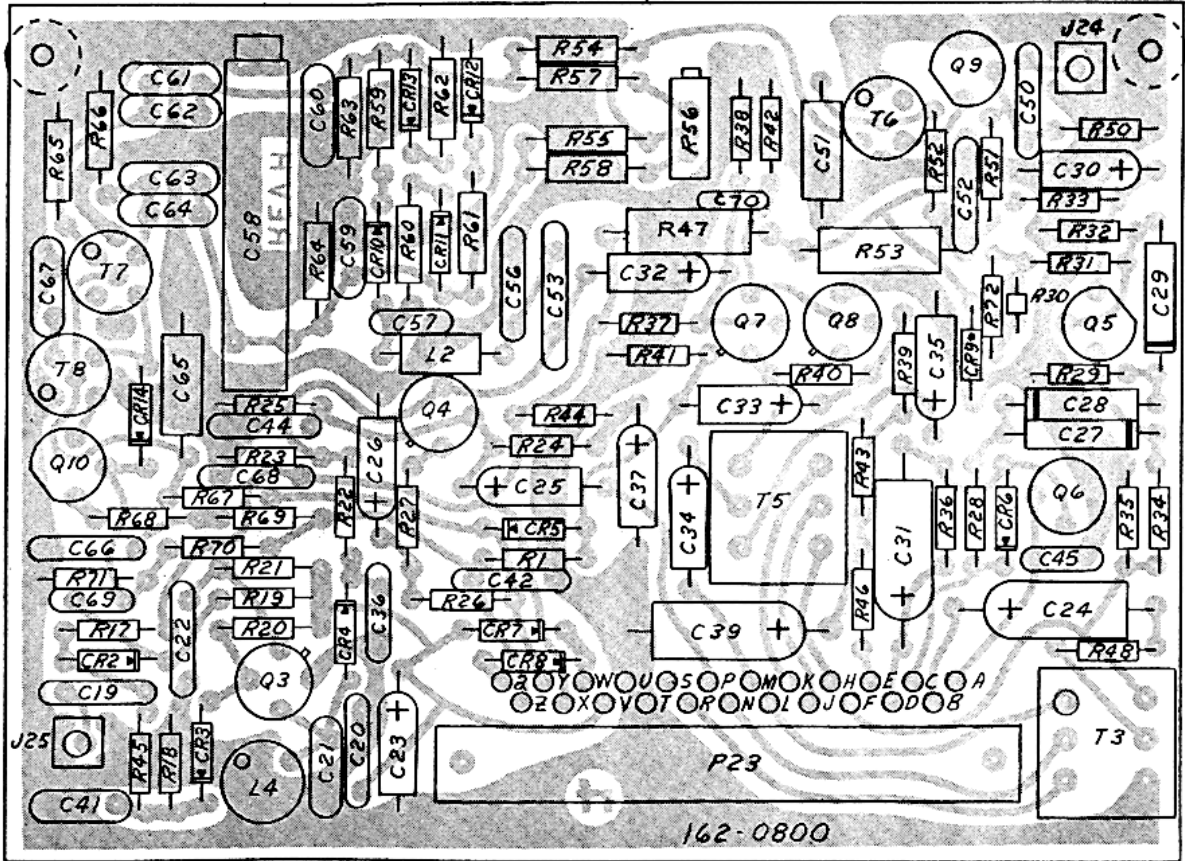

Figure 8.13 – Audio/Modulator Parts Location

Figure 8.14 Audio/Modulator Schematic Diagram.

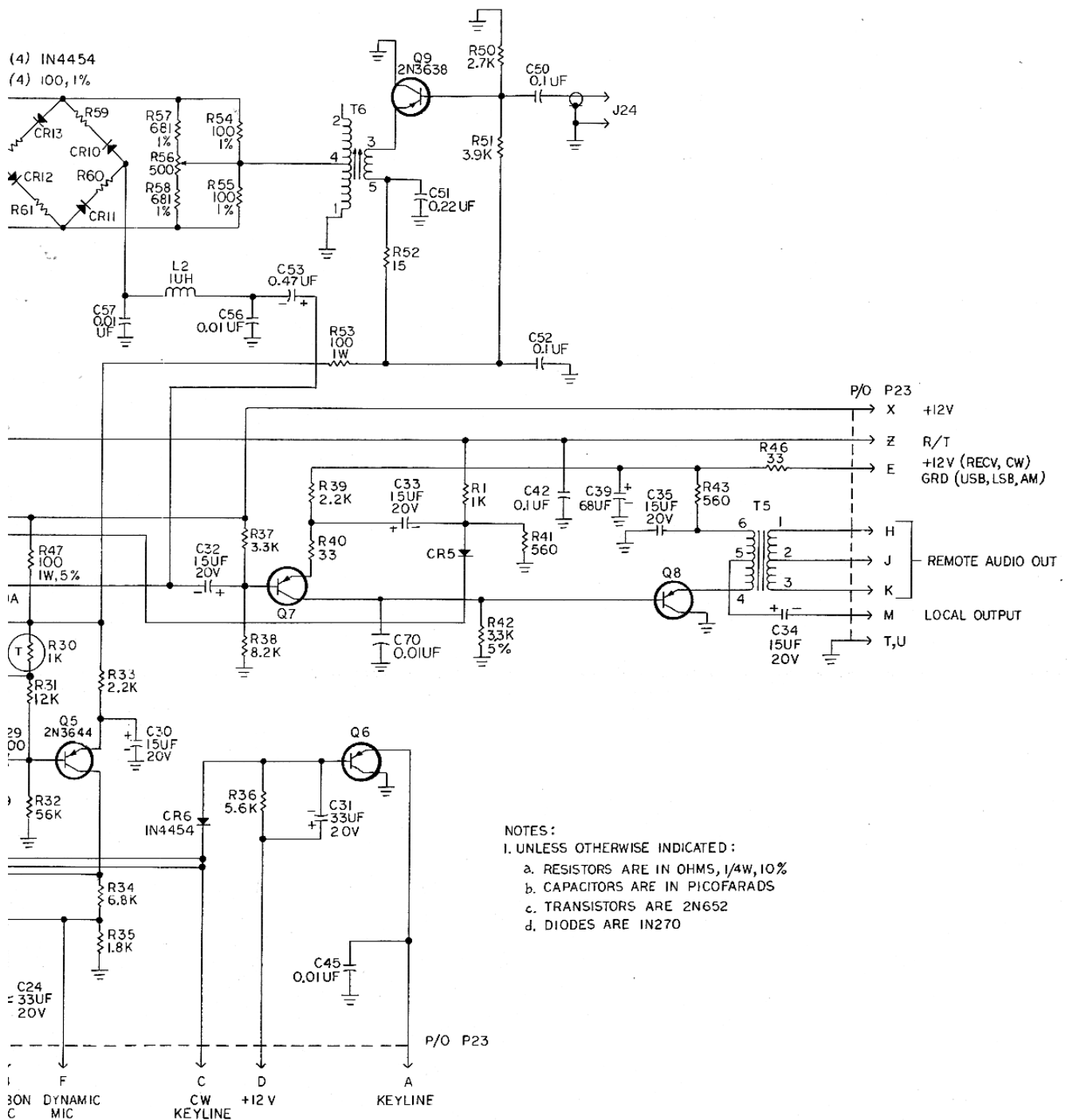
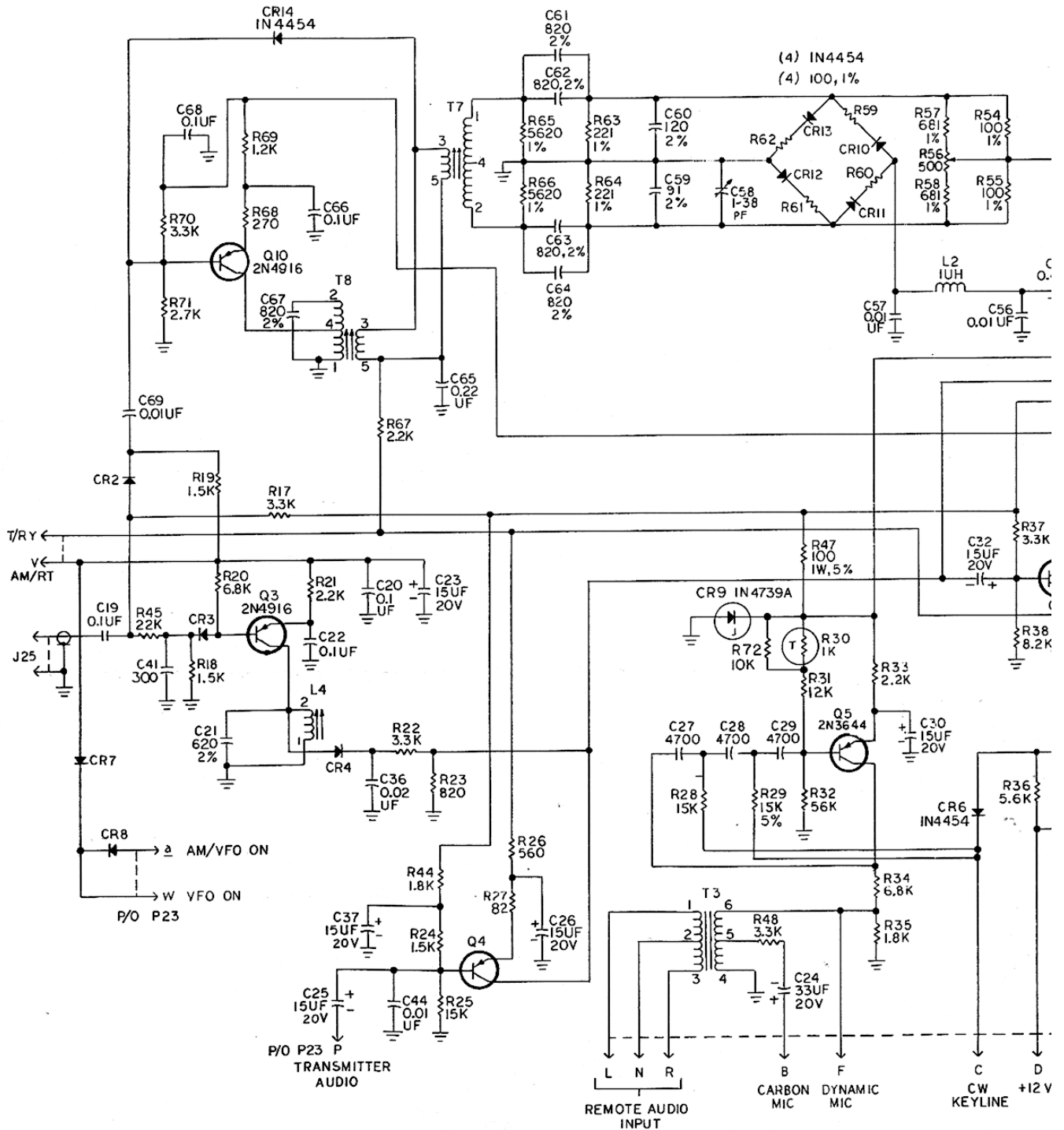
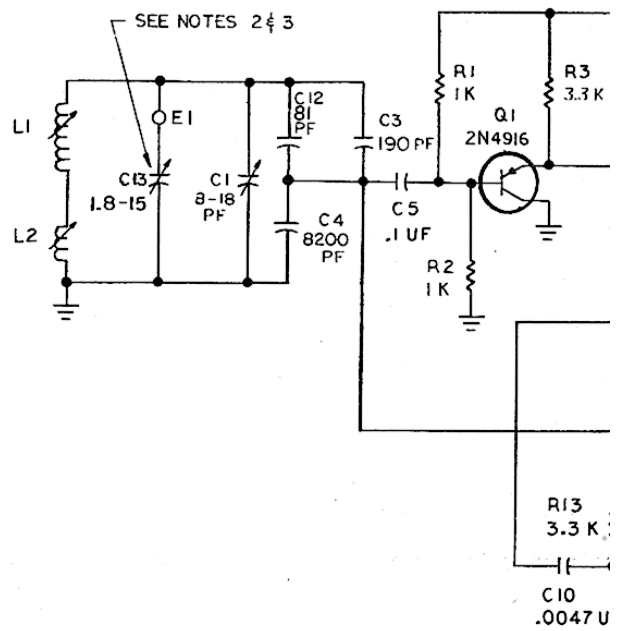
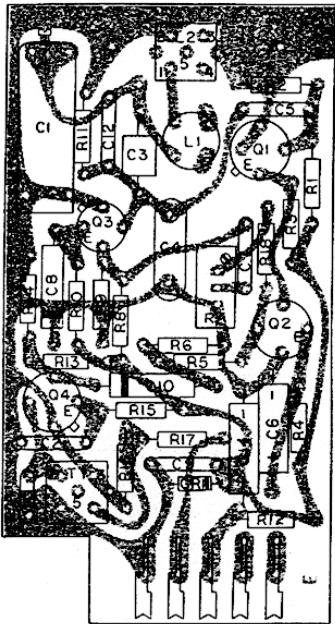

Figure 8.14 – Audio/Modulator Schematic Diagram



8.15 VFO Parts Location & 8.16 VFO Schematic Diagram.



- NOTES:
1. RES ARE IN OHMS, 1/4 W, 10%
 2. ON RF 301, 301A & 301E
C13 IS LOCATED ON VFO BRKT
 3. ON RF 301P
C13 IS LOCATED ON 591-1300 ASSY

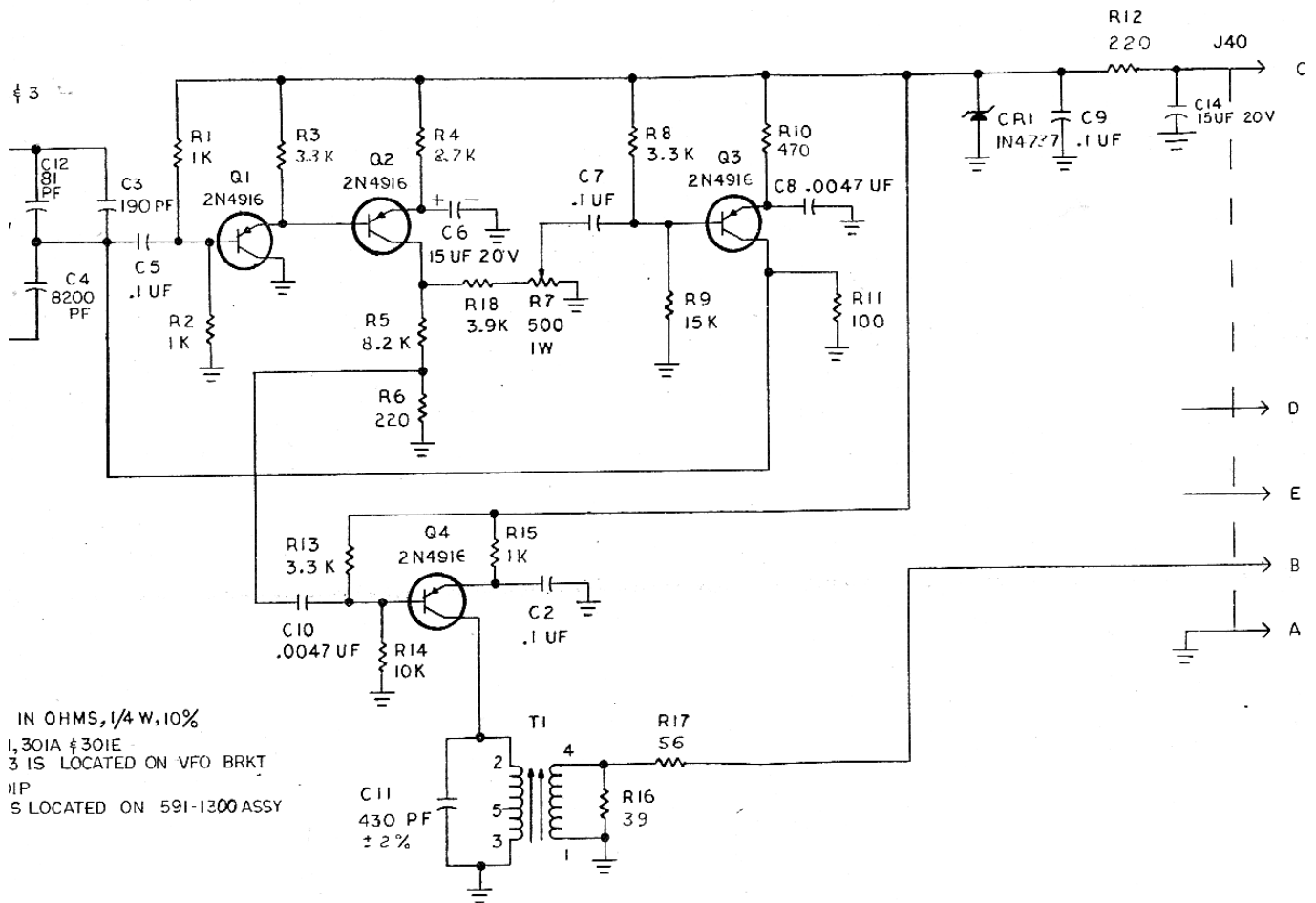
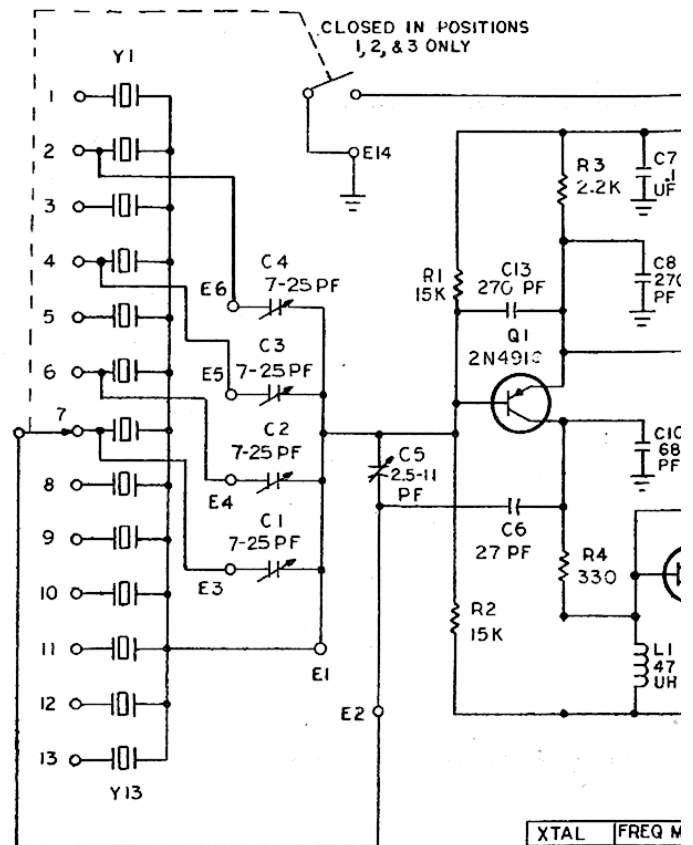
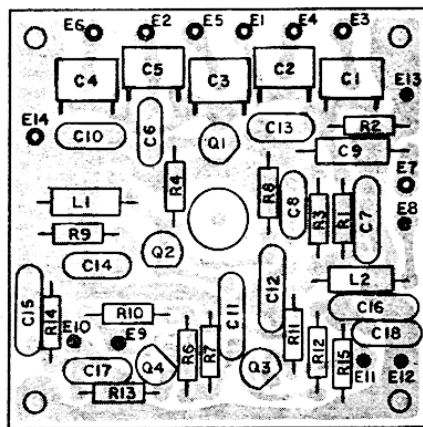

Figure 8.16 – VFO Schematic Diagram

8.17 MHZ Oscillator Parts Location & 8.18 Mhz Oscillator Schematic Diagram.



XTAL	FREQ M
Y1	3.24
Y2	4.24
Y3	5.24
Y4	6.24
Y5	7.24
Y6	8.24
Y7	9.24
Y8	10.24
Y9	11.24
Y10	12.24
Y11	13.24
Y12	14.24
Y13	15.24

Figure 8.17 – MHz Oscillator Parts Location

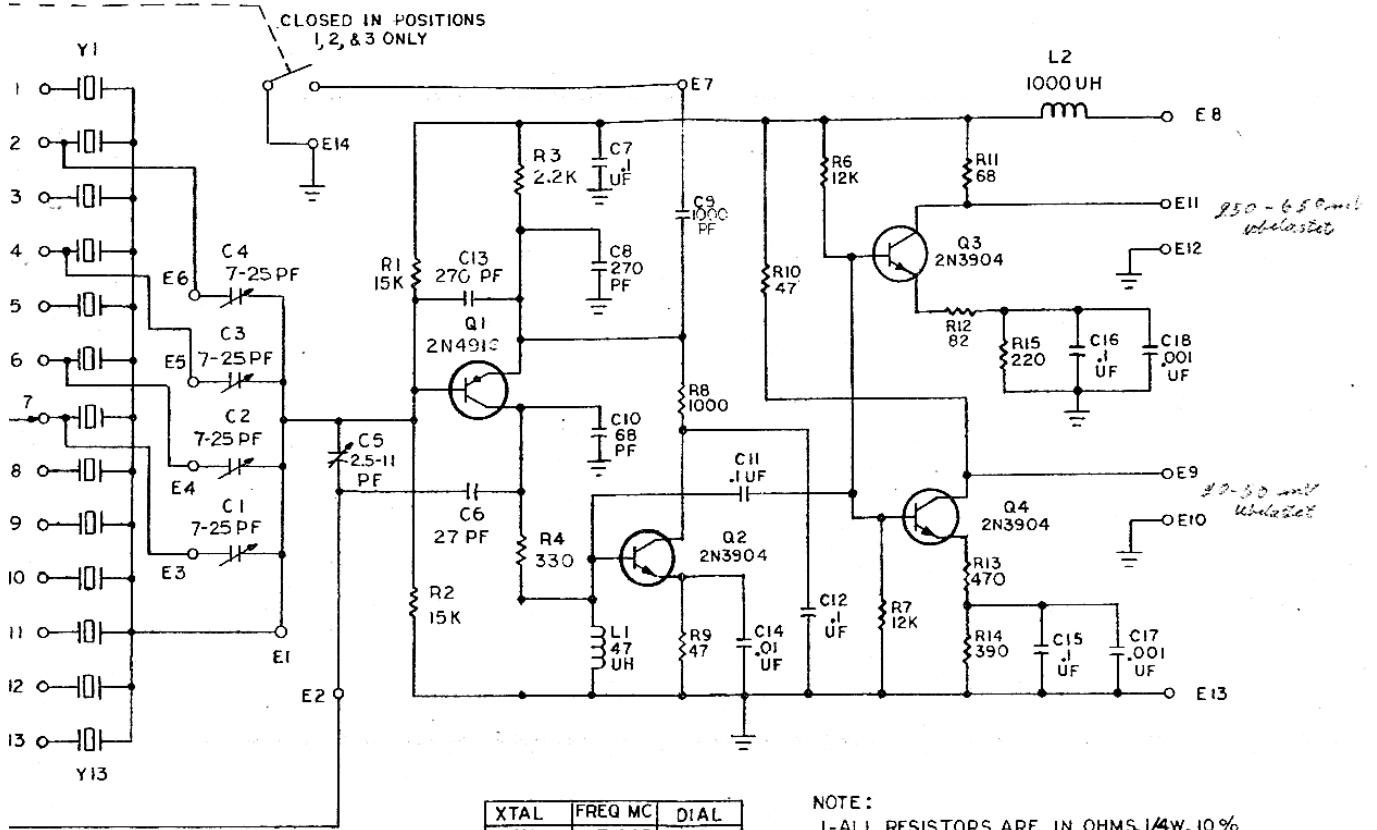

XTAL	FREQ MC	DIAL
Y1	3.247	14
Y2	4.247	13
Y3	5.247	12
Y4	6.247	11
Y5	7.247	10
Y6	8.247	9
Y7	9.247	8
Y8	10.247	7
Y9	11.247	6
Y10	12.247	5
Y11	13.247	4
Y12	14.247	3
Y13	15.247	2

NOTE:
1-ALL RESISTORS ARE IN OHMS, 1/4W, 10%

Figure 8.18 - MHz Oscillator Schematic Diagram

8.19 100 Khz Oscillator Parts Location & 8.20 100 Khz Oscillator Schematic Diagram.

ASSEMBLY		
C1	Capacitor, mylar, .0015 uF, 100 VDCW	C-2102
C2	Capacitor, mylar, .01 uF, 100 VDCW	C-2112
C5, C6	Same as C1	C-2102
C7, C8	Capacitor, ceramic, .1 uF, 25 VDCW	C-2210
L1, L2	Inductor, 4.7 uH	L-0056
L3	Inductor, 240 uH	L-0052
Q1	Transistor, type 2N4916	Q-0360
Q2	Transistor, type 2N4124	Q-0385
R1	Resistor, composition, 2.7K, 1/2W, 5%	R-1459
R2	Resistor, composition, 680 ohms, 1/2W, 5%	R-1445
R3	Resistor, composition, 39 ohms, 1/2W, 10%	R-0107
R4	Resistor, composition, 22K, 1/2W, 5%	R-1481
R5	Resistor, composition, 2.2K, 1/2W, 5%	R-1457
R6	Resistor, composition, 5.6K, 1/2W, 10%	R-0133
R7	Resistor, composition, 390 ohms, 1/2W, 10%	R-0119
R8	Resistor, composition, 820 ohms, 1/2W, 10%	R-0123
R9	Resistor, composition, 10 ohms, 1/2W, 10%	R-0100

S1	Switch	162-1203
Y1	Crystal, 1.7565 MHz	Y-0600
Y2	Crystal, 1.7665 MHz	Y-0601
Y3	Crystal, 1.7765 MHz	Y-0602
Y4	Crystal, 1.7865 MHz	Y-0603
Y5	Crystal, 1.7965 MHz	Y-0604
Y6	Crystal, 1.8065 MHz	Y-0605
Y7	Crystal, 1.8165 MHz	Y-0606
Y8	Crystal, 1.8265 MHz	Y-0607
Y9	Crystal, 1.8365 MHz	Y-0608
Y10	Crystal, 1.8465 MHz	Y-0609



*PARTS LIST HERE TO TIL PA^o NÆSTE SIDE
100KHZ OSC.*

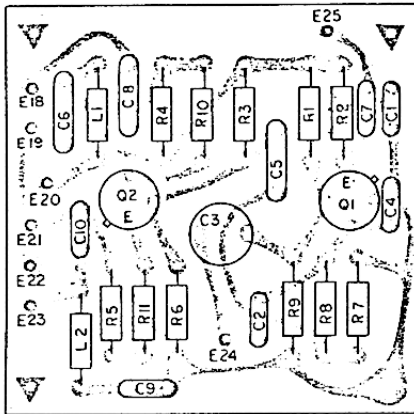
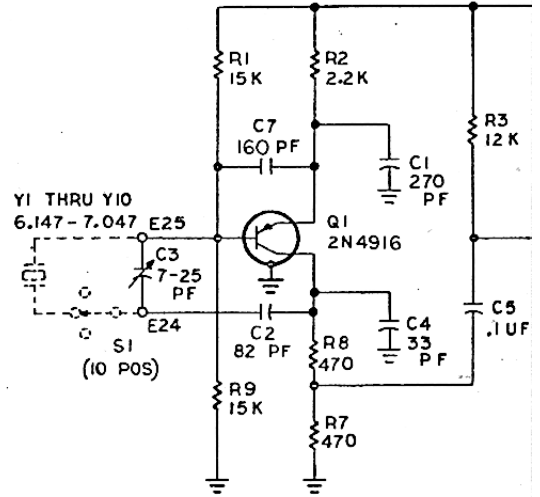

FIG 8.19
100KHZ OSC. PARTS LOCATION



NOTES: 1. ALL RESISTORS ARE IN OHMS,

FIG 8.20

100KHZ

8-21/8-22



- 162-1203
- Y-0600
- Y-0601
- Y-0602
- Y-0603
- Y-0604
- Y-0605
- Y-0606
- Y-0607
- Y-0608
- Y-0609

718E

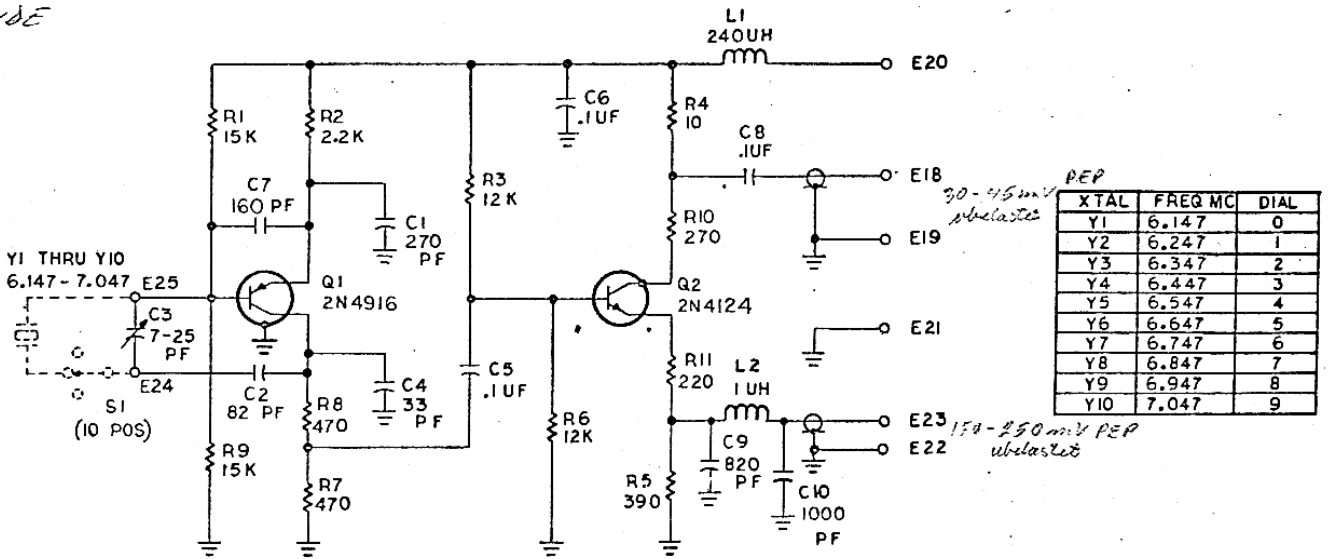

NOTES: 1. ALL RESISTORS ARE IN OHMS, 1/2W, 10%

FIG 8.20

100kHz OSC. SCHEMATIC DIAGRAM

8.21 10 Khz Oscillator Parts Location & 8.22 10 Khz Oscillator Schematic Diagram.

C1	Capacitor, dipped-mica, 270 pF, 500 VDCW, 5%	C-0137
C2	Capacitor, dipped-mica, 82 pF, 500 VDCW, 5%	C-0124
C3	Capacitor, variable, 7-25 pF	C-2304
C4	Capacitor, dipped-mica, 33 pF, 500 VDCW, 5%	C-0113
C5, C6	Capacitor, ceramic, .1 uF, 25 VDCW	C-2210
C7	Capacitor, dipped-mica, 160 pF, 500 VDCW, 5%	C-0131
C8	Same as C5	C-2210
C9	Capacitor, dipped-mica, 820 pF, 300 VDCW, 2%	C-2503
C10	Capacitor, dipped-mica, 1000 pF, 300 VDCW, 2%	C-2505
L1	Inductor, 240 uH	L-0052
L2	Inductor, 1 uH	L-0054
Q1	Transistor, type 2N4916	Q-0360
Q2	Transistor, type 2N4124	Q-0385
R1	Resistor, composition, 15K, 1/2W, 10%	R-0138
R2	Resistor, composition, 2.2K, 1/2W, 10%	R-0128
R3	Resistor, composition, 12K, 1/2W, 10%	R-0137
R4	Resistor, composition, 10 ohms, 1/2W, 10%	R-0100
R5	Resistor, composition, 390 ohms, 1/2W, 10%	R-0119
R6	Same as R3	R-0137
R7, R8	Resistor, composition, 470 ohms, 1/2W, 10%	R-0120
R9	Same as R1	R-0138
R10	Resistor, composition, 270 ohms, 1/2W, 10%	R-0117

REF DESIG	DESCRIPTION	RF P.
R11	Resistor, composition, 220 ohms, 1/2W, 10%	R-0116
S1	Switch	162-11
Y1	Crystal, 6.147 MHz	Y-0453
Y2	Crystal, 6.247 MHz	Y-0454
Y3	Crystal, 6.347 MHz	Y-0455
Y4	Crystal, 6.447 MHz	Y-0456
Y5	Crystal, 6.547 MHz	Y-0457
Y6	Crystal, 6.647 MHz	Y-0458
Y7	Crystal, 6.747 MHz	Y-0459
Y8	Crystal, 6.847 MHz	Y-0460
Y9	Crystal, 6.947 MHz	Y-0461
Y10	Crystal, 7.047 MHz	Y-0462

*PARTS LIST HØRER TIL
PÅ ~~THE~~ FORRIGE SIDE
100 KHZ OSC.*

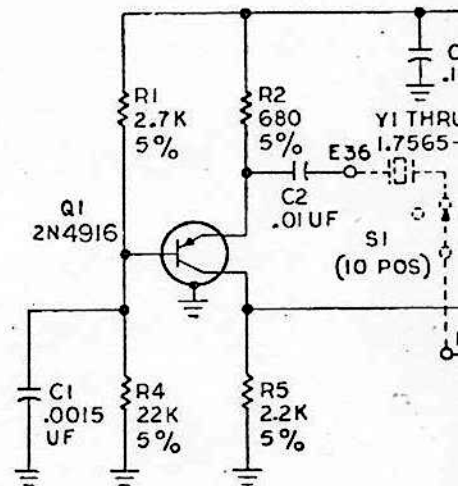
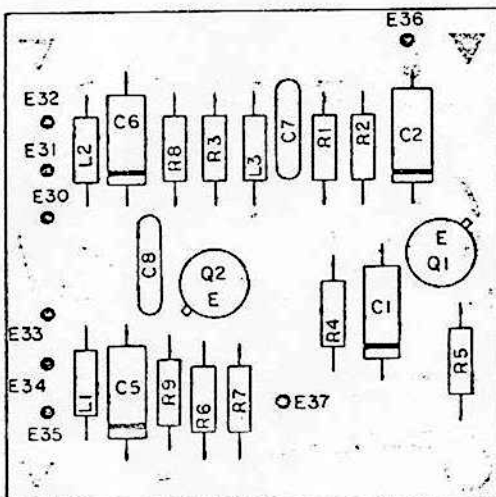

NOTES:

1. ALL RESISTORS ARE IN OHM

Figure 8.21 – 10 kHz Oscillator Parts Location



REF DESIG	DESCRIPTION	RF P/N
11	Resistor, composition, 220 ohms, 1/2W, 10%	R-0116
	Switch	162-1103
1	Crystal, 6.147 MHz	Y-0453
2	Crystal, 6.247 MHz	Y-0454
3	Crystal, 6.347 MHz	Y-0456
4	Crystal, 6.447 MHz	Y-0457
5	Crystal, 6.547 MHz	Y-0458
6	Crystal, 6.647 MHz	Y-0459
7	Crystal, 6.747 MHz	Y-0460
8	Crystal, 6.847 MHz	Y-0461
9	Crystal, 6.947 MHz	Y-0462
10	Crystal, 7.047 MHz	Y-0463

PARTS LIST HØRER TIL
PÅ ~~DET~~ FORRIGE SIDE
100 KHz OSC.

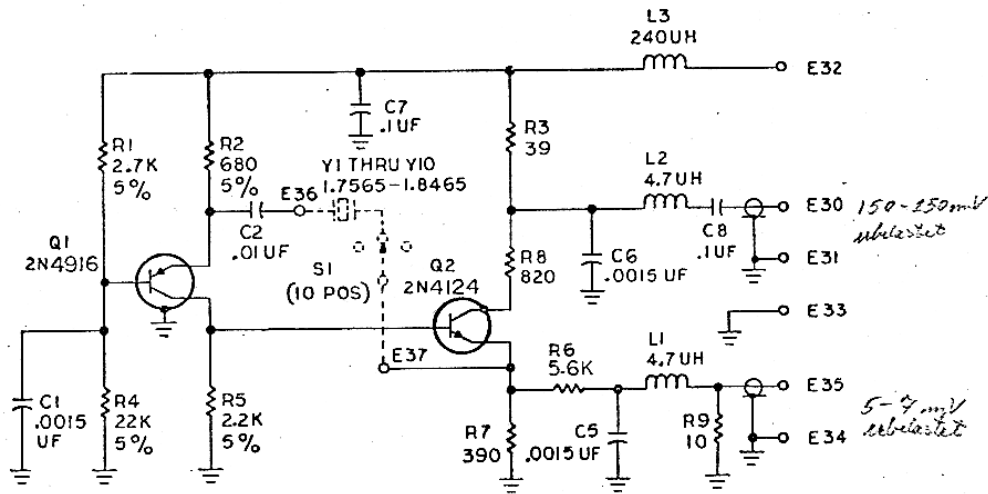

XTAL	FREQ MC	DIAL
Y1	1.7565	9
Y2	1.7665	8
Y3	1.7765	7
Y4	1.7865	6
Y5	1.7965	5
Y6	1.8065	4
Y7	1.8165	3
Y8	1.8265	2
Y9	1.8365	1
Y10	1.8465	0

NOTES:

- ALL RESISTORS ARE IN OHMS, 1/2W, 10%.

Figure 8.22 - 10 kHz Oscillator Schematic Diagram

8.23 1 Khz Oscillator Parts Location & 8.24 1 Khz Oscillator Schematic Diagram.

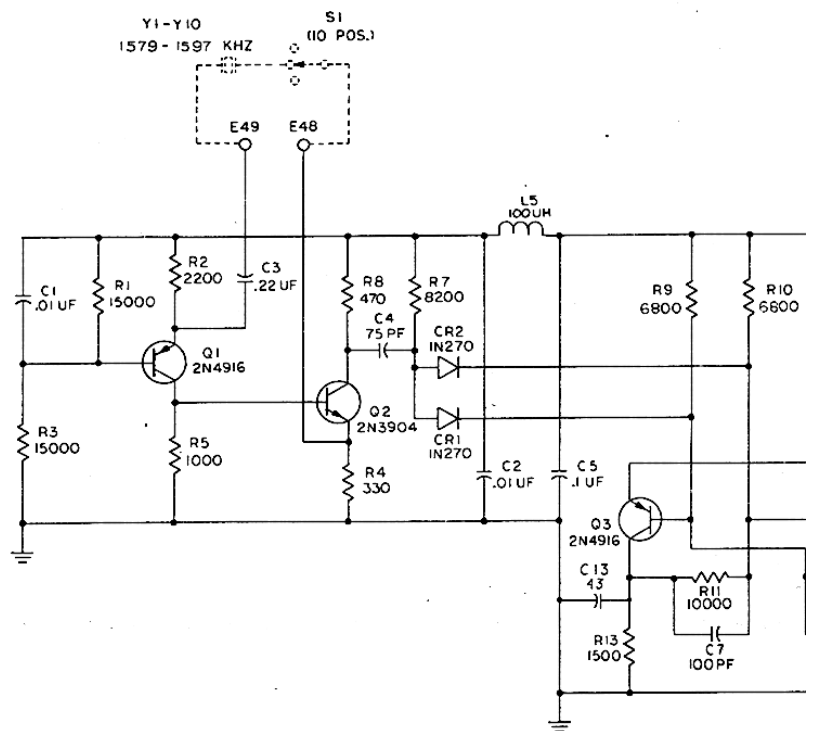
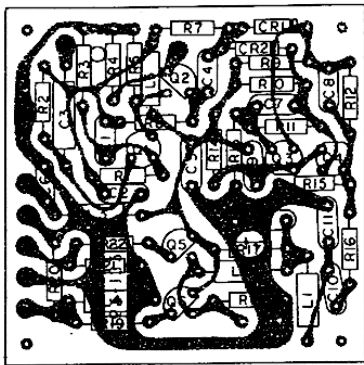

NOTES:

1. ALL RESISTORS ARE IN OHMS, $\frac{1}{4}$ W, 10%.

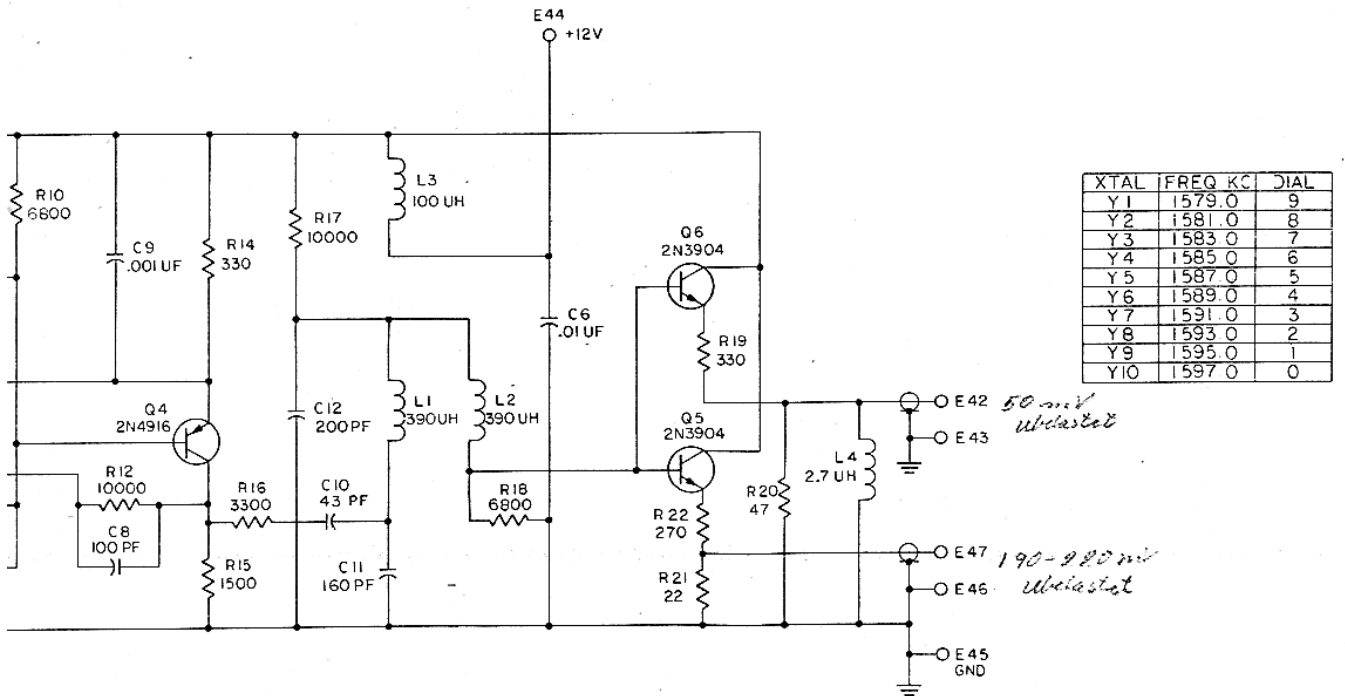

10%.

Figure 8.24 - 1 kHz Oscillator Schematic Diagram

8.25 ALC Parts Location & 8.26 ALC Schematic Diagram.

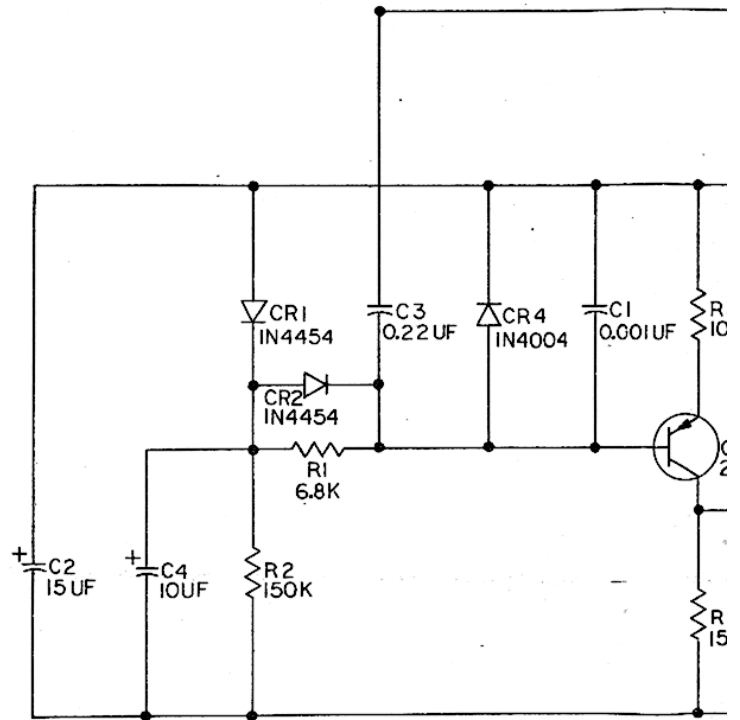
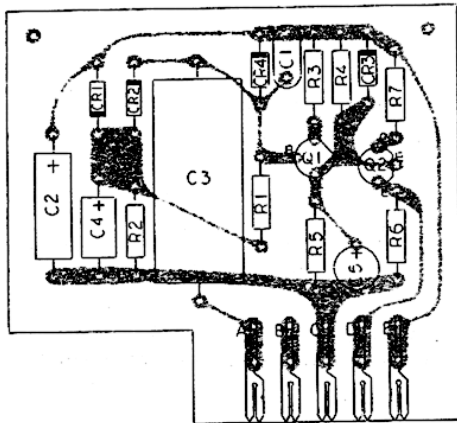

NOTES:
 1. ALL RESISTORS ARE IN OHMS, 1/4 WATT, 5%,
 UNLESS OTHERWISE SPECIFIED.

Figure 8.25 – ALC Parts Location

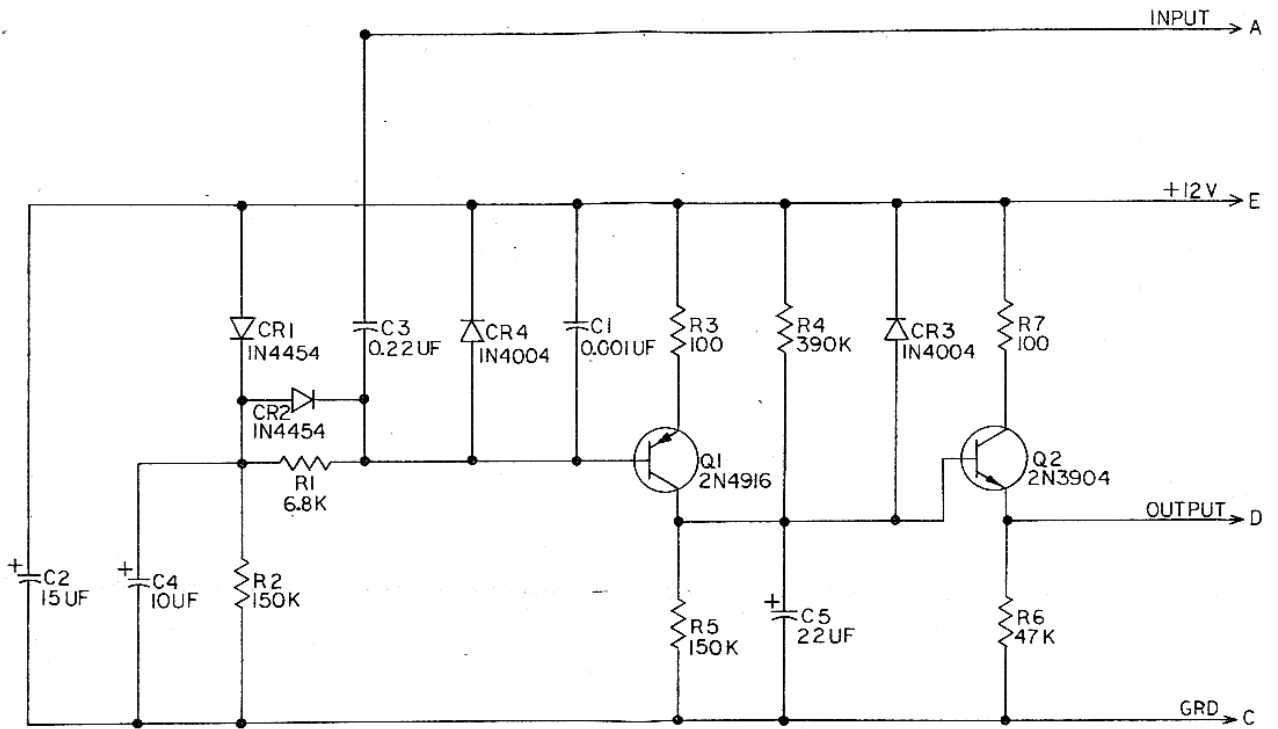

RESISTORS ARE IN OHMS, 1/4 WATT, 5%,
UNLESS OTHERWISE SPECIFIED.

Location

Figure 8.26 - ALC Schematic Diagram

8-27/8-28

8.27 ACC Parts Location & 8.28 ACC Schematic Diagram.

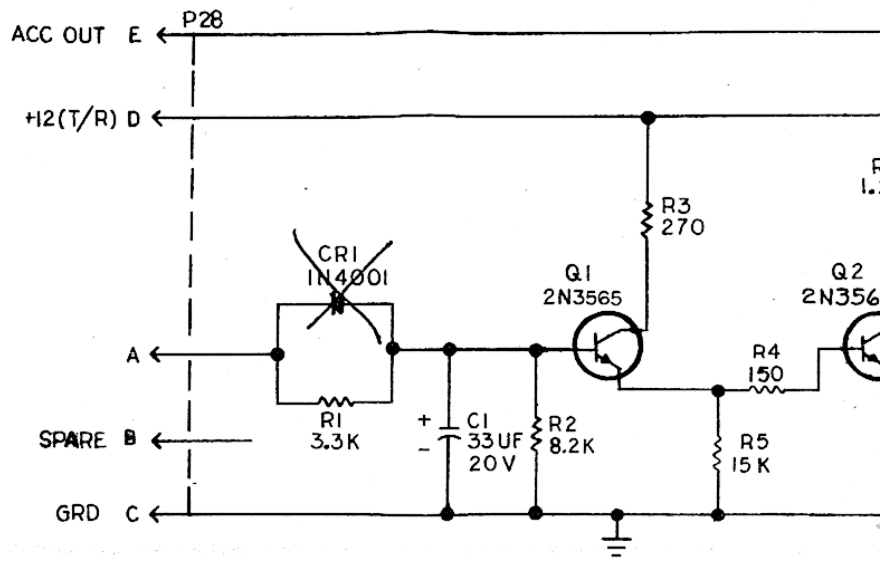
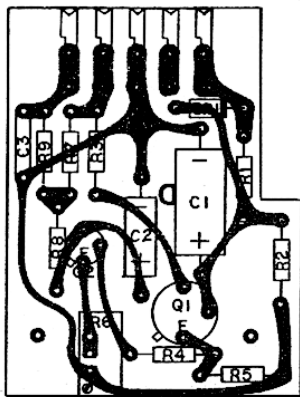

NOTE:

I. ALL RESISTORS ARE IN OHMS, 1/4W, 10%

Figure 8.27 – ACC Parts Location

Figure 8.28 – ACC Schematic

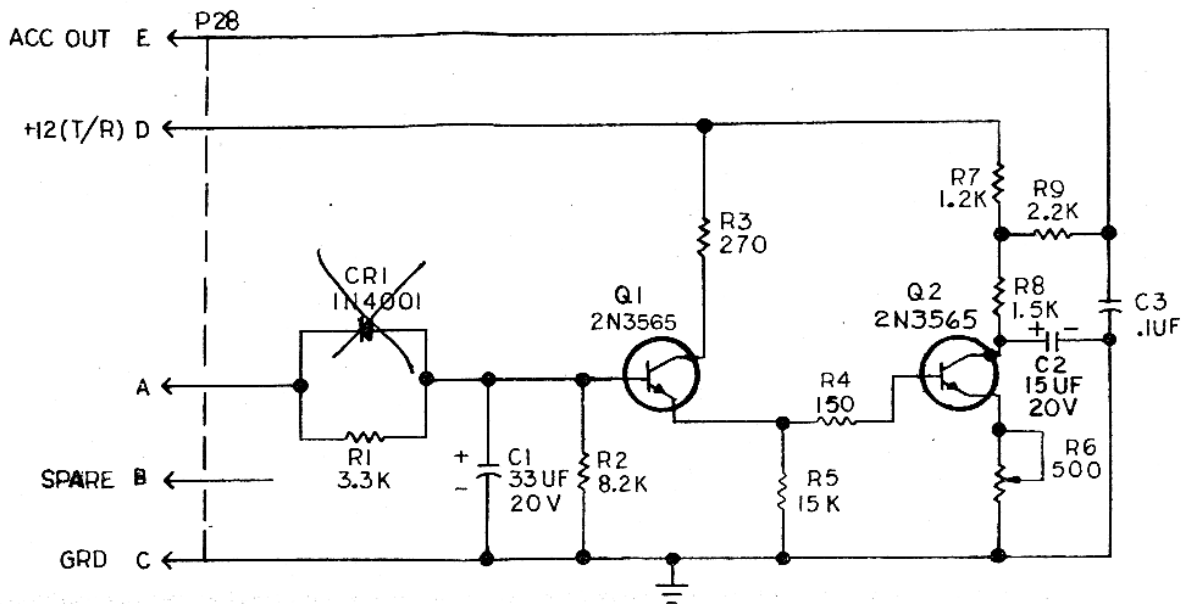

NOTE:

1. ALL RESISTORS ARE IN OHMS, 1/4W, 10%

Figure 8.28 – ACC Schematic Diagram

8.29 Audio Amplifier Parts Location & 8.30 Audio Amplifier Schematic Diagram.

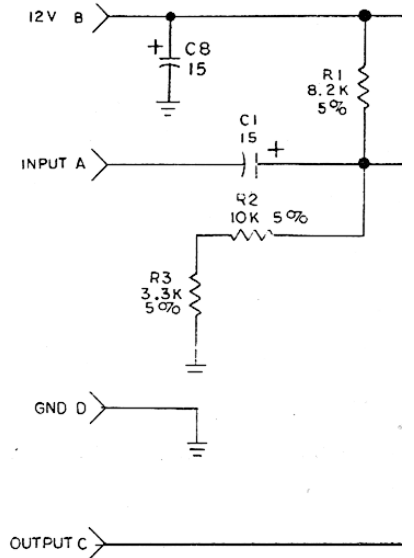
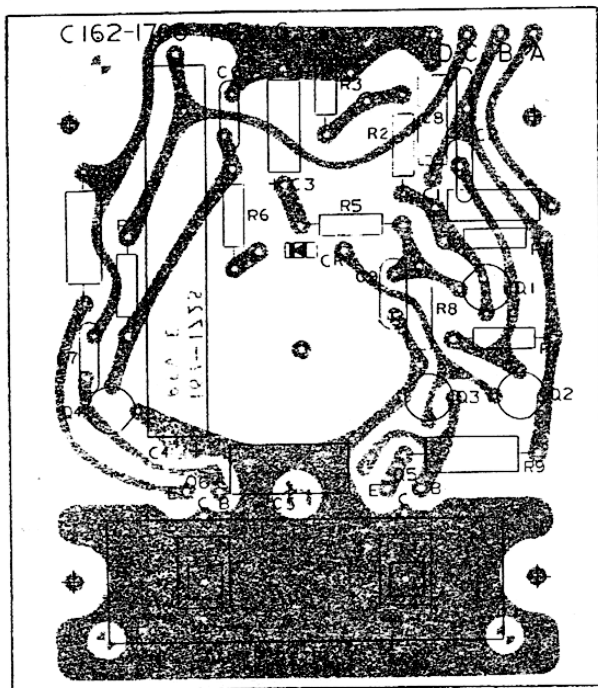

NOTES:
 ALL RESISTORS ARE IN OHMS , 1/
 ALL CAPACITORS ARE IN MICROFAR

Figure 8.29 – Audio Amplifier Parts Location

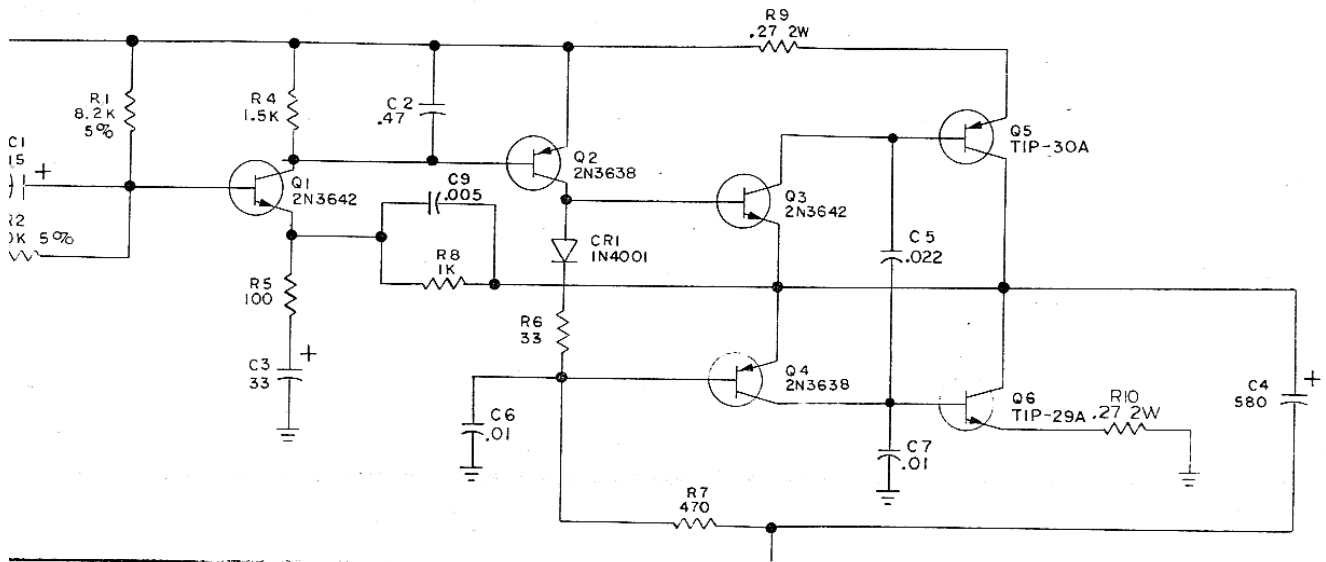

RESISTORS ARE IN OHMS, 1/2 W, 10% UNLESS OTHERWISE SPECIFIED.
CAPACITORS ARE IN MICROFARADS (UF).

Figure 8.30 — Audio Amplifier Schematic Diagram

8.31 Main Frame Schematic Diagram.



MAIN FRAME

CIRCUIT DIAGRAMS

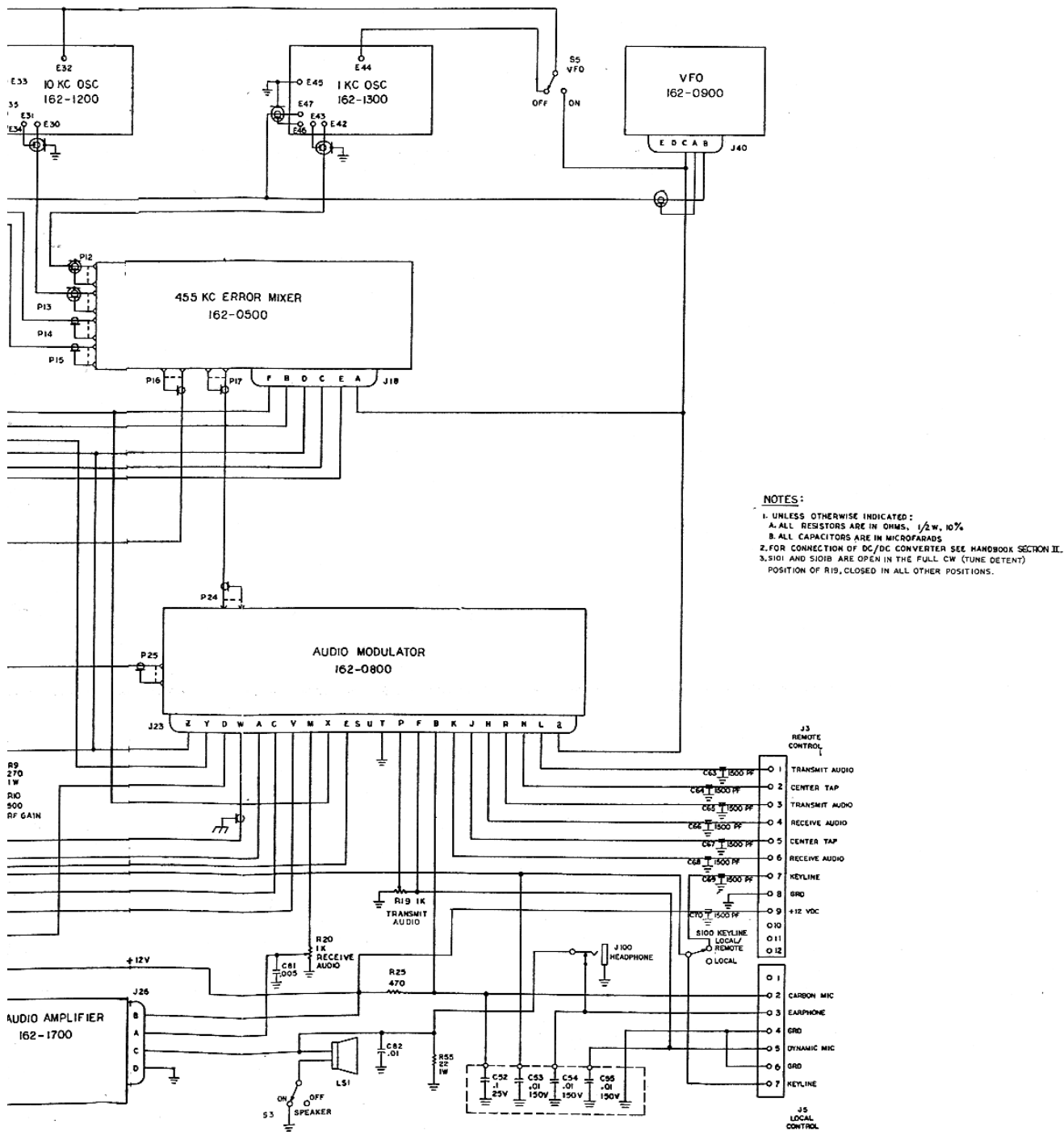

NOTES:
 1. UNLESS OTHERWISE INDICATED:
 A. ALL RESISTORS ARE IN OHMS, 1/2 W, 10%
 B. ALL CAPACITORS ARE IN MICROFARADS
 2. FOR CONNECTION OF DC/DC CONVERTER SEE HANDBOOK SECTION II.
 3. S101 AND S101B ARE OPEN IN THE FULL CW (TUNE DETENT) POSITION OF R19, CLOSED IN ALL OTHER POSITIONS.

Figure 8.31 – Main Frame Schematic Diagram

+12 VDC

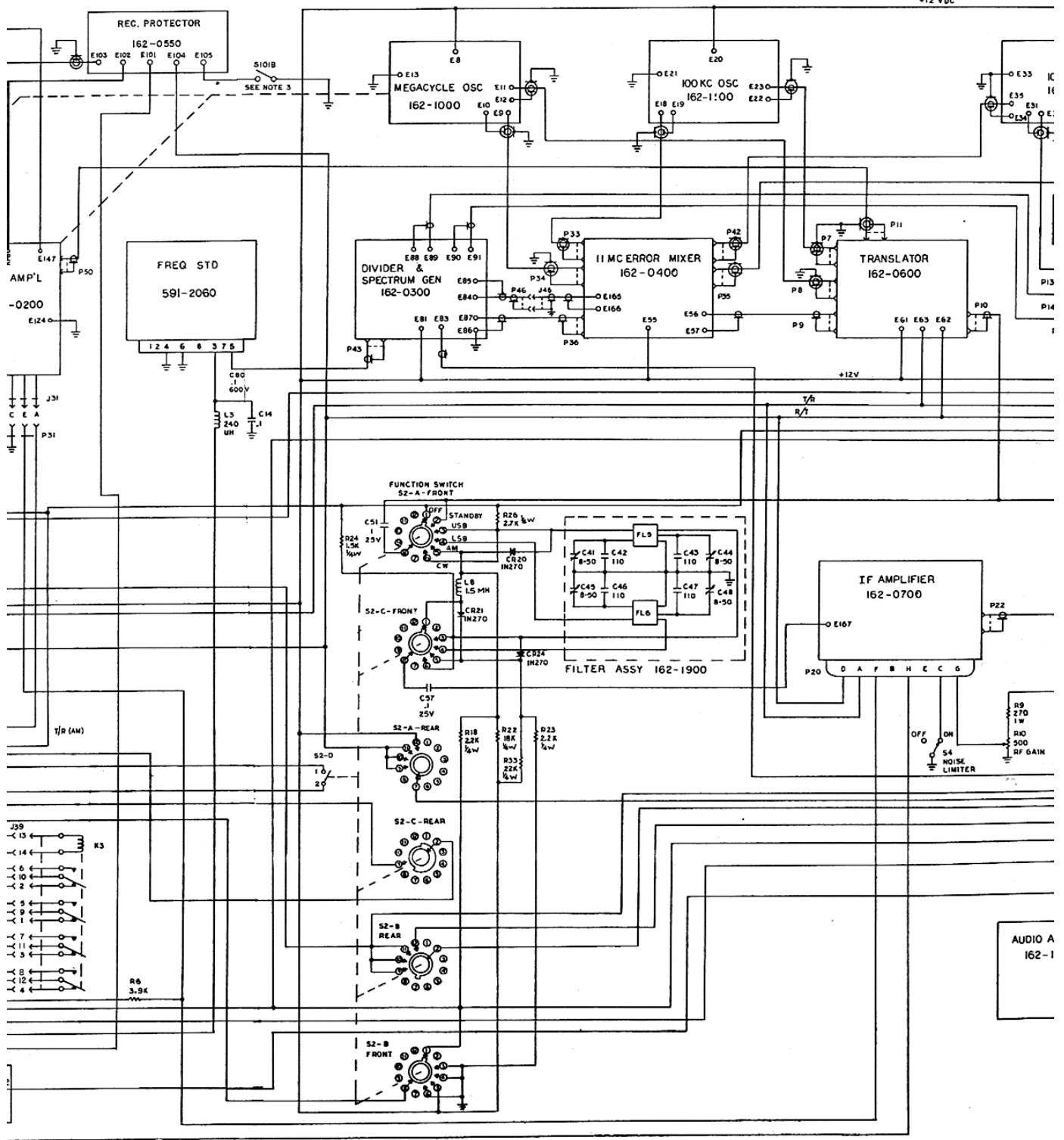

AUDIO A
162-1

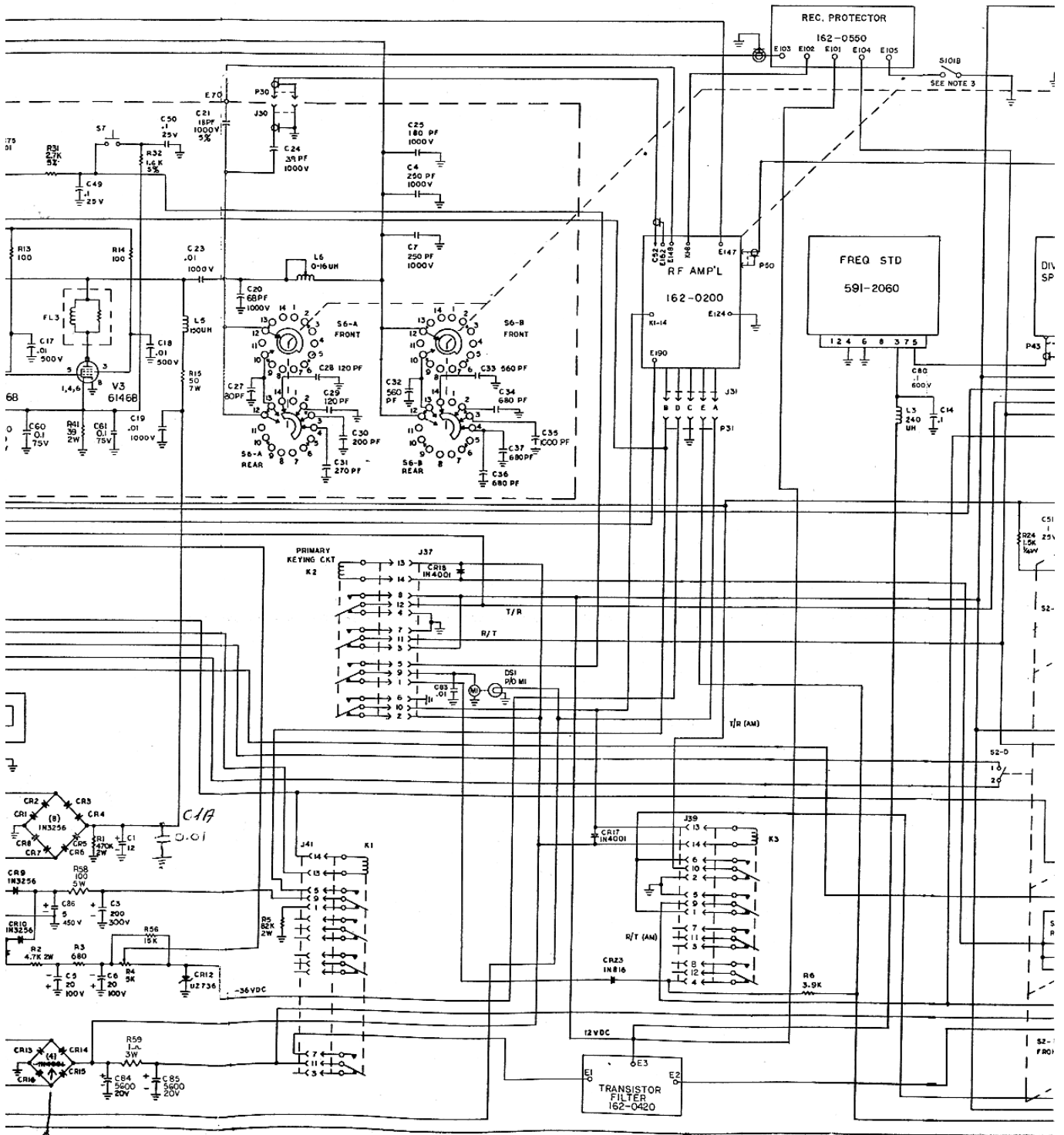

1N4140

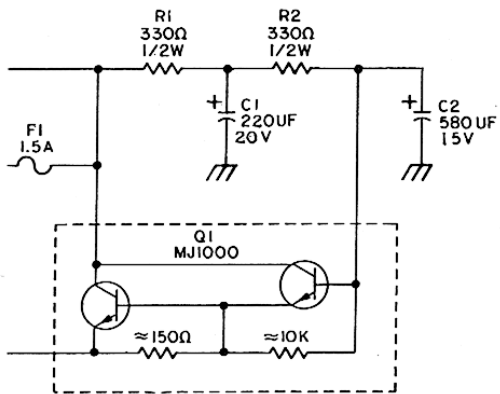

TRANSISTOR FILTER ASSEMBLY

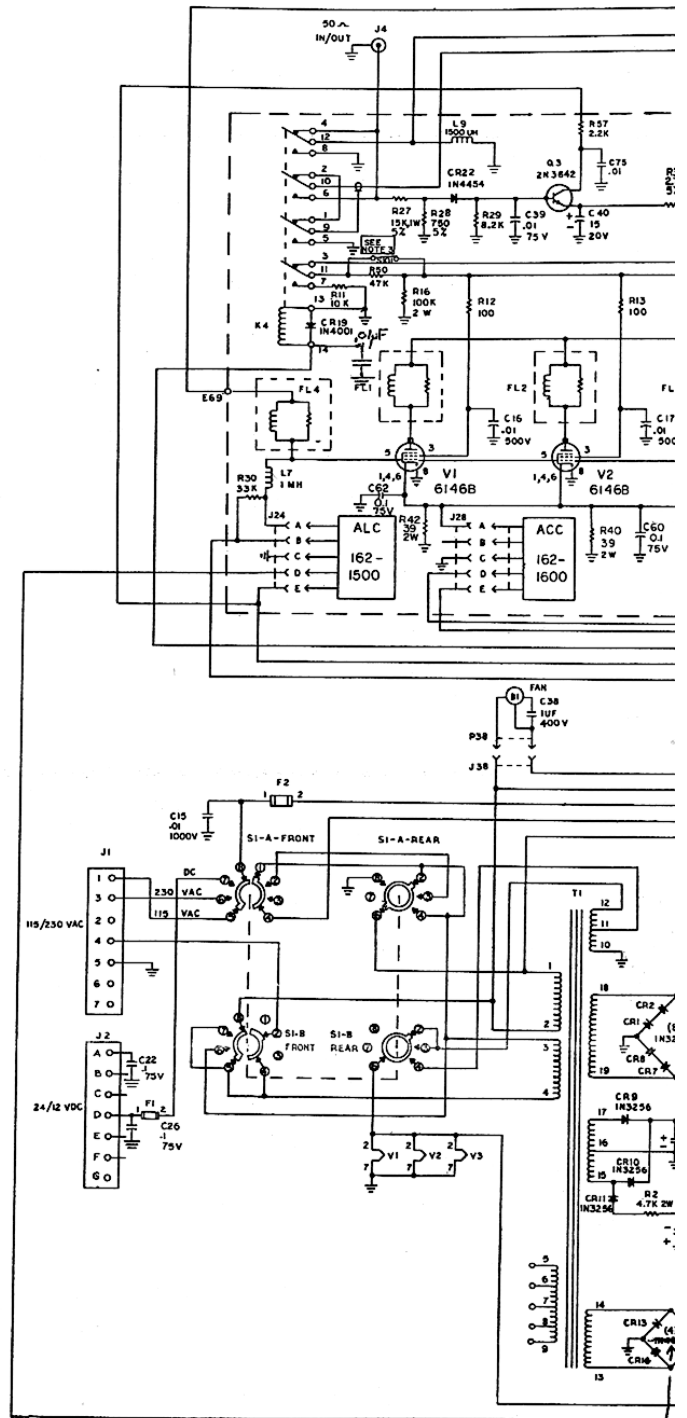

4stk. IN4

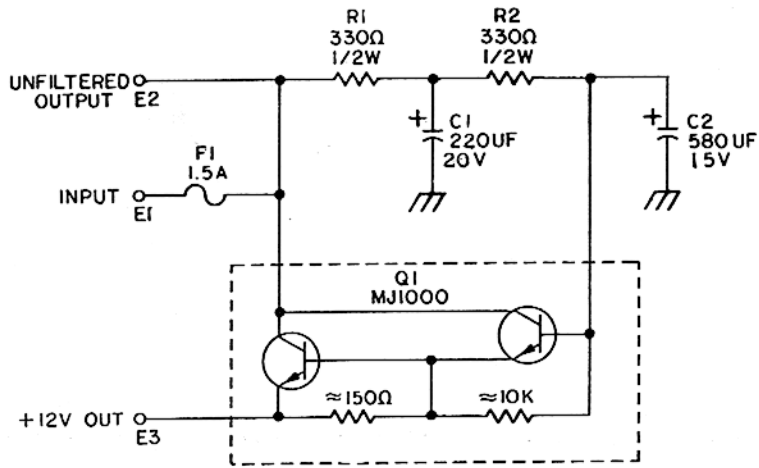

TRANSISTOR FILTER ASSEMBLY

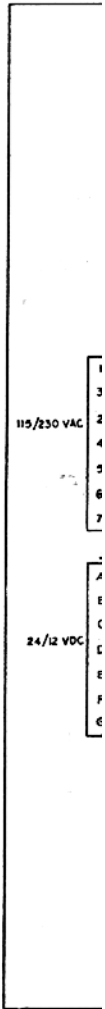

8.32 RF-303 13.5 V DC Power Module Schematic Diagram.



RF-303

CIRCUIT DIAGRAM

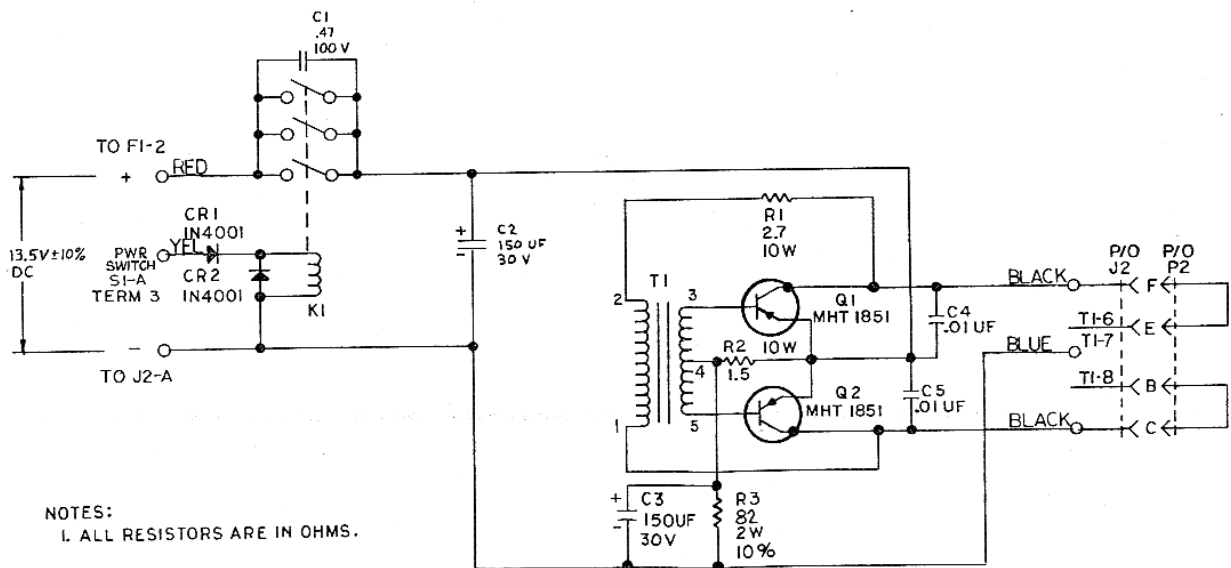

Figure 8.32 – RF-303, 13.5 VDC Power Module Schematic Diagram

8.33 RF-304 27.5 V DC Power Module Schematic Diagram.



RF-304

CIRCUIT DIAGRAMS

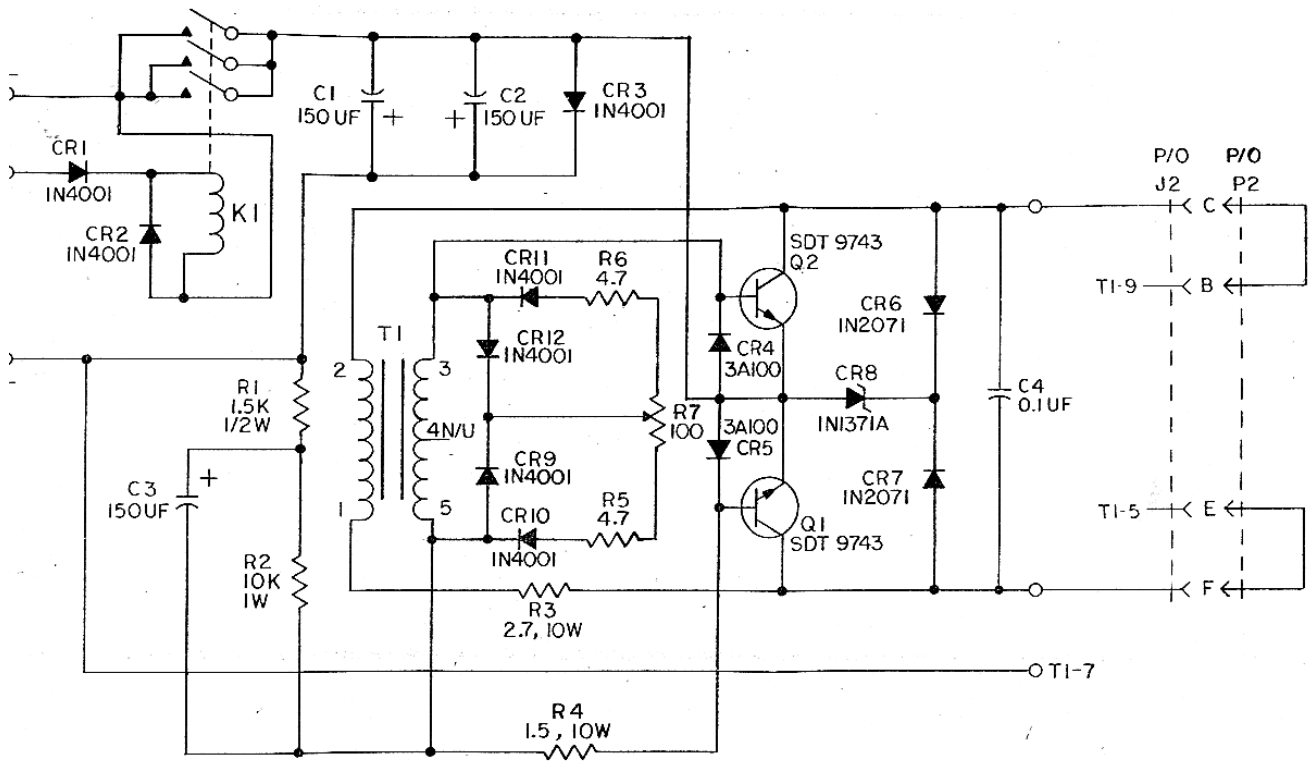

NOTES:

1. ALL RESISTORS ARE IN OHMS.

Figure 8.33 – RF-304, 27.5 VDC Power Module Schematic Diagram

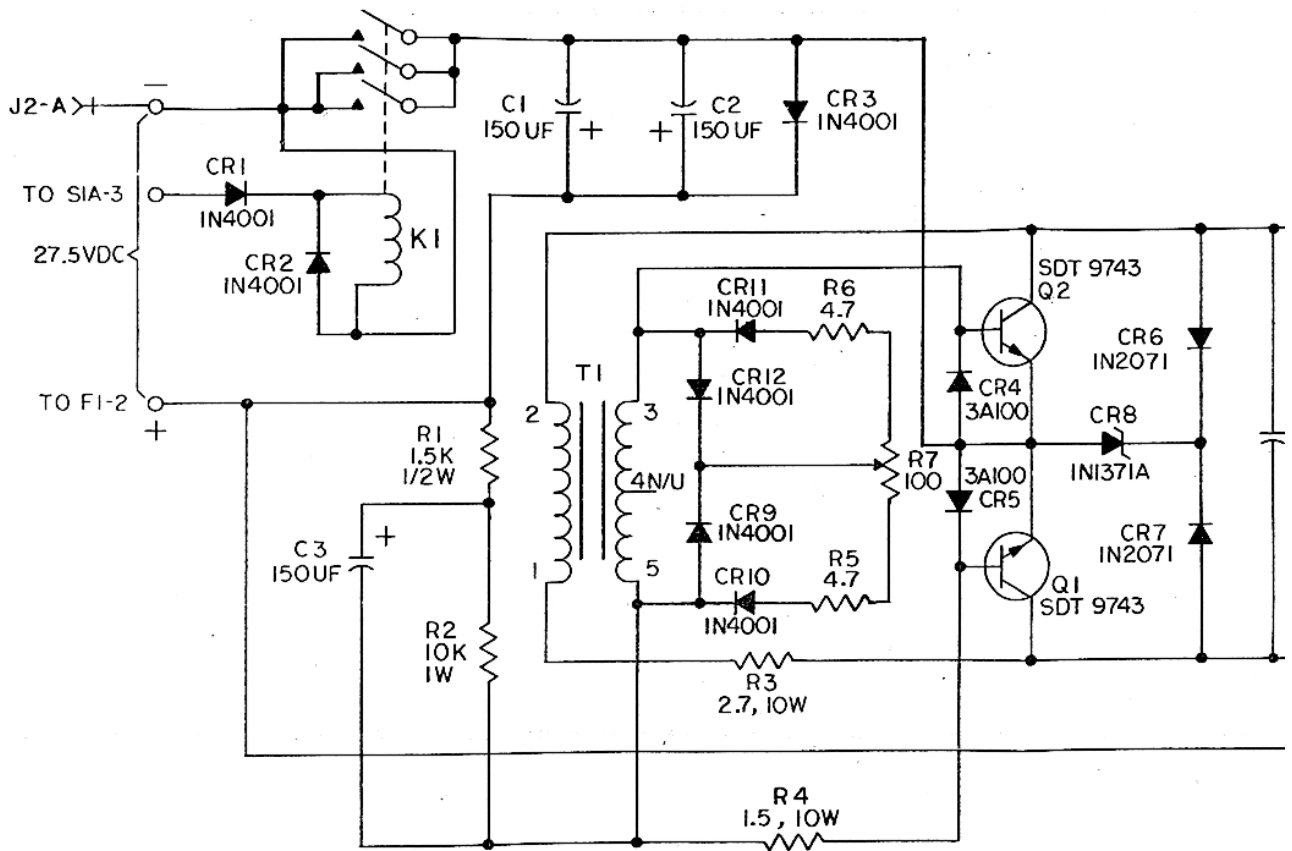

NOTES:
1. ALL RESISTORS ARE IN OHMS.

8.34 Receiver Protector Assembly Parts Location & 8.35 Receiver Protector Assembly Schematic Diagram.

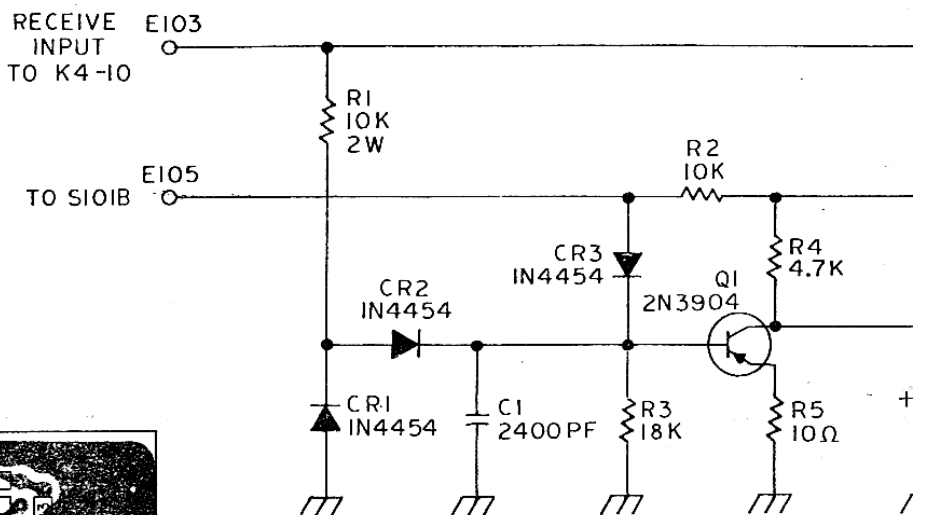
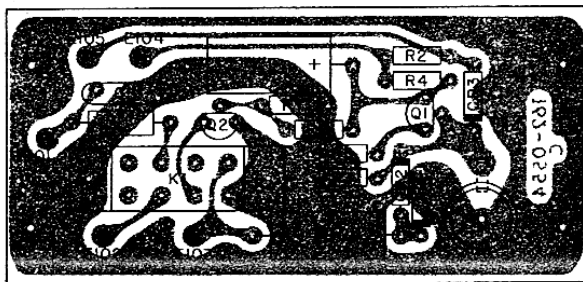

NOTES:
 I. RELAY SHOWN IN NORMAL (DE-ENERGIZED)

Figure 8.34 – Receiver Protector Assembly Parts Location

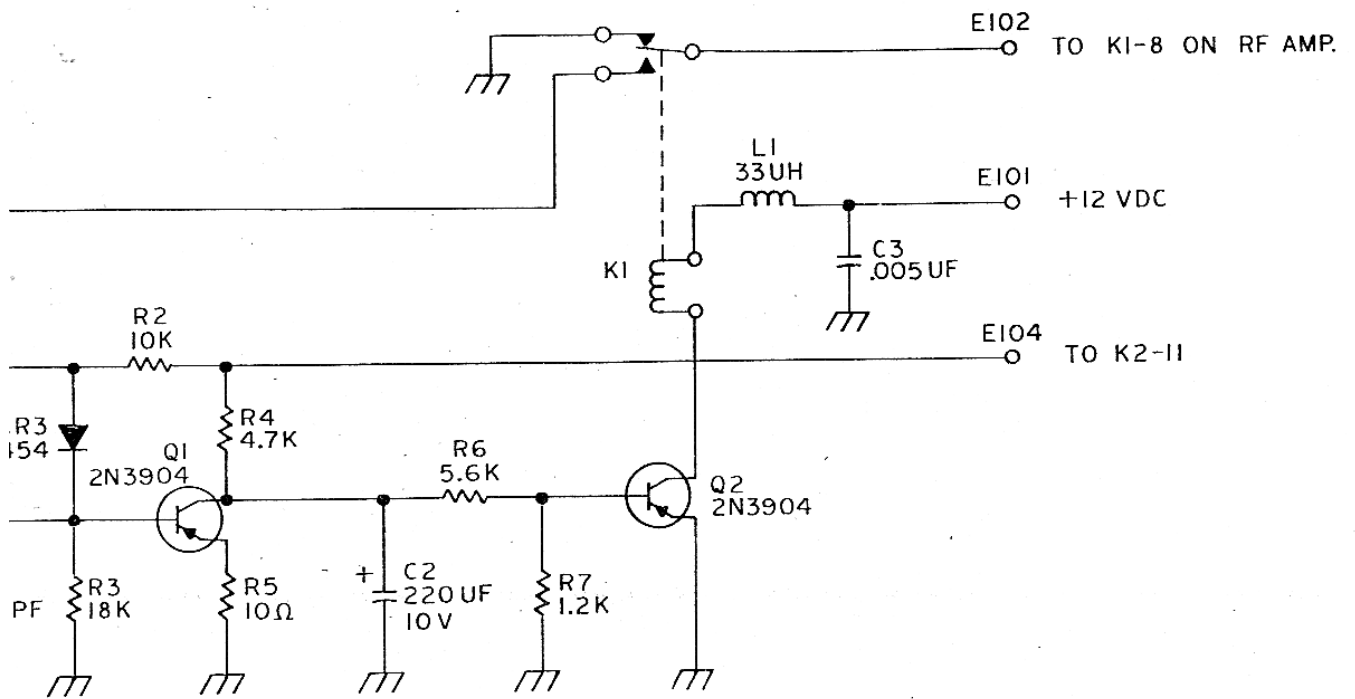

NORMAL (DE-ENERGIZED) POSITION.

Figure 8.35 — Receiver Protector Assembly Schematic Diagram

8.36 MK-0009 Microphone Schematic Diagram.



MK-0009

CIRCUIT DIAGRAMS

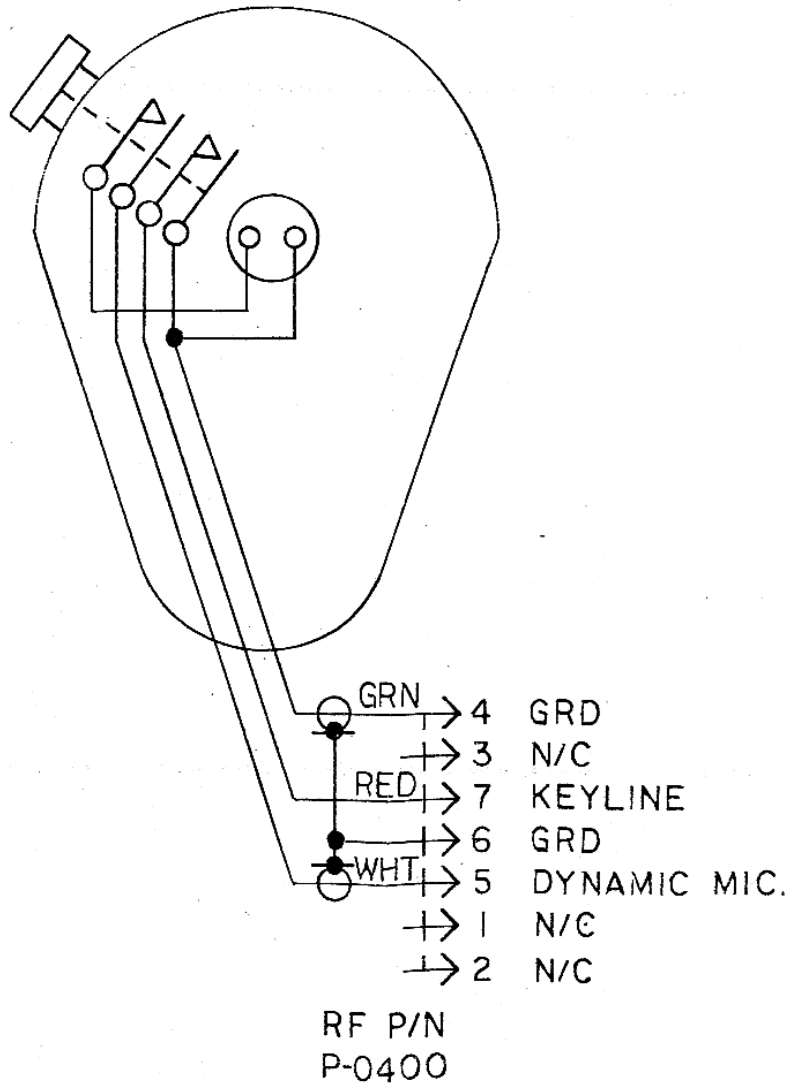

NOTE:
PIN 4 IS JUMPED TO PIN 6 IN THE RF-301.

Figure 8.36 – MK-0009 Microphone Schematic Diagram